



**MODULAR SERIES 2400/3000  
OFFICE FURNITURE**

---

# **MPN24**

---

## **PENINSULA TOP**

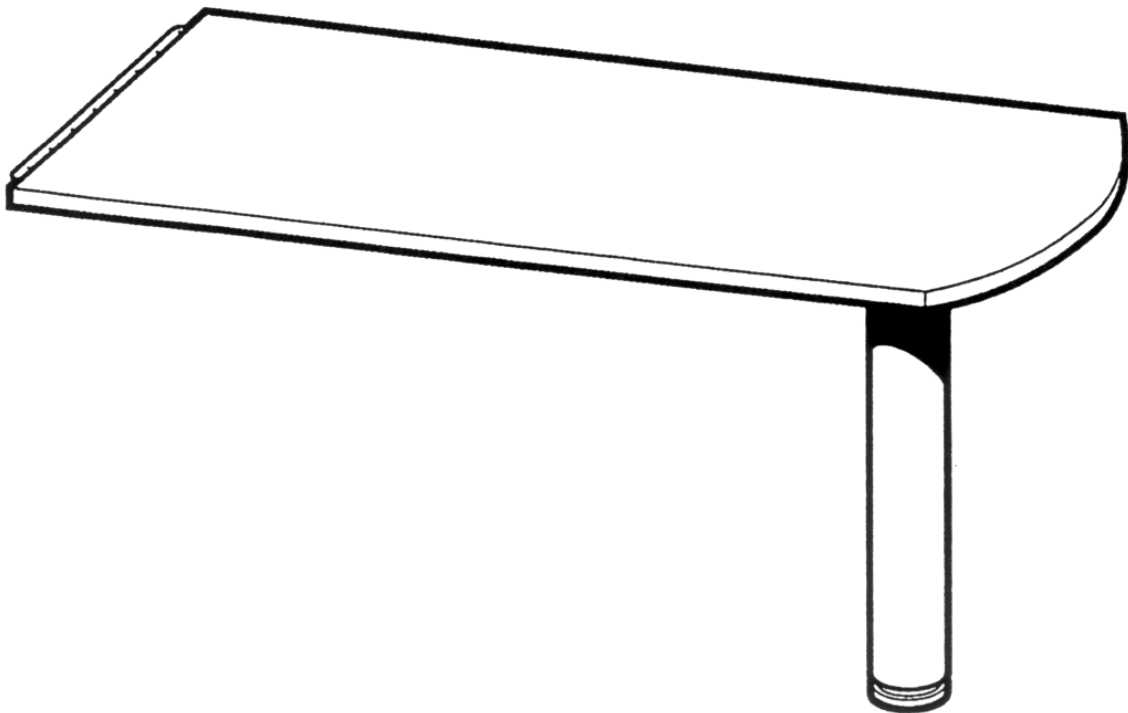

### **IMPORTANT!**

**Assembly may require the assistance of another person.**

**Before you begin assembly:**

**READ THE DIRECTIONS** all the way through one time. This will speed up the process and help you understand the sequence of steps.

**COUNT THE PARTS AND HARDWARE** before assembly. This ensures you have received all necessary parts before you begin.

**TOOLS:** You may need a Phillips head screwdriver, a medium slotted screwdriver or a plastic mallet. To protect your new furniture from damage during assembly, it is recommended to work on a carpeted surface.

In the event any parts are missing from this package, send your name, address, telephone number, and a description of the missing part(s) to: **PARTS, Box 1420, Missoula, MT 59806** or call: **1-800-769-5693** or **FAX 1-800-445-5281**.

**CAUTION:** On assemblies requiring glue, make sure the unit is assembled correctly before gluing. Once this unit is assembled with glue, the manufacturer will not be responsible for damaged parts. Keep a damp cloth or sponge handy to wipe off excess glue.

To care for this furniture, simply wipe with a cloth dampened with glass cleaner containing ammonia-D.

# PARTS DIAGRAM

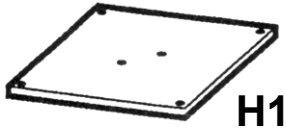

Leg Base	300770	1 ea.
----------	--------	-------



Support Leg	300770	1 ea.
-------------	--------	-------

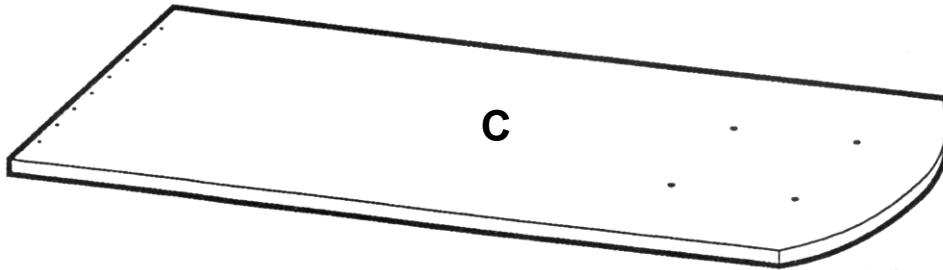

Top Panel	02330101	1 ea.
-----------	----------	-------



H3	Pedestal Leg Bolt	902505	2
----	-------------------	--------	---



H4	#8 x 3/4"	901208	20
----	-----------	--------	----

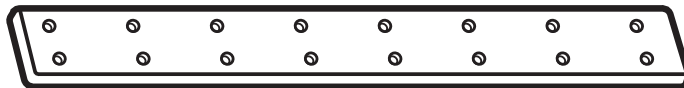

H5	18" Connector Plate	411270	1
----	---------------------	--------	---

**#1**

Attach the Leg Base (H1) to the Support Leg (H2) using two Pedestal Leg Bolts (H3) as shown.

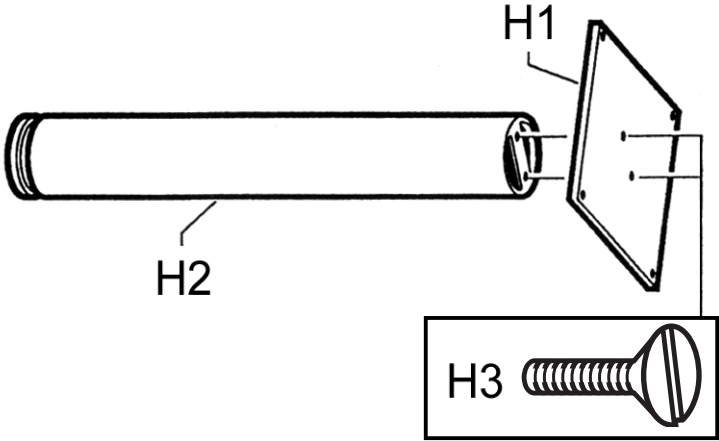

**#2**

Attach the Leg Base (H1) and the Support Leg (H2) assembly to the Top Panel (C) using four #8 x 3/4" Panhead Screws (H4) into the pre-drilled holes of the Top Panel.

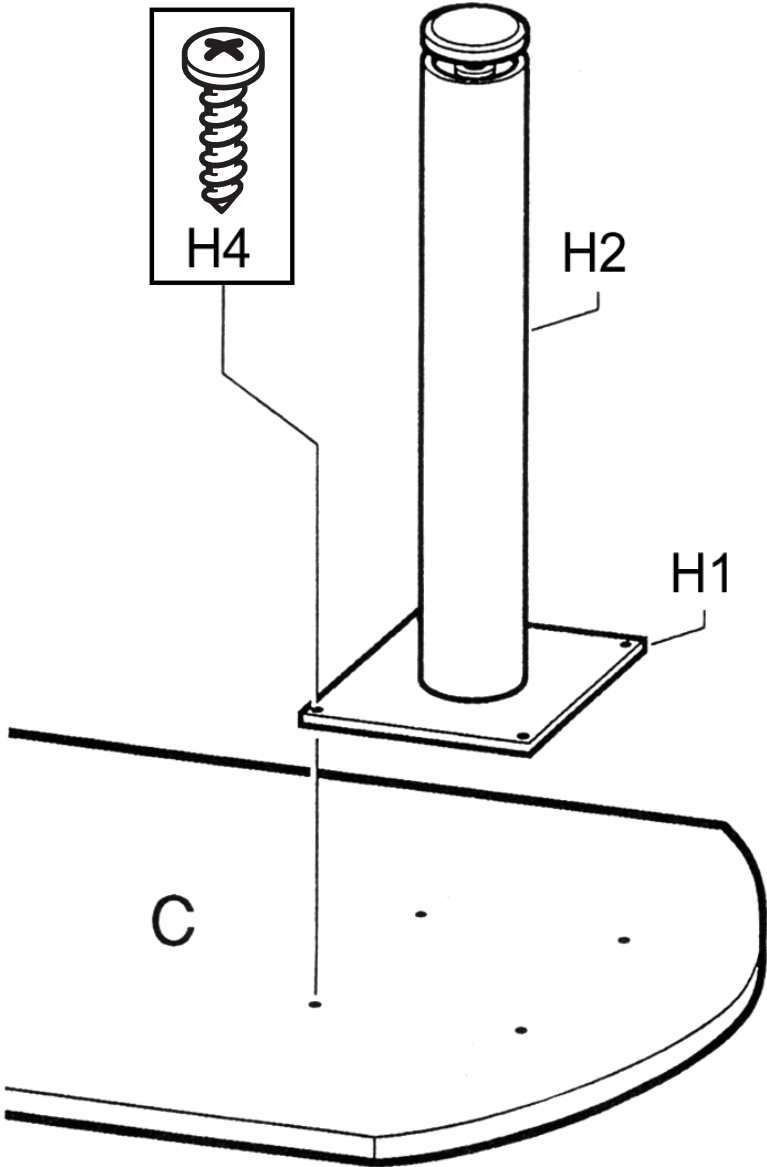

### #3

Select the location of the peninsula attachment. Attach a 18" Connector Plate (H5) to the underside of worksurface using eight #8 x 3/4" Panhead Screws.

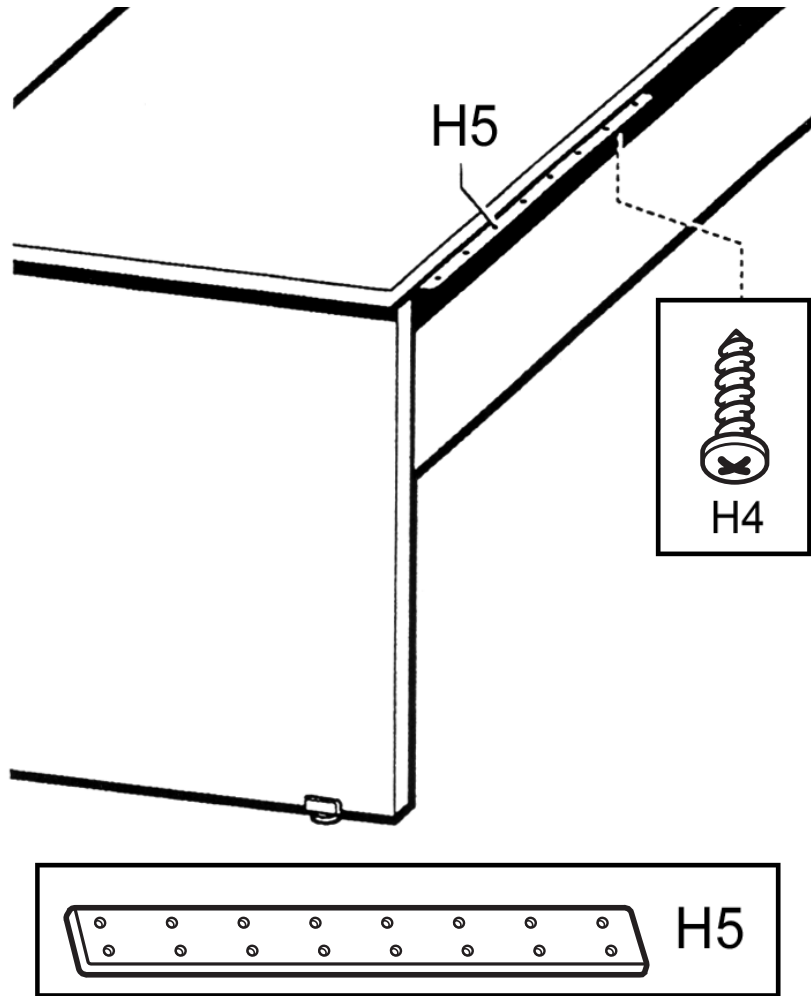

### #4

With the assistance of another person, turn the Peninsula unit upright. Position the edge of the Top Panel (C) over the Connector Plate (H4) with the holes aligned. Secure the Top Panel to the 18" Connector Plate using eight #8 x 3/4" Panhead Screws.

When the unit is in place, adjust the worksurface to level by turning the rotating bottom portion of the Support Leg (H2).

**Assembly is now complete.**

