

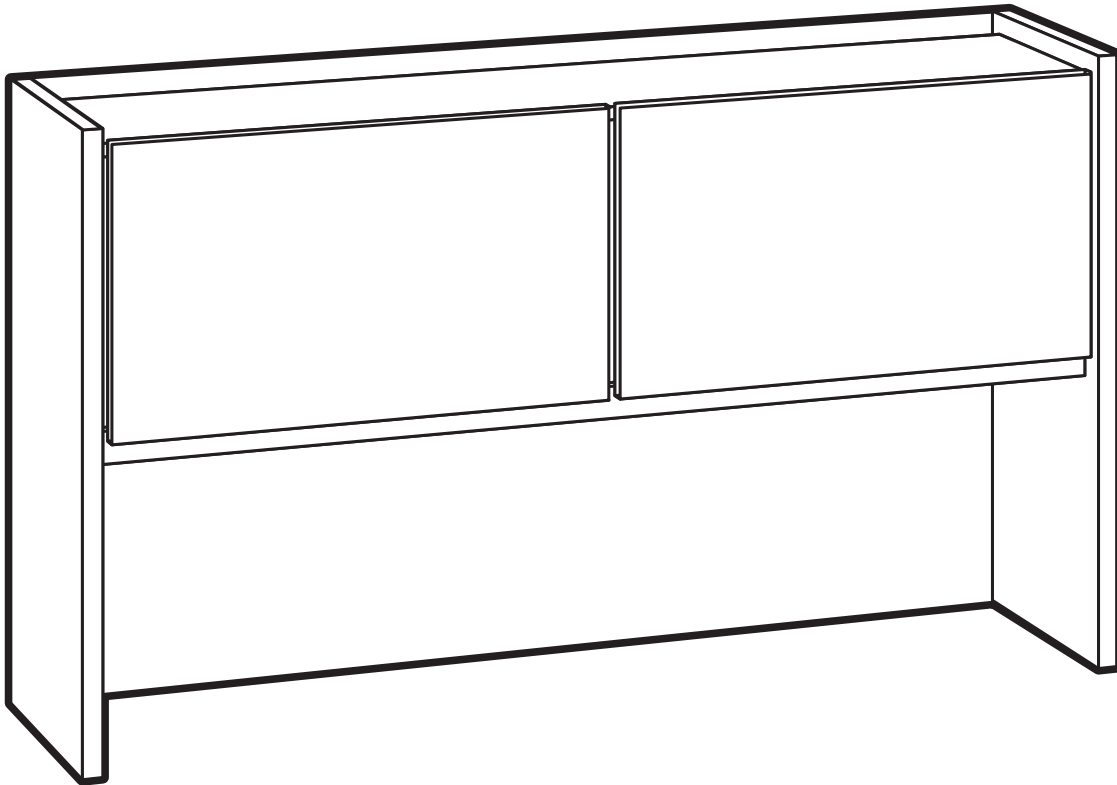

# MH60/MH72

## DESK HUTCH



### IMPORTANT!

Assembly may require the assistance of another person.

Before you begin assembly:

**READ THE DIRECTIONS** all the way through one time. This will speed up the process and help you understand the sequence of steps.

**COUNT THE PARTS AND HARDWARE** before assembly. This ensures you have received all necessary parts before you begin.

**TOOLS:** You may need a Phillips head screwdriver, a medium slotted screwdriver or a plastic mallet. To protect your new furniture from damage during assembly, it is recommended to work on a carpeted surface.

In the event any parts are missing from this package, send your name, address, telephone number, and a description of the missing part(s) to: PARTS, Box 1420, Missoula, MT 59806 or call: 1-800-769-5693 or FAX 1-800-445-5281.

**CAUTION:** On assemblies requiring glue, make sure the unit is assembled correctly before gluing. Once this unit is assembled with glue, the manufacturer will not be responsible for damaged parts. Keep a damp cloth or sponge handy to wipe off excess glue.

To care for this furniture, simply wipe with a cloth dampened with glass cleaner containing ammonia-D.

# PARTS DIAGRAM

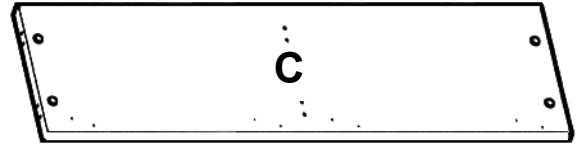
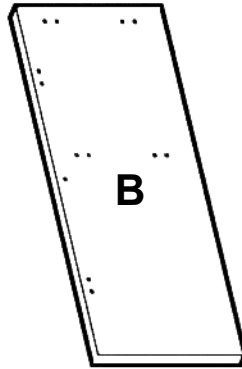
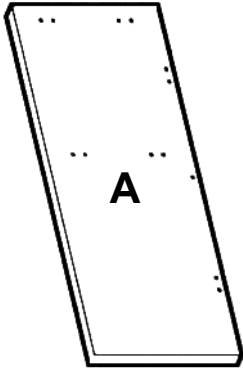

Top – MH60	02340141	1 ea.
Top – MH72	02340141	1 ea.

Left Side – MH60	02340141	1 ea.
Left Side – MH72	02340141	1 ea.

Right Side – MH60	02340141	1 ea.
Right Side – MH72	02340141	1 ea.

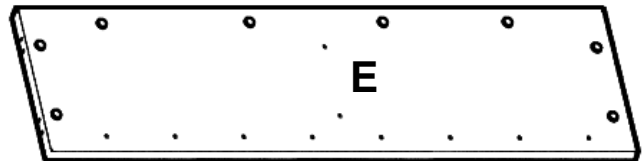
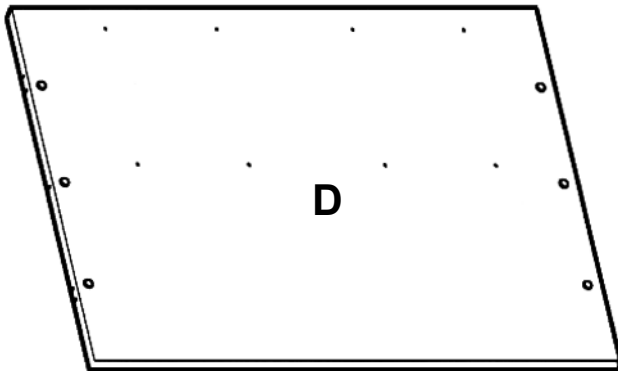

Shelf – MH60	02340127	1 ea.
Shelf – MH72	02340227	1 ea.

Back – MH60	02340152	1 ea.
Back – MH72	02340252	1 ea.

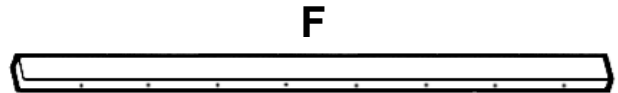

Facia Strip – MH60	02340186	1 ea.
Facia Strip – MH72	02340286	1 ea.

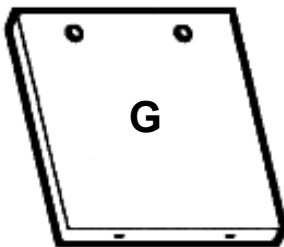

Divider	02340144	1 ea.
---------	----------	-------

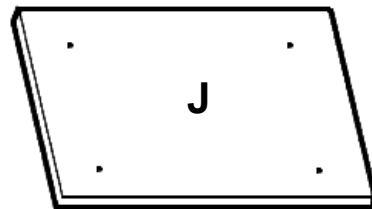

Doors – MH60	02340174	2 ea.
Doors – MH72	02340274	2 ea.

# HARDWARE



H1	Minifix Cam	909810	24 pr.
----	-------------	--------	--------



H2	Wood Dowel	195000	24 ea.
----	------------	--------	--------



H3	Minifix Bolt	909834	24 ea.
----	--------------	--------	--------



H4	Confirmat Screw	950100	2 ea.
----	-----------------	--------	-------



H5	Glue	295020	1 ea.
----	------	--------	-------

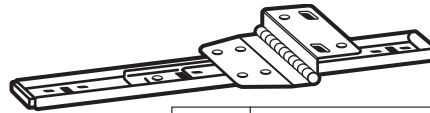

H6	Flipper Hinge Slide	490390	2 pr.
----	---------------------	--------	-------



H7	#8x5/8 Panhead Screw	988056	40 ea.
----	----------------------	--------	--------



H8	Door Bumper	298034	4 ea.
----	-------------	--------	-------



H9	Connector Bracket	401200	4 ea.
----	-------------------	--------	-------



H10	Attachment Tape	298530	2 ea.
-----	-----------------	--------	-------

### Using the Minifix System:

Insert the Minifix Cams into the appropriate holes with the arrow facing outwards as shown.

When screwing post into hole, **Do Not** over tighten. Screw post down until bottom face of post flange just touches board surface.

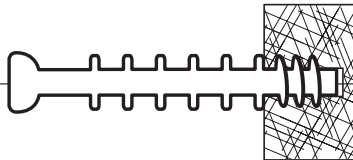
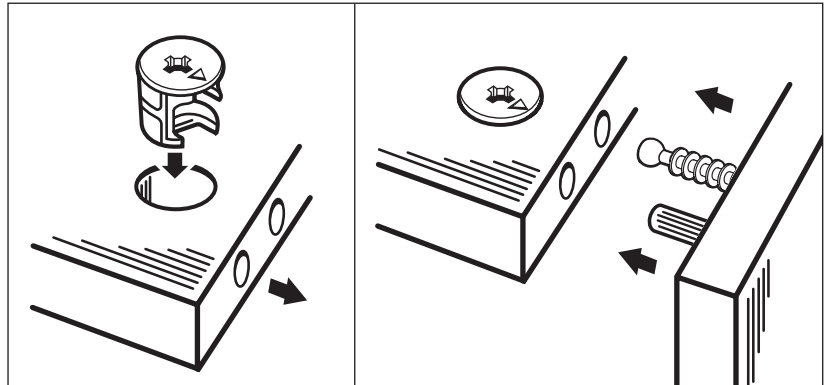

Using the #2 Phillips screwdriver, rotate the Cam Devices a half turn clockwise until snug.

To disassemble, turn the Cam Devices counter-clockwise and remove panels.

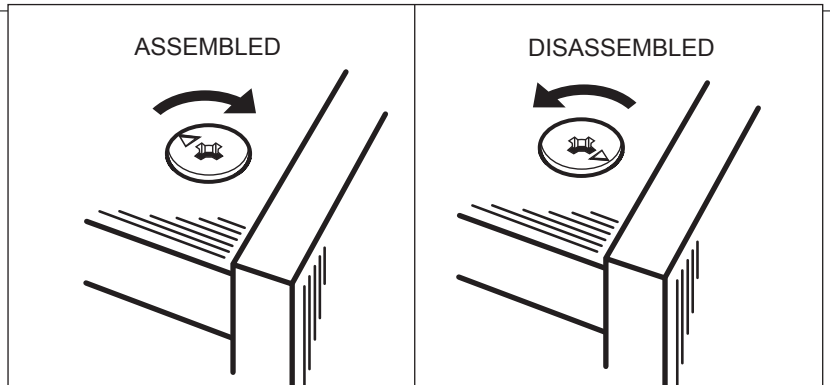

*The MH60 and MH72 are slightly different, but assemble in the same way. The MH60 is shown here.*

## #1

Place the Shelf (E) as shown on a clean, carpeted surface. Insert eight Minifix Cams (H1) into the Shelf (E) with the arrows of the cams facing out.

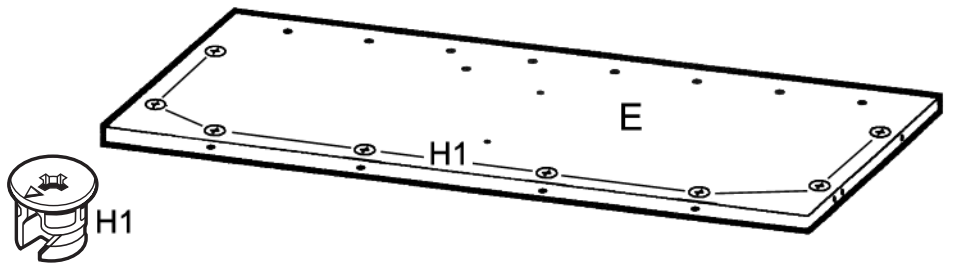

## #2

Insert eight Dowels (H2) into pre-drilled holes of Facia Strip (F). Apply a small amount of Glue (H5) onto the dowels of the Facia Strip (F). Position the Facia Strip (F) into the corresponding holes in the Shelf (E) and press firmly into place. Wipe away any excess glue with a damp cloth. Set aside to dry.

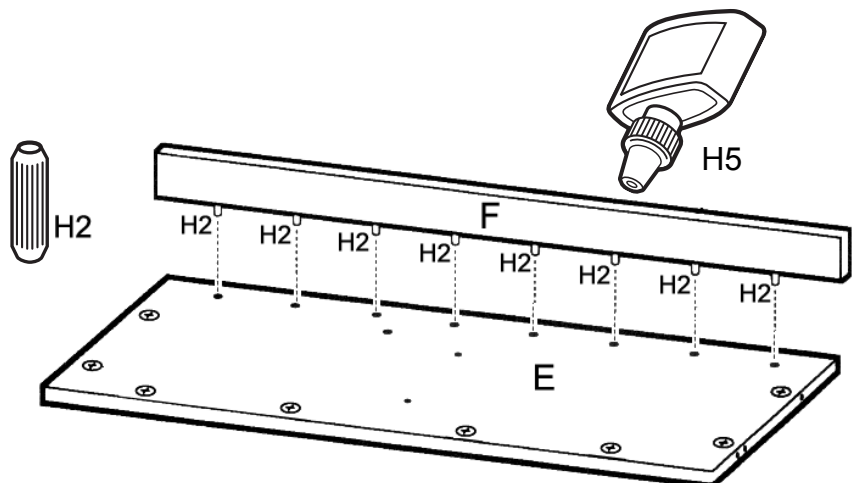

**NOTE:** Use ten Dowels (H2) for the MH72.

### #3

Place the Top (C) with the cam holes upright as shown. Insert eight Minifix Cams (H1) into the Top (C) with the arrows facing out.

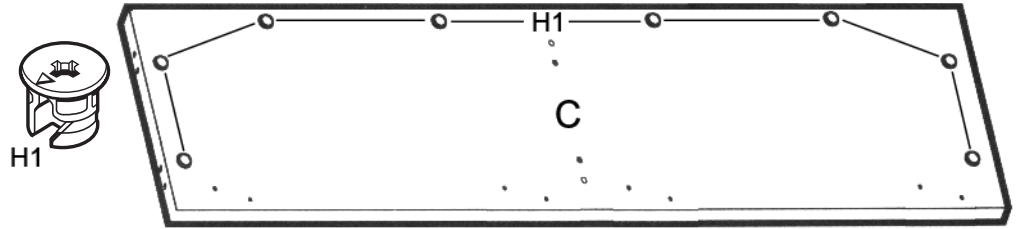

### #4

Screw two Minifix Bolts (H3) and insert two Dowels (H2) into the Top (C) where indicated.

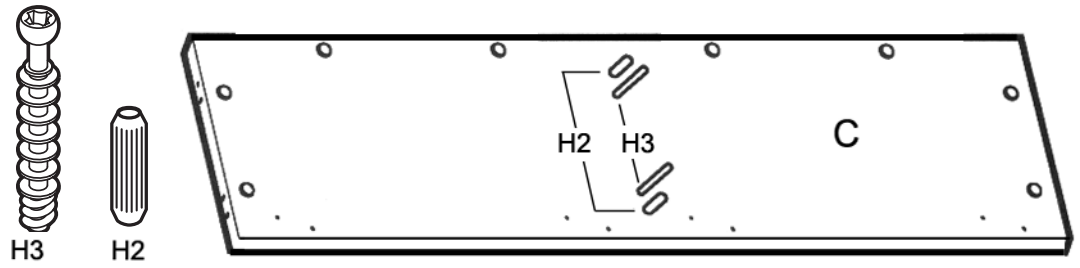

### #5

Place the Left Side (A) with the pre-drilled holes facing up. Screw seven Minifix Bolts (H3) and insert six Dowels (H2) into the Left Side (A) where indicated.

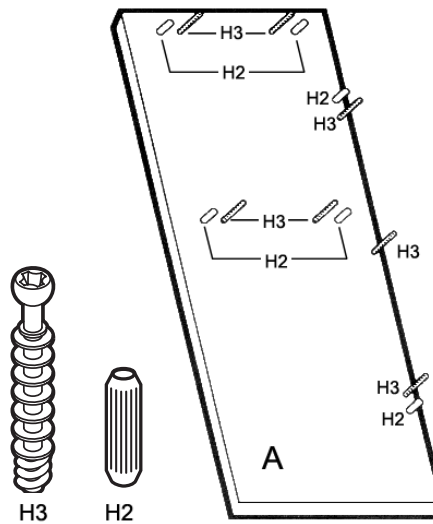

### #6

Place the Right Side (B) with the pre-drilled holes facing up. Screw seven Minifix Bolts (H3) and insert six Dowels (H2) into the Right Side (B) where indicated.

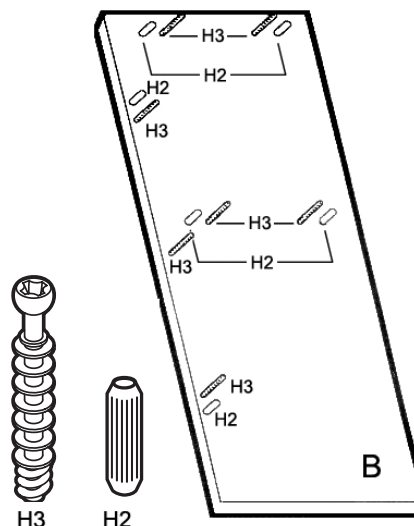

**#7**

Place the Back (D) as shown. Insert six Minifix Cams (H1) into the Back (D) with the arrows of the cams facing out.

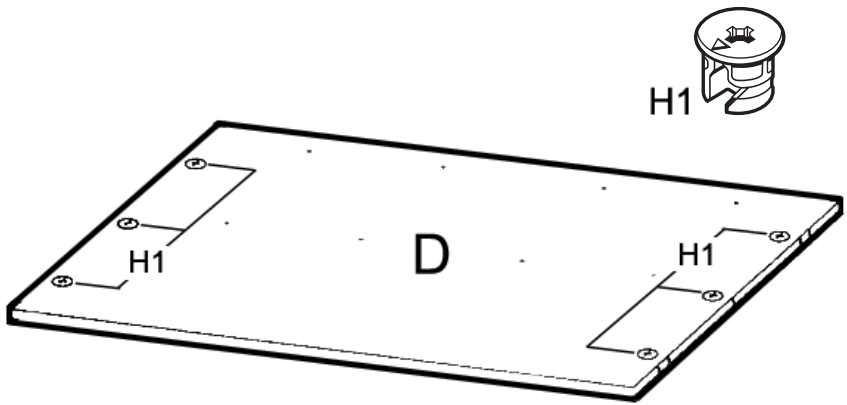

**#8**

Screw eight Minifix Bolts (H3) into the Back (D) where indicated.

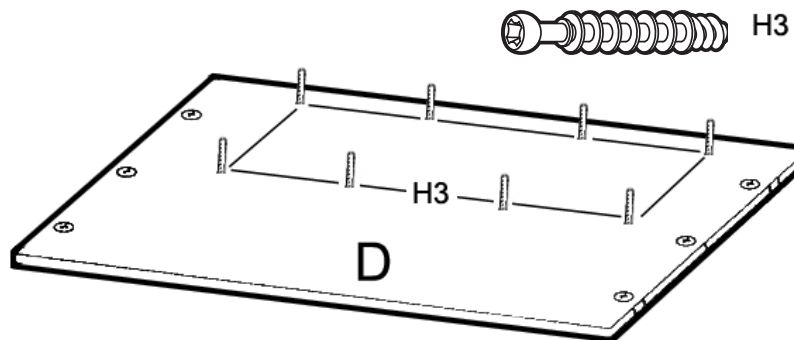

**#9**

Position the Top (C) onto the Back (D) and turn the arrows of the Minifix Cams (H1) clockwise to secure.

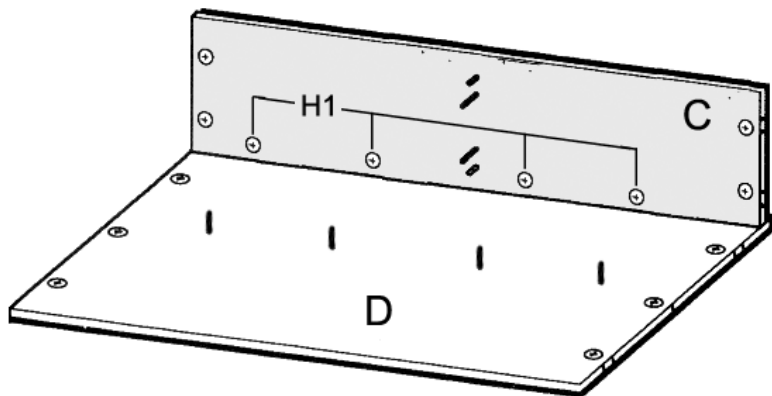

**#10**

Insert two Minifix Cams (H1) into the Divider (G) where indicated.



## #11

Position the Divider (G) onto the bolts and dowels of the Top (C) and turn the arrows of the Minifix Cams (H1) clockwise to secure.

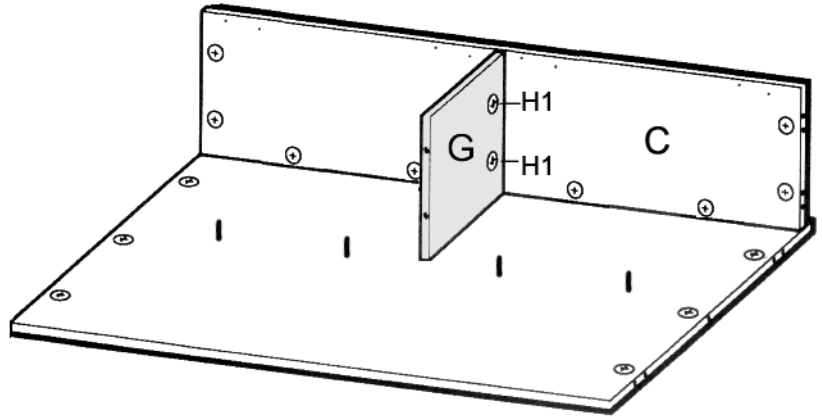

## #12

Position the Shelf (E) and Facia Strip (F) assembly onto the bolts of Back (D) as shown and turn the arrows of the Minifix Cams (H1) clockwise to secure.

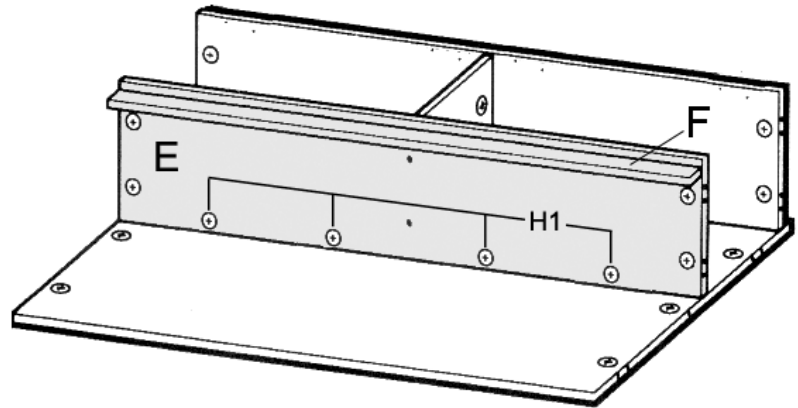

## #13

Secure the Divider (G) to the Shelf (E) using two Confirmat Screws (H4) as shown.

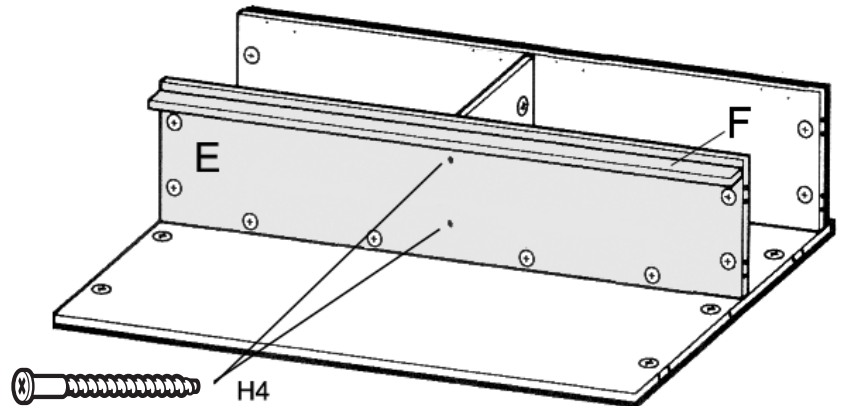

## #14

Position the Leftside (A) onto the unit and turn the arrows of the seven Minifix Cams (H1) clockwise to secure.

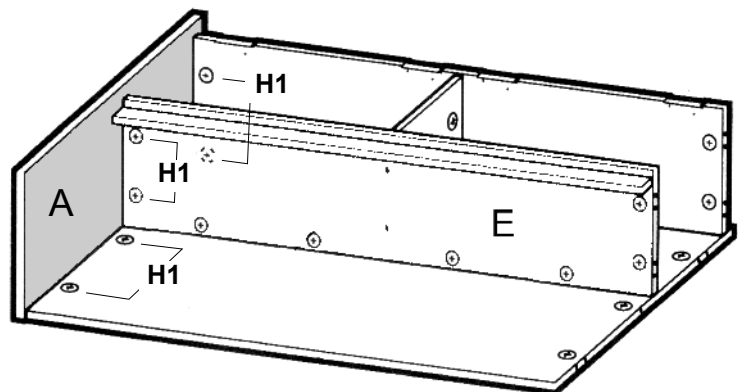

## #15

Position the Right Side (B) onto the unit and turn the arrows of the seven Minifix Cams (H1) clockwise to secure. Stand the unit upright.

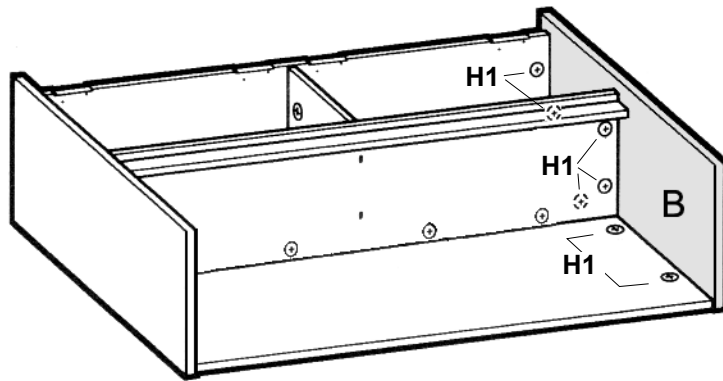

## #16

Attach two Flipper Hinge Slides (H6) to each Door (J) using 5/8" Panhead Screws (H7) through the indicated slots into the pre-drilled holes. NOTE: The screws should be installed into the center of each slot as shown.

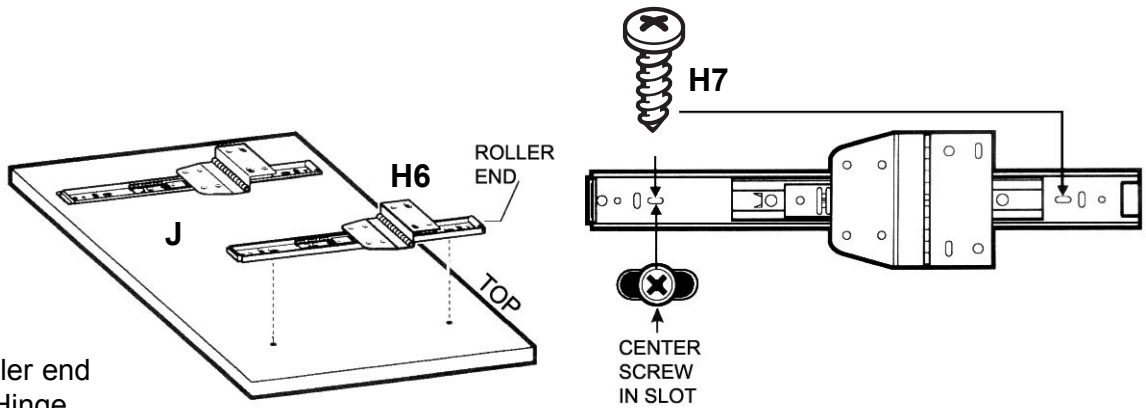

**NOTE:** The roller end of the Flipper Hinge Slide should be at the top edge of the Door.

## #17

Remove the backings from the Door Bumpers (H8) and stick to each bottom corner of the Doors about 1/2" from the edges as shown.

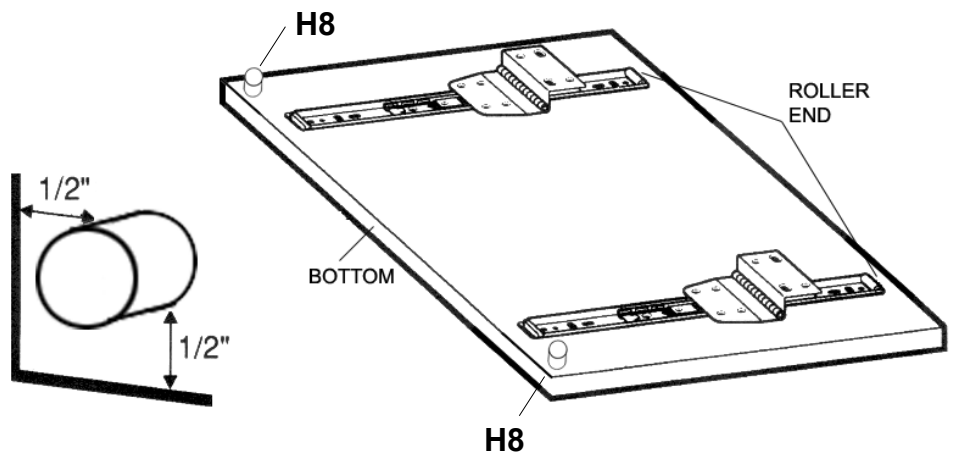



## #18

**NOTE:** Slide Doors toward back before installing screws.

Attach the Doors using 5/8" Panhead Screws (H7) through the slotted holes of the Flipper Hinge Slides into the pre-drilled holes in the underside of the Top (C).

**NOTE:** Install the screws into the center of the slotted hole.

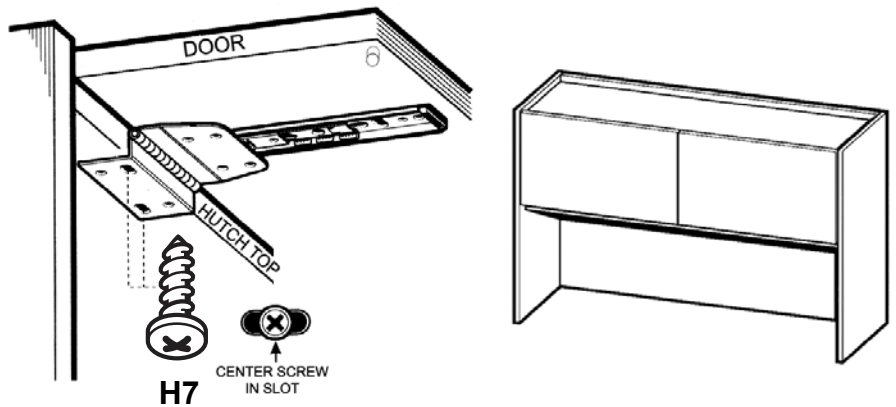

## #19

Check the Doors for side-to-side alignment. There should be approximately 1/8" space between each door and each side, and between both doors. If adjustment is necessary, slightly loosen screws, reposition the doors and retighten the screws.

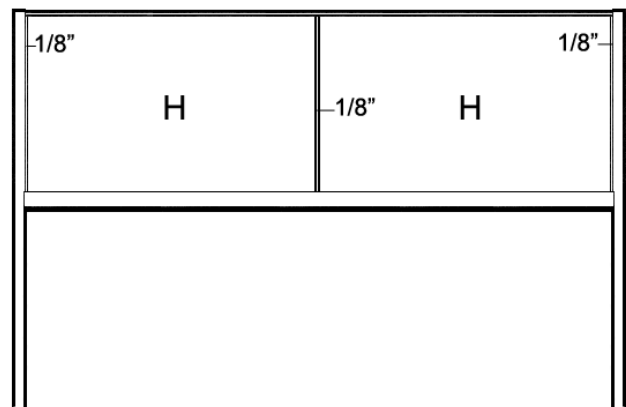

## #20

### IMPORTANT!

When the Doors are correctly aligned, secure Hinge in place with **four additional** 5/8" Panhead Screws in the indicated holes.

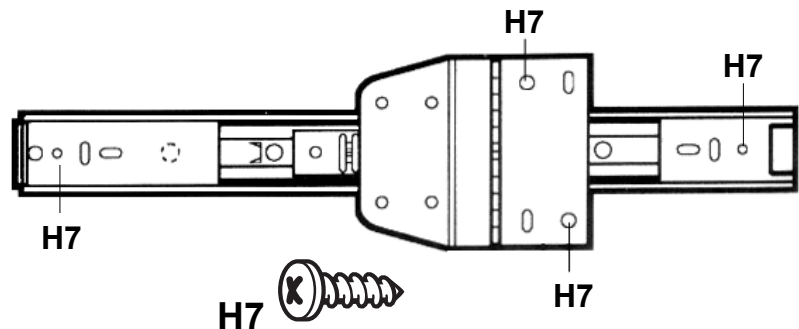

## #21

**Your Desk Hutch is now completely assembled and ready for use.**

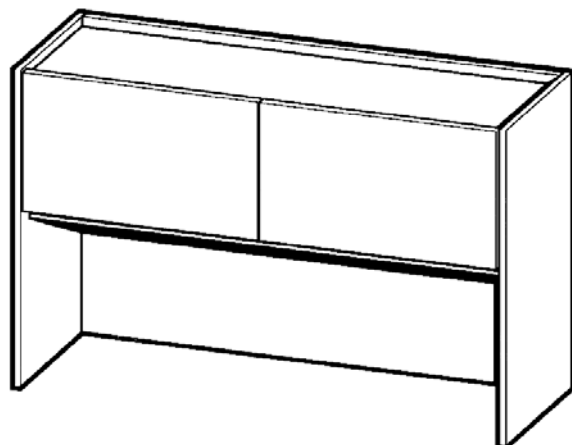

## ATTACHING THE HUTCH TO A DESK UNIT

The Hutch must be carefully centered on the desk unit as shown.

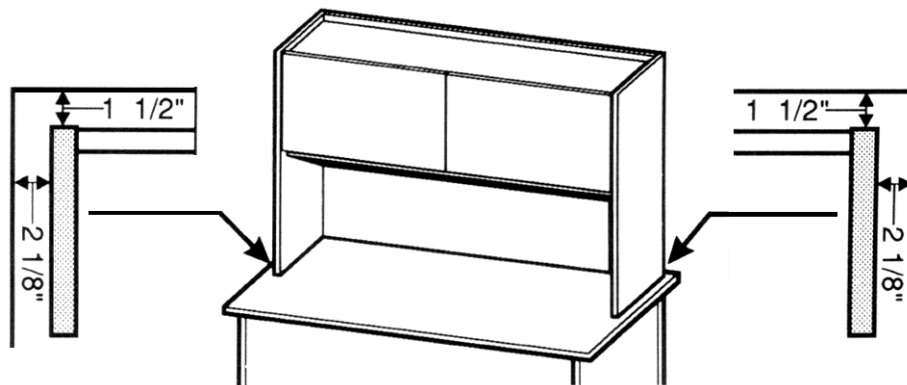

### CONNECTOR BRACKET METHOD

- A.** Carefully position the hutch onto the desktop as described in hutch location instructions (above).
- B.** With the hutch and desk aligned, position two Connector Brackets (H9) on each Side Panel (A & B) in the indicated locations. Mark the locations of the pilot holes with a pencil.

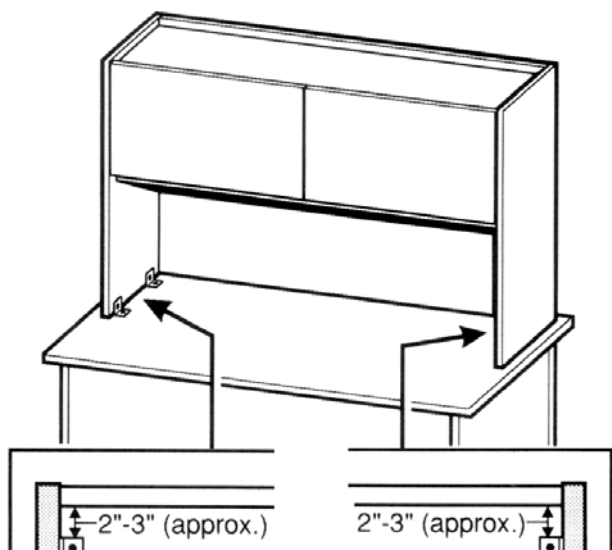

- C.** Using an electric drill and a 1/8" bit, drill the pilot holes 1/2" deep.

**NOTE:** Be careful not to drill all the way through the side panels.

- D.** Secure the hutch sides to the desktop using the 5/8" Panhead Screws (H7) through the four Connector Brackets.

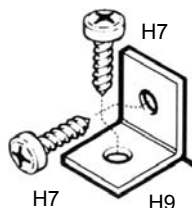

### TAPE METHOD

- A.** Carefully position the hutch onto the desktop as described in hutch location instructions (above).

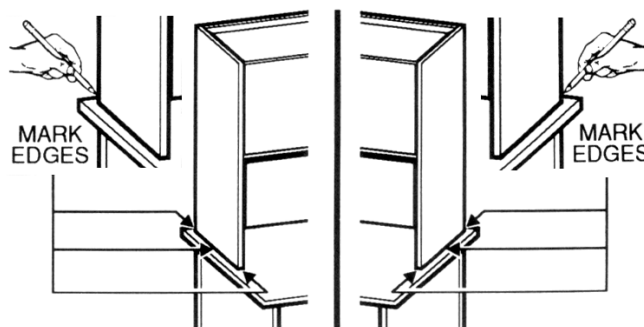

- B.** Use a pencil to mark the location of the front, back and outside edges of the hutch sides onto the desktop.

- C.** With the assistance of another person, lift the hutch off the desk. Lay the hutch down on its back. Remove backing from one side of each Tape Strip (H10) and place on the bottom edges of the Left Side (A) and the Right Side (B).

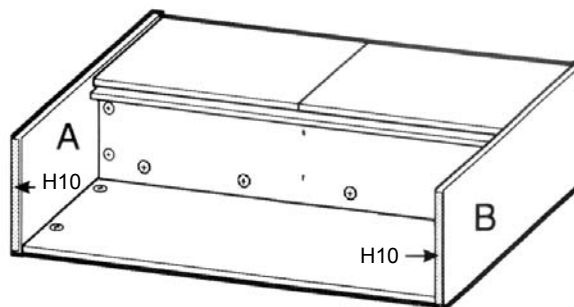

- D.** Remove the backing from other side of each Tape Strip. With the assistance of another person, very carefully align the hutch onto the pencil markings of the desktop. When aligned, place the hutch on the desk unit.

**IMPORTANT!** It will be difficult to remove or reposition the units once joined.

