

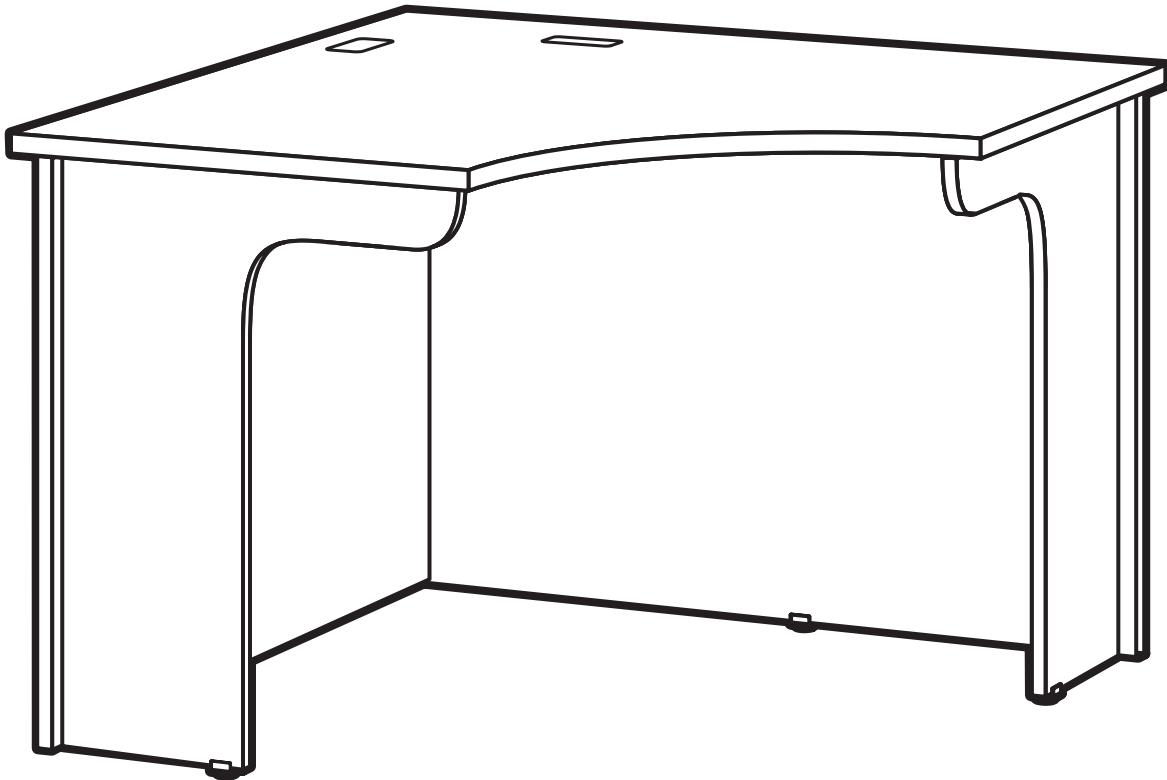

M4242

CORNER UNIT



IMPORTANT!

Assembly may require the assistance of another person.

Before you begin assembly:

READ THE DIRECTIONS all the way through one time. This will speed up the process and help you understand the sequence of steps.

COUNT THE PARTS AND HARDWARE before assembly. This ensures you have received all necessary parts before you begin.

TOOLS: You may need a Phillips head screwdriver, a medium slotted screwdriver or a plastic mallet. To protect your new furniture from damage during assembly, it is recommended to work on a carpeted surface.

In the event any parts are missing from this package, send your name, address, telephone number, and a description of the missing part(s) to: PARTS, Box 1420, Missoula, MT 59806 or call: 1-800-769-5693 or FAX 1-800-445-5281.

CAUTION: On assemblies requiring glue, make sure the unit is assembled correctly before gluing. Once this unit is assembled with glue, the manufacturer will not be responsible for damaged parts. Keep a damp cloth or sponge handy to wipe off excess glue.

To care for this furniture, simply wipe with a cloth dampened with glass cleaner containing ammonia-D.

PARTS DIAGRAM

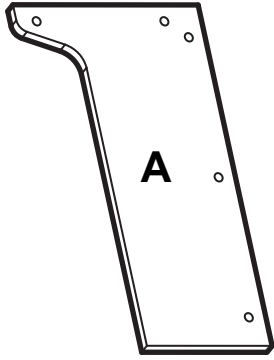

Left End Panel	02320241	1 ea.
----------------	----------	-------

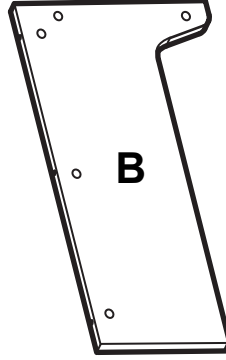

Left End Panel	02320241	1 ea.
----------------	----------	-------

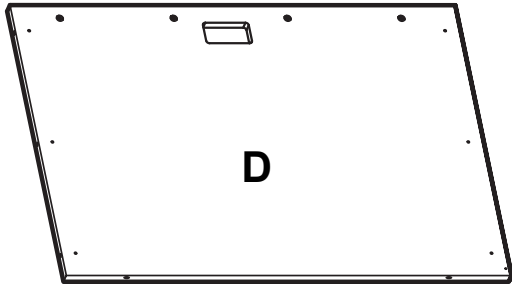

Left Back Panel	02320253	1 ea.
-----------------	----------	-------

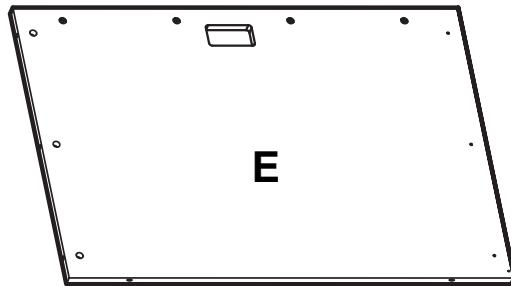

Right Back Panel	02320254	1 ea.
------------------	----------	-------

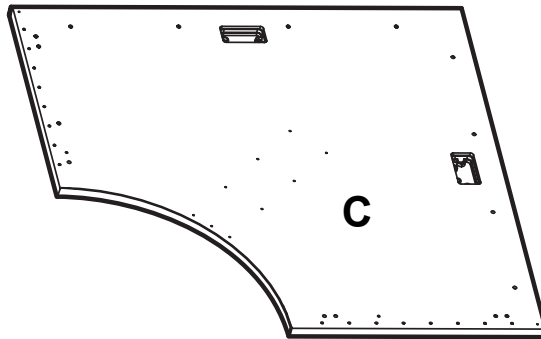

Top	02320201	1 ea.
-----	----------	-------



H6	Small Leveler Bracket	402303	4 ea.
----	-----------------------	--------	-------



H1	Minifix Bolt	909834	21 ea.
----	--------------	--------	--------



H8	Minifix Cam	909810	21 ea.
----	-------------	--------	--------



H4	#8 x 3/4" Panhead Screw	901208	40 ea.
----	-------------------------	--------	--------



H9	Large Leveler Bracket	402302	4 ea.
----	-----------------------	--------	-------

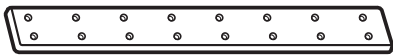

H3	18" Connector Plate	411270	2 ea.
----	---------------------	--------	-------



H2	Wood Dowel	195000	2 ea.
----	------------	--------	-------



H5	Leveler Insert	274650	8 ea.
----	----------------	--------	-------

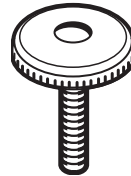

H7	Leveler	300870	8 ea.
----	---------	--------	-------

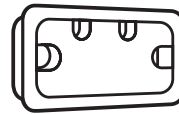

H11	Grommet Cover	286580	4 ea.
-----	---------------	--------	-------



H10	J-Bracket	411470	2 ea.
-----	-----------	--------	-------

Using the Minifix System:

Insert the Minifix Cams into the appropriate holes with the arrow facing outwards as shown.

When screwing post into hole, **Do Not** over tighten. Screw post down until bottom face of post flange just touches board surface.

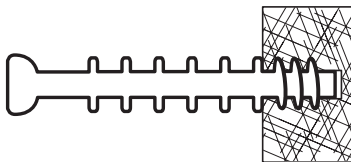

Using the #2 Phillips screwdriver, rotate the Cam Devices a half turn clockwise until snug.

To disassemble, turn the Cam Devices counter-clockwise and remove panels.

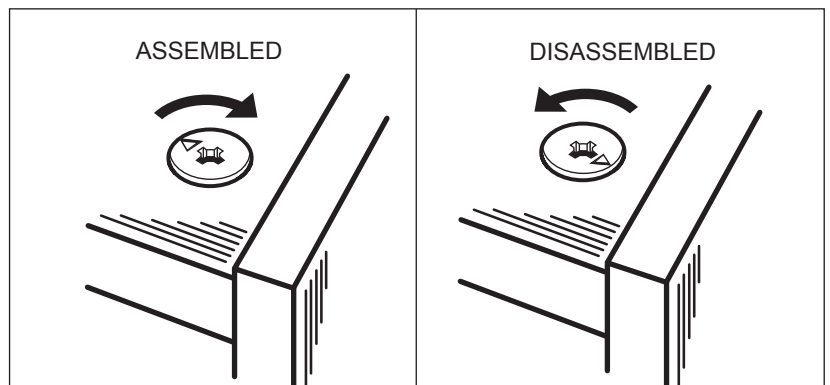
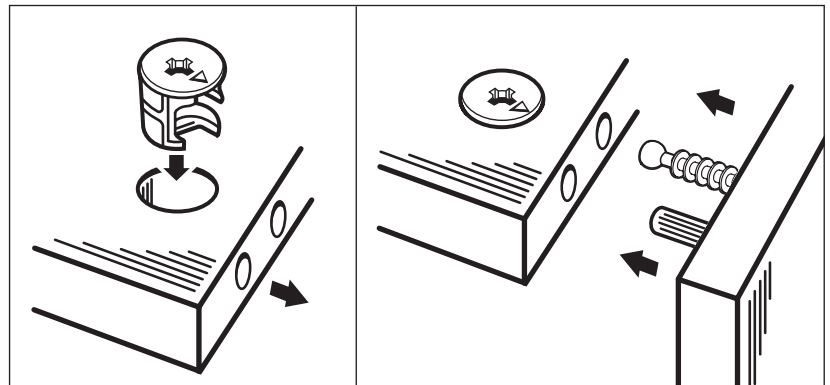

#1

Place the Top Panel (C) on a clean, carpeted surface or foam padding with the pre-drilled holes facing up. Using a screwdriver, screw twelve Minifix Bolts (H1) into the Top (C) where indicated.

Insert two Wood Dowels (H2) into the Top where indicated.

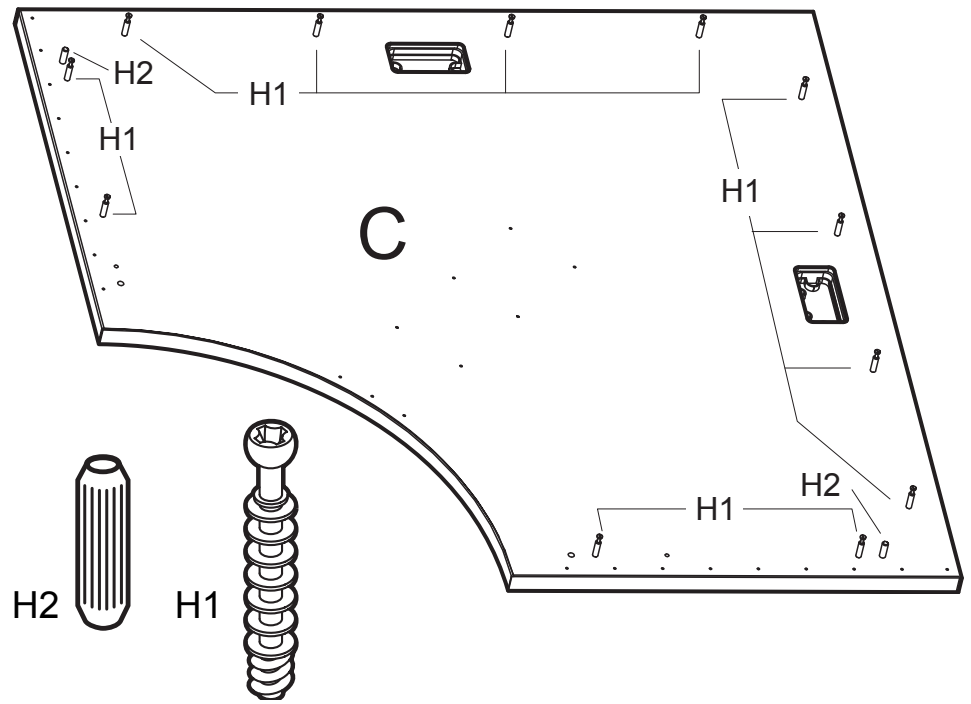

#2

Position the 18" Connector Plates (H3) in the locations appropriate to the units to be attached. Secure Connector Plates in place using #8x3/4" Panhead Screws (H4) in the pre-drilled holes of the Top (C).

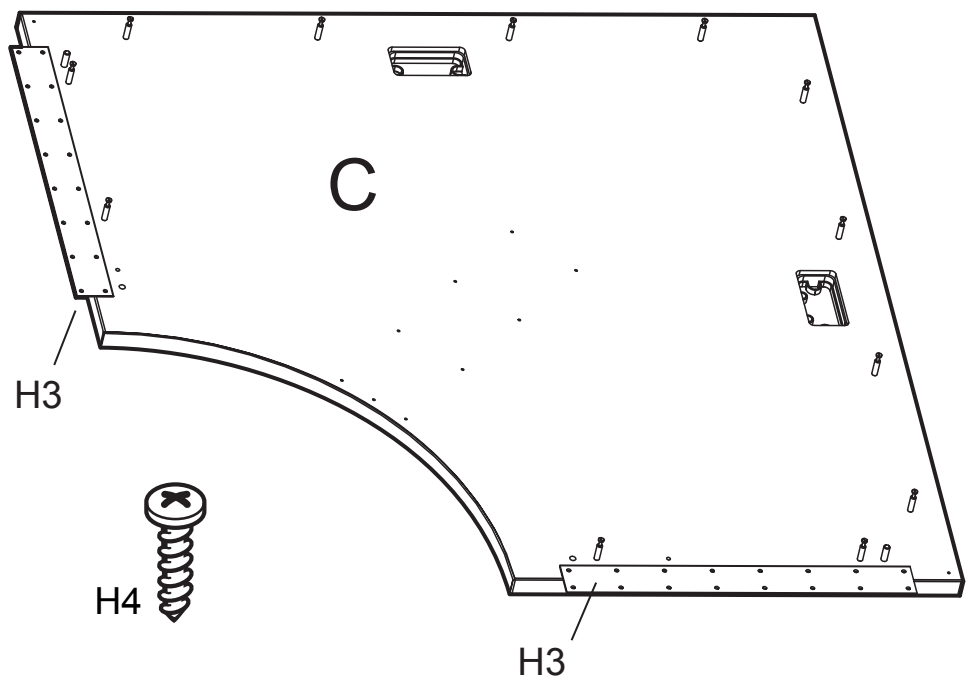

#3

Insert the Leveler Inserts (H5) into the holes in the bottom edges of the Left and Right Back Panel (D & E) and using a plastic mallet, tap until flush with the surface. Press a Small Leveler Bracket (H6) over each Leveler Insert. Screw the Levelers (H7) into the Leveler Inserts. **Adjust Levelers when the assembled unit is in place.**

Screw the Levelers (H7) into the Leveler Inserts. **Adjust Levelers when the assembled unit is in place.**

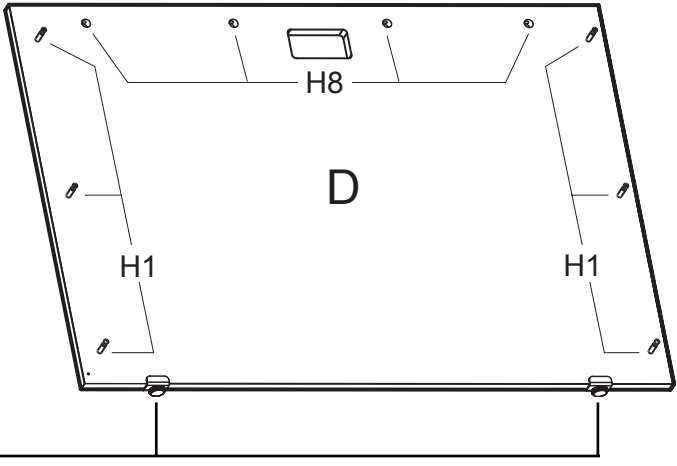
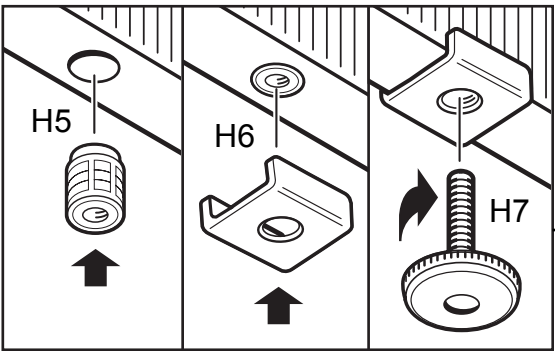

Insert Minifix Cams (H8) into the Left and Right Panel (D & E) with the arrows of the cams facing out.

Screw Minifix Bolts (H1) into each panel where indicated.

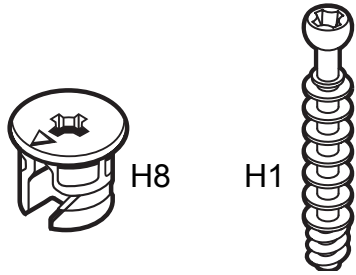
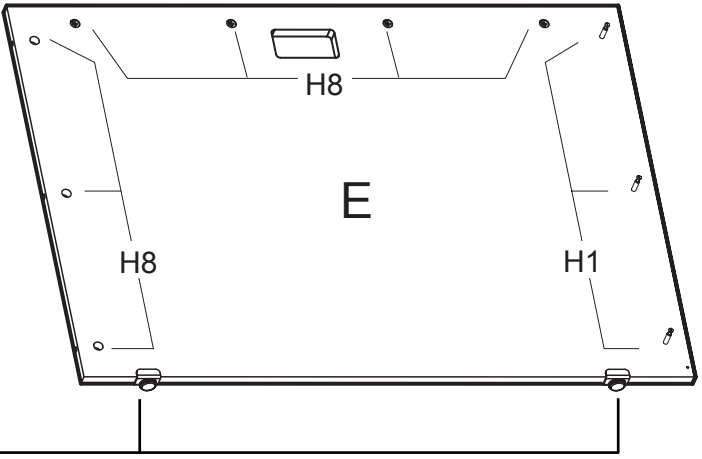
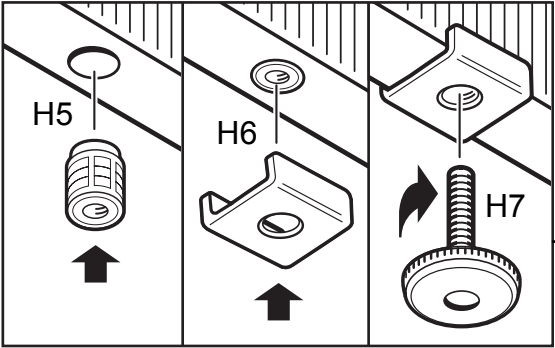

#4

Insert the Leveler Inserts (H5) into the holes in the bottom edge of the Left End Panel (A) and the Right End Panel (B) and using a plastic mallet, tap until flush with the surface. Press a Large Leveler Bracket (H9) over each Leveler Insert. Press a Large Leveler Bracket (H9) over each Leveler Insert.

Screw the Levelers (H7) into the Leveler Inserts. **Adjust Levelers when the assembled unit is in place.**

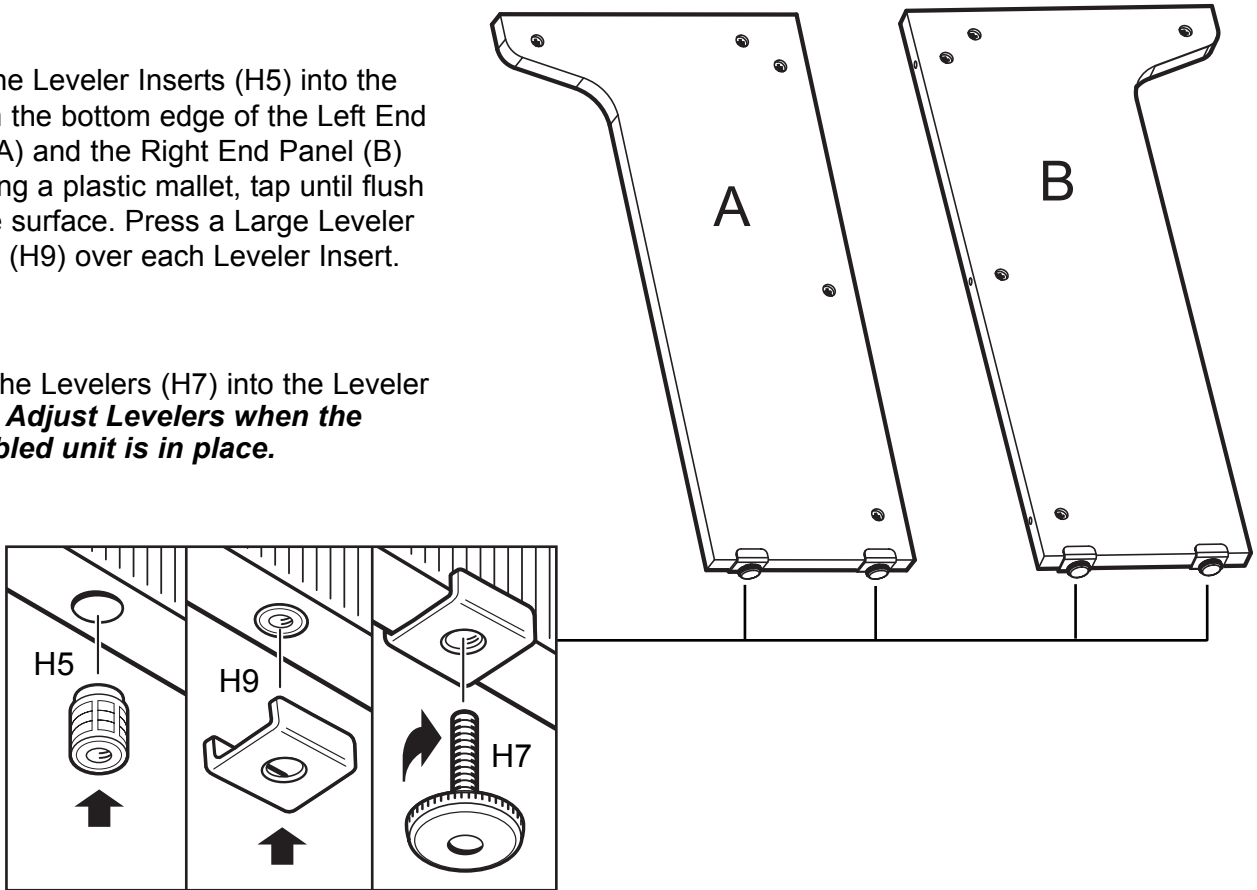

#5

Insert Minifix Cams (H8) into the Left End Panel (A) and the Right End Panel (B) with the arrows of the cams facing out.

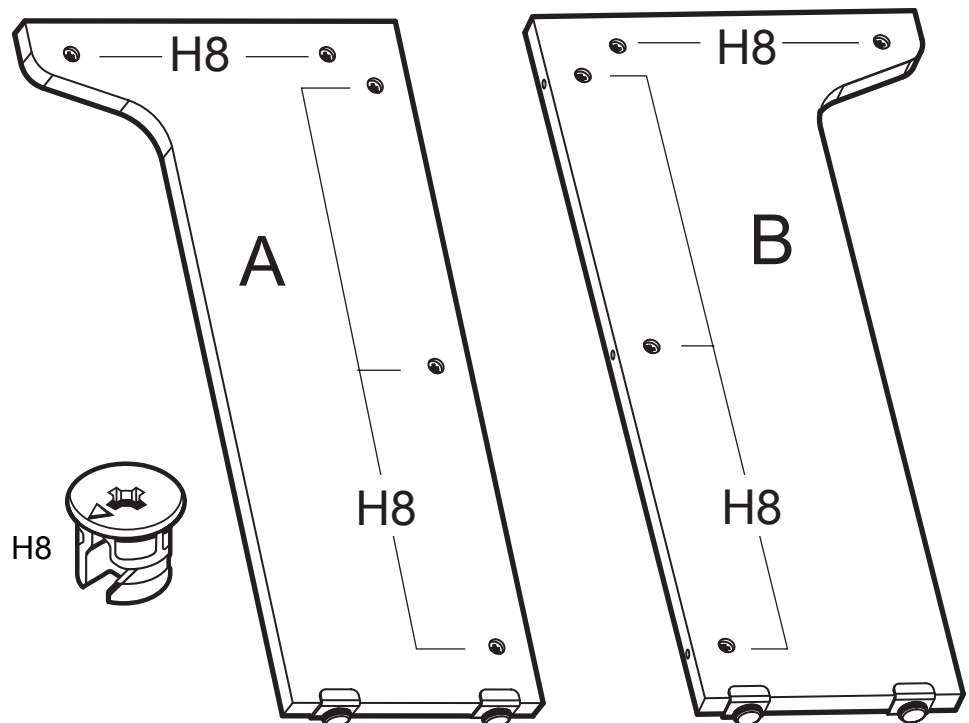

#6

Attach Back Panels (E & F) and Side Panels (A & B) as shown. Turn Minifix Cams (H8) clockwise to secure.

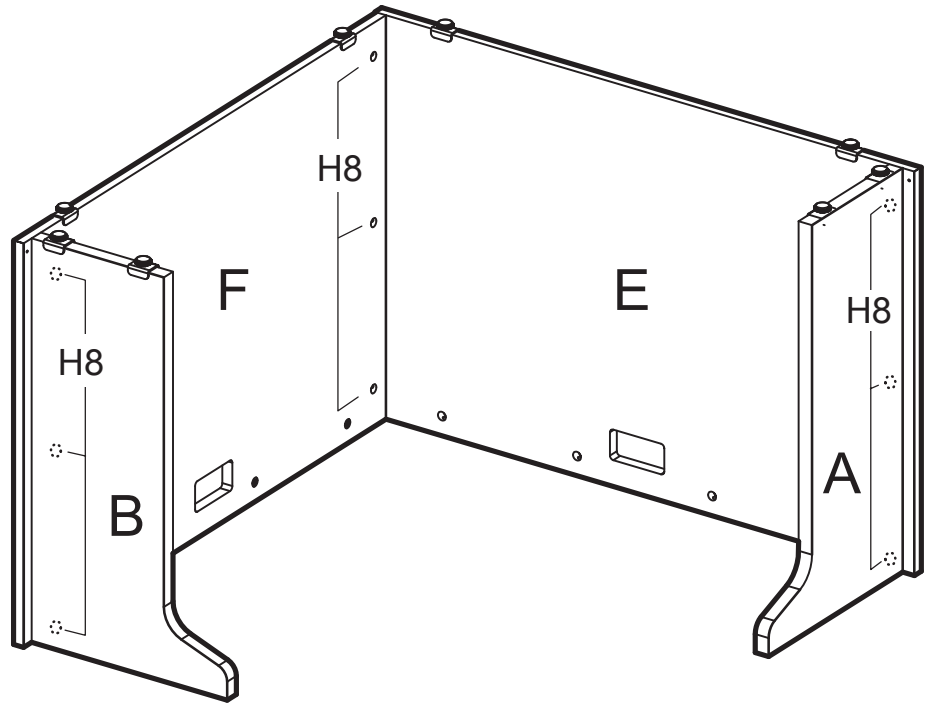

#7

With the assistance of another person, set the Side /Backs assembly onto the posts and dowels of the Top. Tighten the twelve Minifix Cams (H8) as shown.

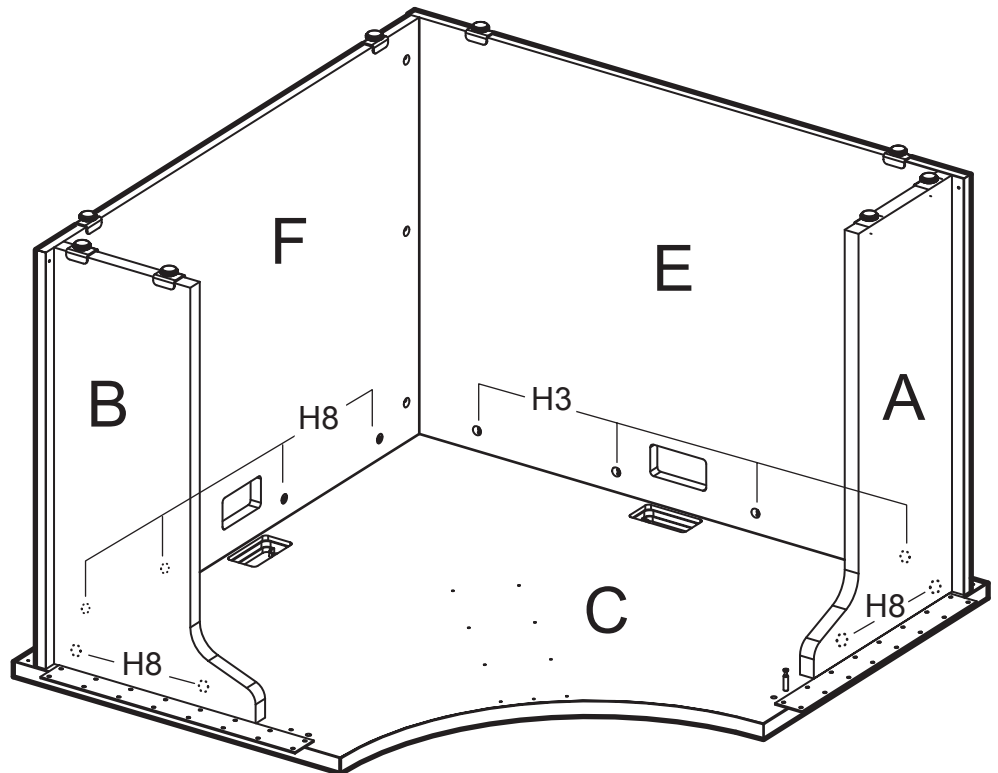

#8

Attach a "J" Bracket (H10) to each end of the unit using #8x3/4" Panhead Screws (H4) as shown.

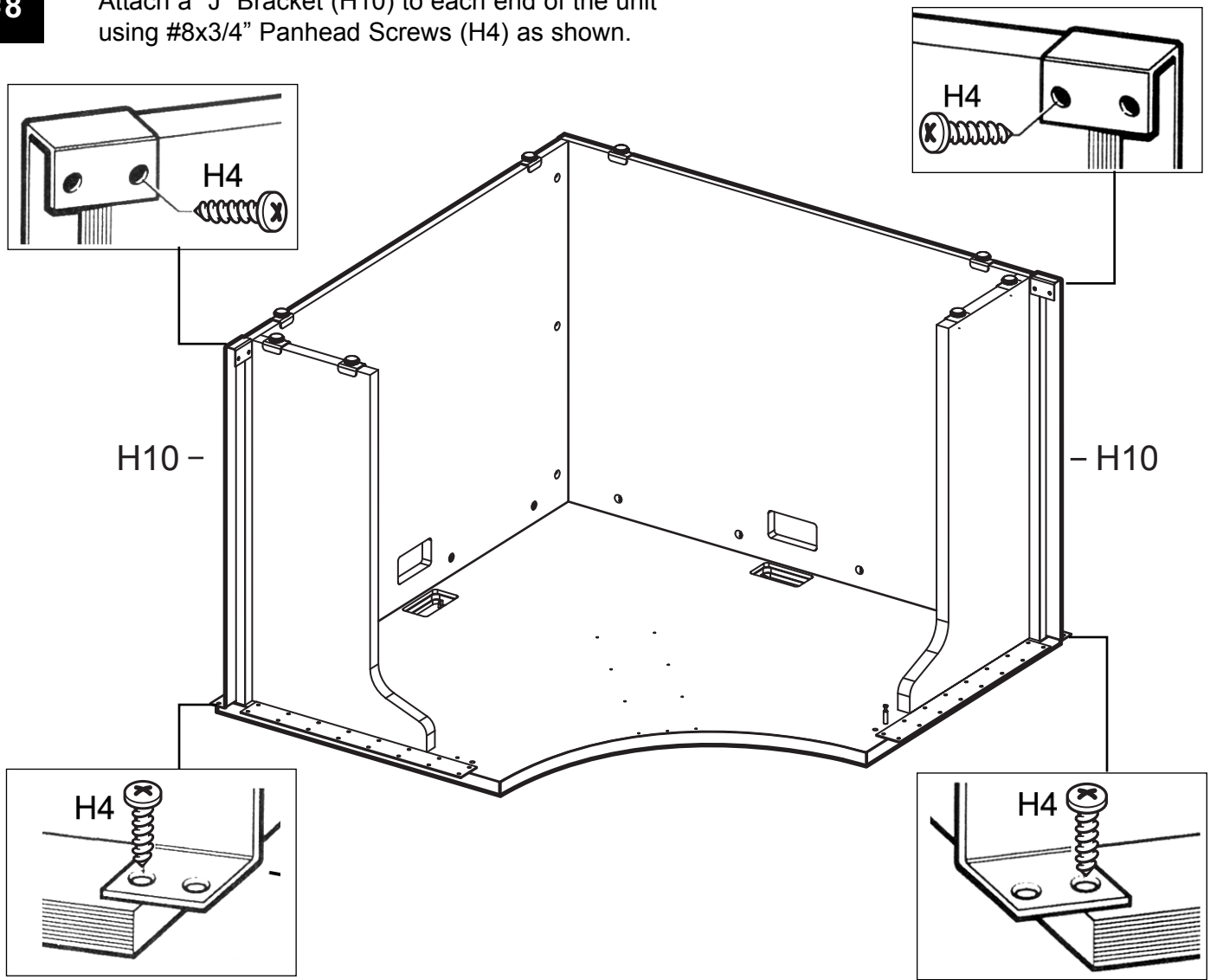

#9

With the assistance of another person, turn the unit upright. Insert Grommets (H11) into the Top (C), the Left Back Panel (E) and the Right Back Panel (F).

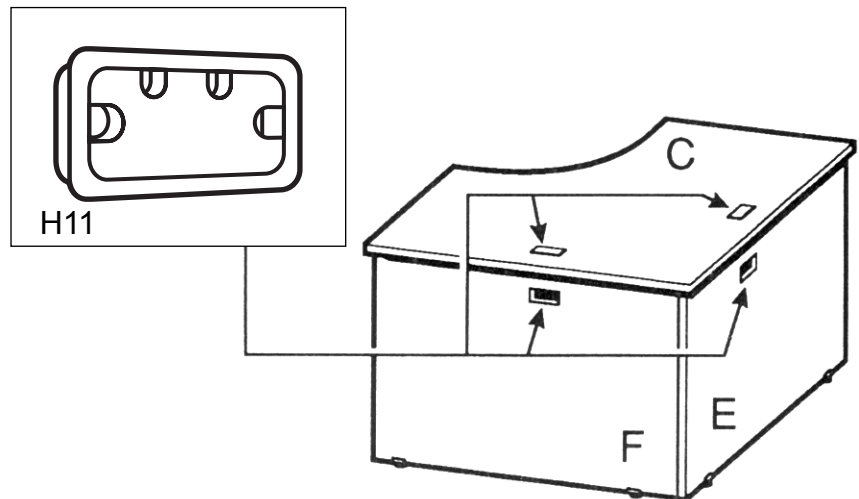

#10

CONNECTING OTHER UNITS:

Remove the side panel (and associated hardware) from the attaching end of the desk shell to be connected. Position the Top Panel and the Back Panel of the desk shell simultaneously into the "J" Bracket (H10) and onto the Connector Plate (H3) of the corner unit. Slide the back panel of the desk into the "J" Bracket of the corner unit. Secure the desk shell to the corner unit using #8 x 3/4" Panhead Screws (H4) through the Connector Plates and into the pre-drilled holes of the underside of the desk shell top.

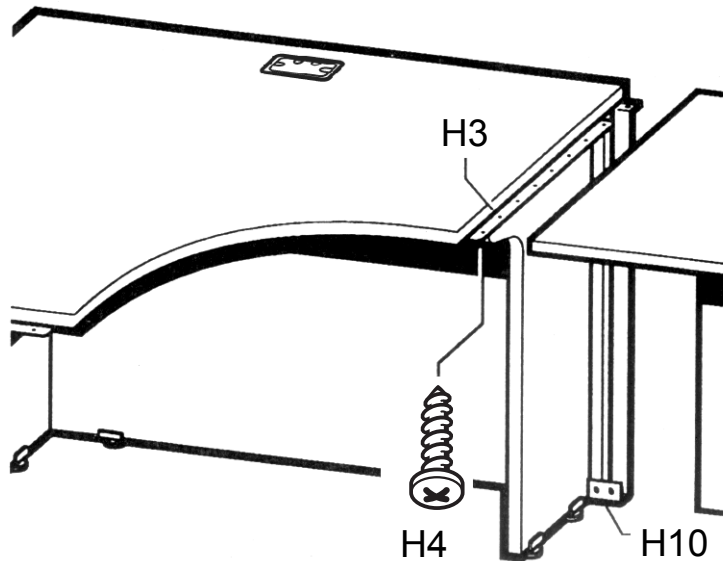

Secure the "J" Bracket to the desk shell using two #8x3/4" Panhead Screws.

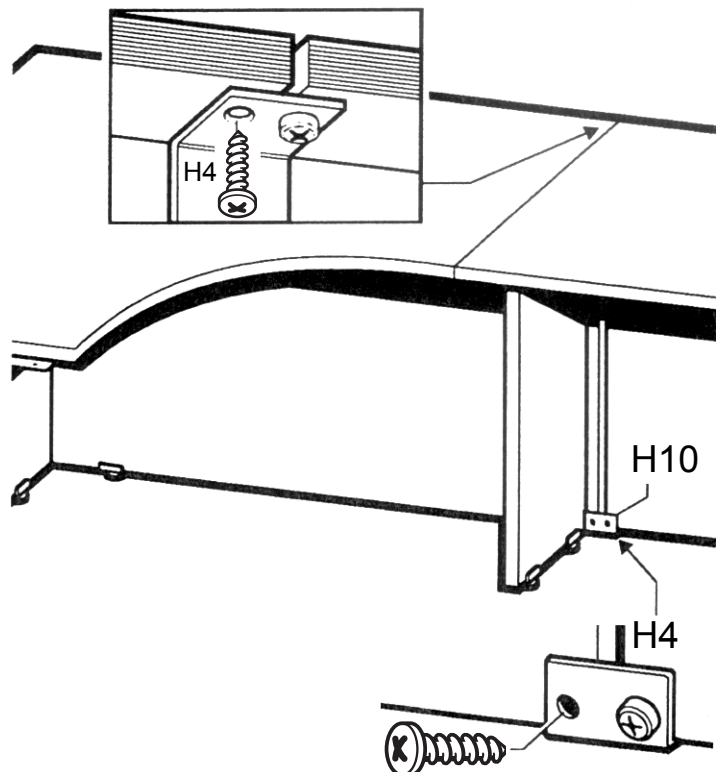

Attach the other desk shell to the other side of the Corner Connector in the same manner.