

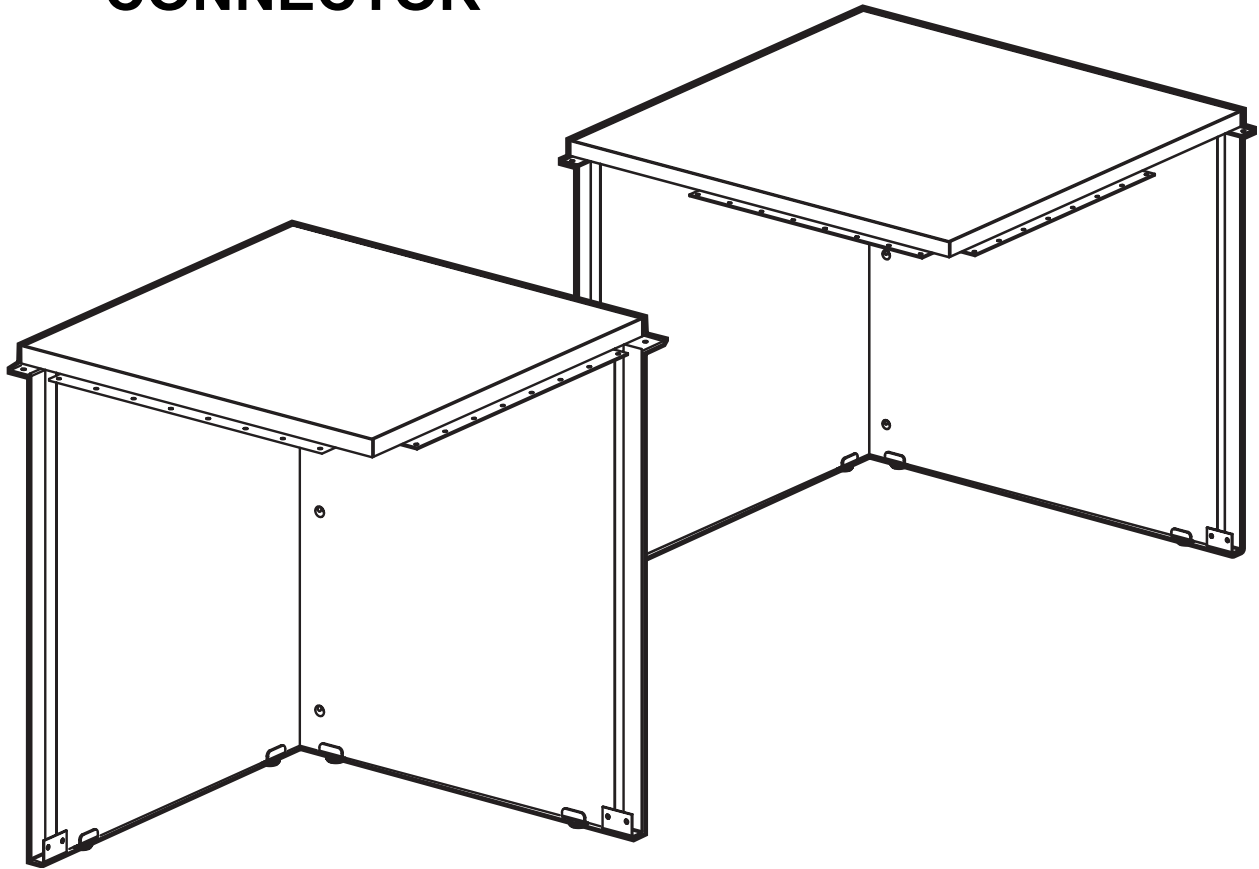

M2424 M3030

CORNER CONNECTOR



IMPORTANT!

Assembly may require the assistance of another person.

Before you begin assembly:

READ THE DIRECTIONS all the way through one time. This will speed up the process and help you understand the sequence of steps.

COUNT THE PARTS AND HARDWARE before assembly. This ensures you have received all necessary parts before you begin.

TOOLS: You may need a Phillips head screwdriver, a medium slotted screwdriver or a plastic mallet. To protect your new furniture from damage during assembly, it is recommended to work on a carpeted surface.

In the event any parts are missing from this package, send your name, address, telephone number, and a description of the missing part(s) to: PARTS, Box 1420, Missoula, MT 59806 or call: 1-800-769-5693 or FAX 1-800-445-5281.

CAUTION: On assemblies requiring glue, make sure the unit is assembled correctly before gluing. Once this unit is assembled with glue, the manufacturer will not be responsible for damaged parts. Keep a damp cloth or sponge handy to wipe off excess glue.

To care for this furniture, simply wipe with a cloth dampened with glass cleaner containing ammonia-D.

PARTS DIAGRAM

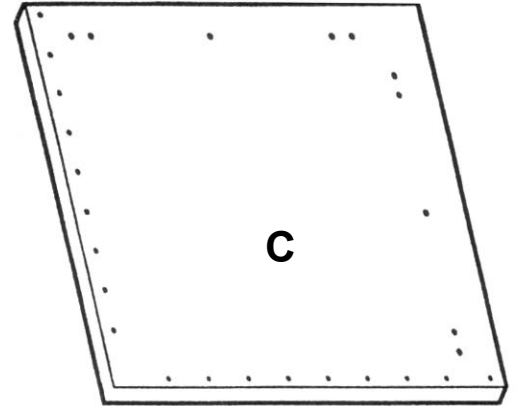
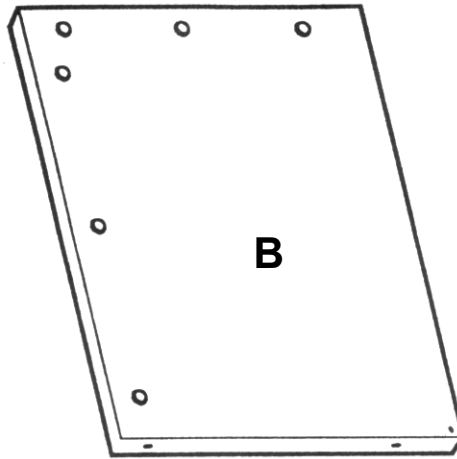
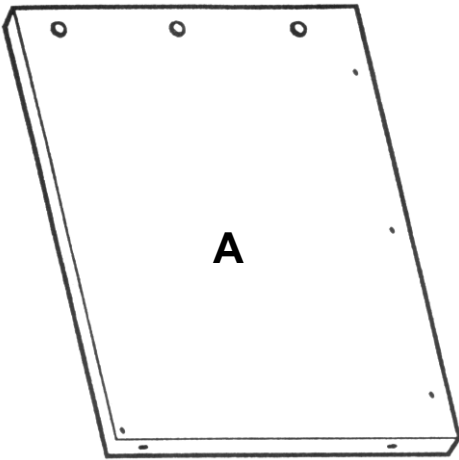

Left Back Panel	M2424 M3030	02320153 02320553	1 ea.
-----------------	----------------	----------------------	-------

Right Back Panel	M2424 M3030	02320154 02320564	1 ea.
------------------	----------------	----------------------	-------

Top Panel	M2424 M3030	02320101 02320501	1 ea.
-----------	----------------	----------------------	-------



H1	Minifix Bolt	909834	9 ea.
----	--------------	--------	-------

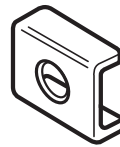

H6	Small Leveler Bracket	402303	4 ea.
----	-----------------------	--------	-------



H8	Minifix Cam	909810	9 ea.
----	-------------	--------	-------



H5	Leveler Insert	274650	4 ea.
----	----------------	--------	-------

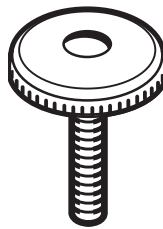

H7	Leveler	300870	4 ea.
----	---------	--------	-------



H4	#8 x 3/4" Panhead Screw	901208	40 ea.
----	----------------------------	--------	--------



H2	Wood Dowel	195000	4 ea.
----	------------	--------	-------



H9	J-Bracket	411470	2 ea.
----	-----------	--------	-------

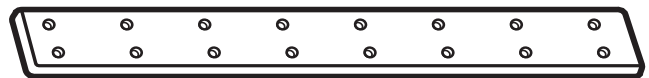

H3	18" Connector Plate	411270	2 ea.
----	---------------------	--------	-------

Using the Minifix System:

Insert the Minifix Cams into the appropriate holes with the arrow facing outwards as shown.

When screwing post into hole, **Do Not** over tighten. Screw post down until bottom face of post flange just touches board surface.

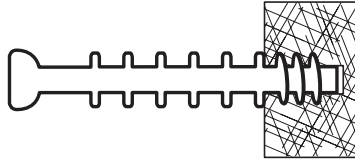

Using the #2 Phillips screwdriver, rotate the Cam Devices a half turn clockwise until snug.

To disassemble, turn the Cam Devices counter-clockwise and remove panels.

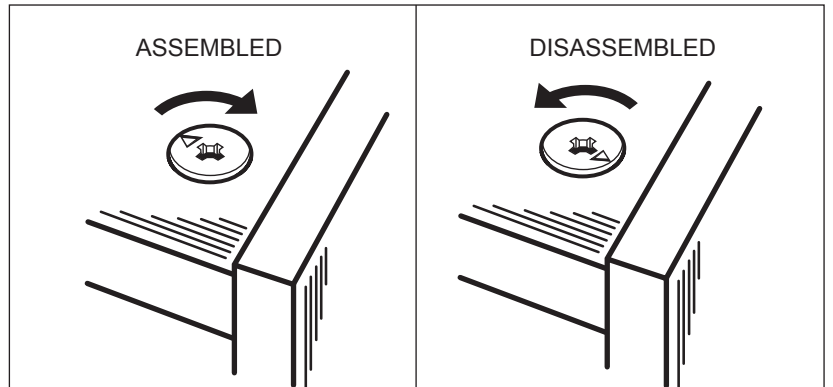
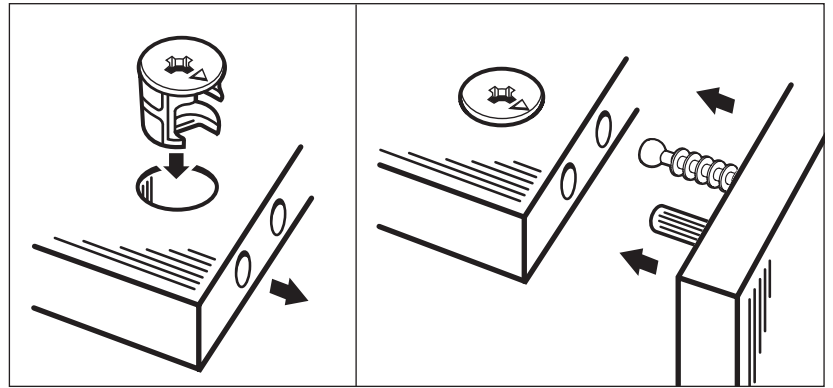

#1

Place the Top Panel (C) on a clean, carpeted surface or foam padding with the pre-drilled holes facing up. Using a screwdriver, screw six Minifix Bolts (H1) into the Top Panel where indicated.

Insert four Wood Dowels (H2) into the Top Panel where indicated.

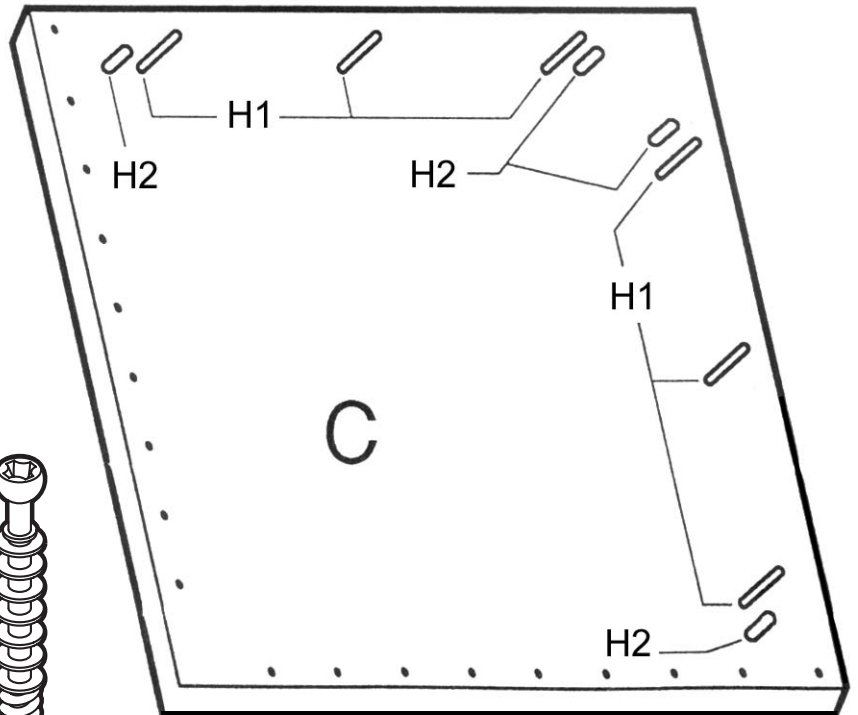
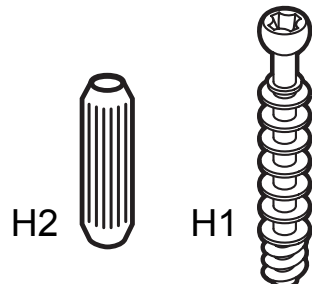

#2

Position the 24" Connector Plates (H3) on both sides of the Top Panel (C) as shown. Secure the 24" Connector Plates in place using #8 x 3/4" Panhead Screws (H4) in the pre-drilled holes of the Top Panel.

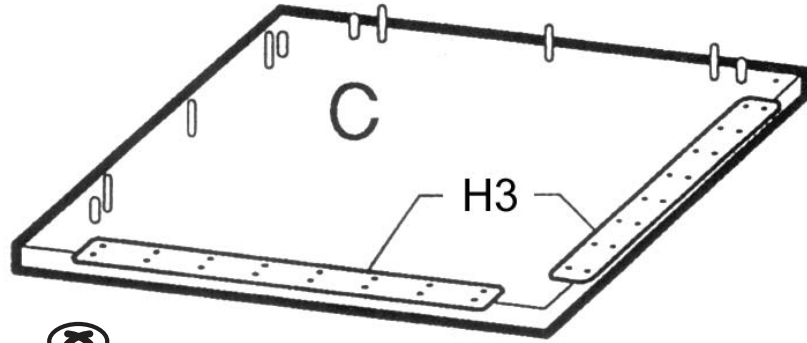

#3

Insert Minifix Cams (H8) into the Left Back Panel (B) and Right Back Panel (A) facing out as shown.

Insert three Minifix Bolts (H1) into the Right Back Panel (A) as shown.

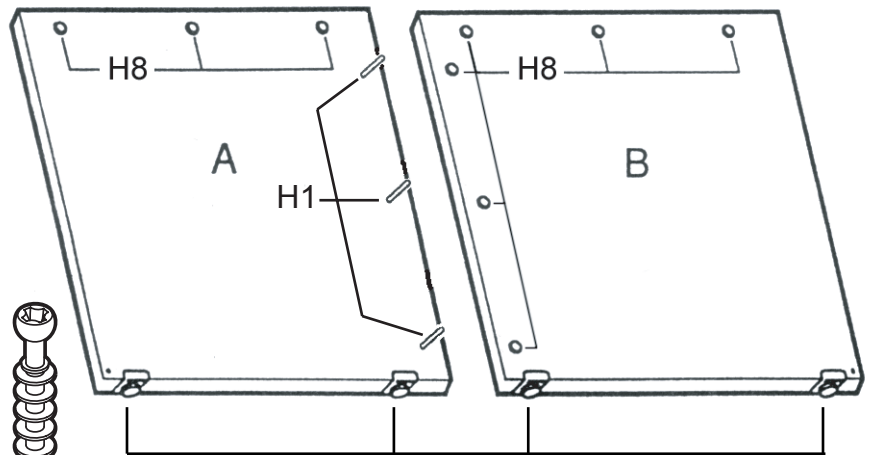

H1



Insert the Leveler Inserts (H5) and Leveler Brackets (H6) into the holes in the bottom edges of Left Back Panel (B) and Right Back Panel (A) and tap into place.

Screw the Levelers (H7) into the Leveler Inserts.

Adjust Levelers when the assembled unit is in place.

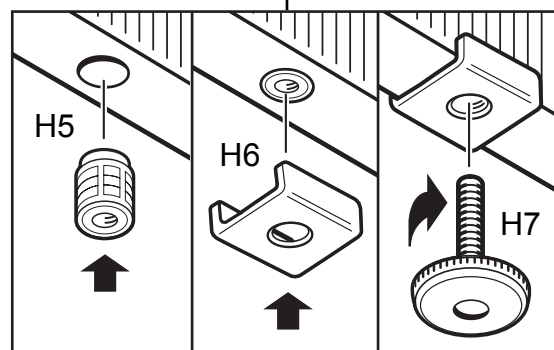

#4

Attach the Left Back (A) to the Right Back (B) as shown. Turn the cams (H8) clockwise to secure.

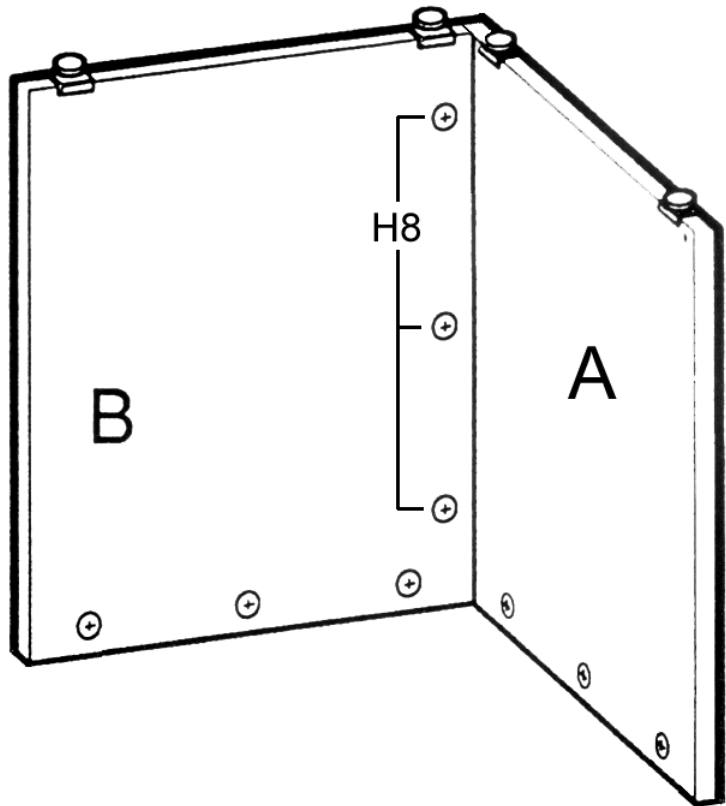

#5

Position the Back Panels (A & B) onto the posts and dowels of the Top Panel (C) and turn the cams (H8) clockwise to secure.

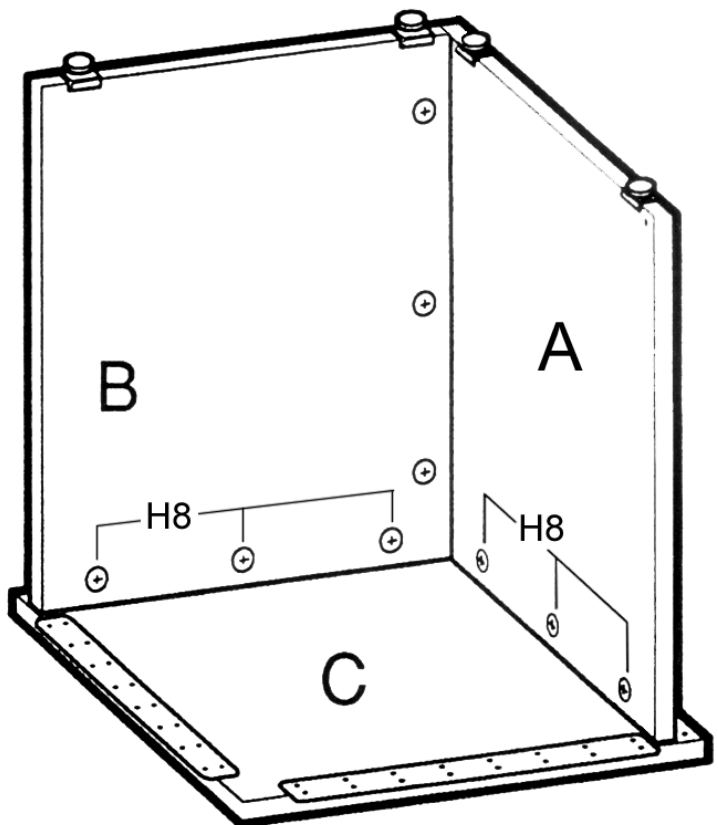

#6

Attach a "J" Bracket (H9) to Left Back Panel (B) and Top Panel (C) using #8 x 3/4" Panhead Screws (H4) into the pre-drilled holes.

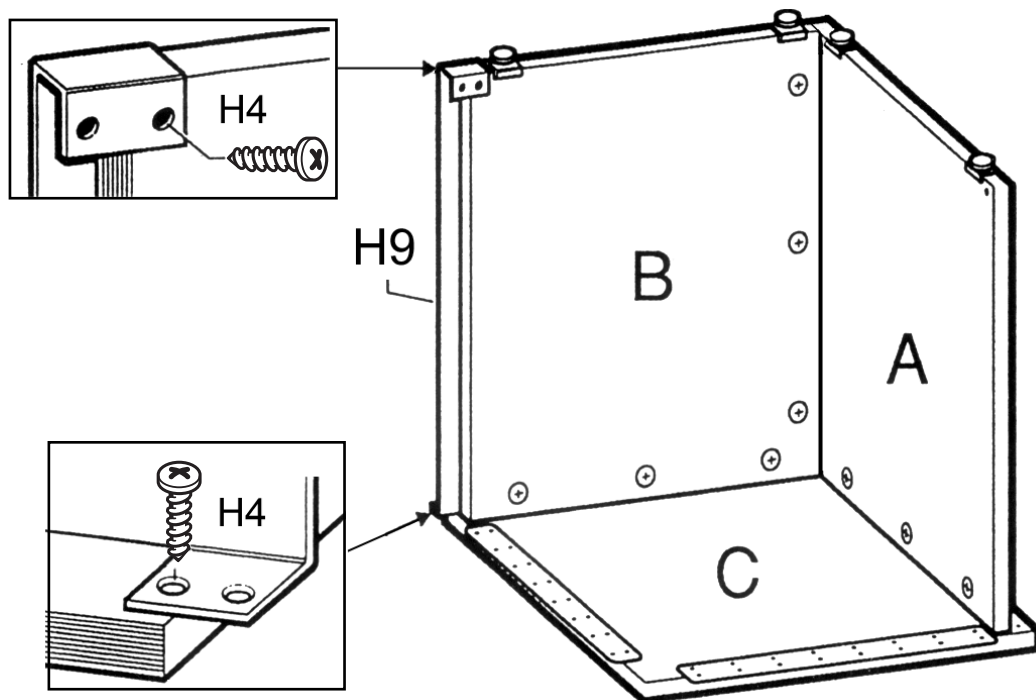

#7

Attach a "J" Bracket (H9) to the Right Back Panel (A) and the Top Panel (C) using #8 x 3/4" Panhead Screws (H4) into the pre-drilled holes.

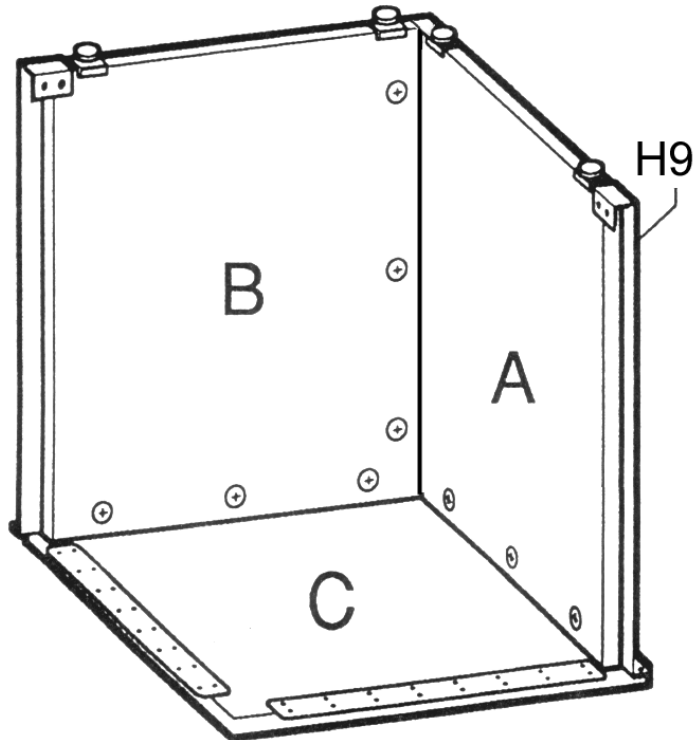

CONNECTING TO OTHER UNITS:

Position the top panel and the back panel of the desk shell simultaneously into the "J" Bracket and onto the Connector Plate of the corner unit. Slide the back panel of the desk into the "J" Bracket of the corner unit. Secure the desk shell to the corner unit using #8 x 3/4" Panhead Screws through the Connector Plate and into the pre-drilled holes of the underside of the desk shell top.

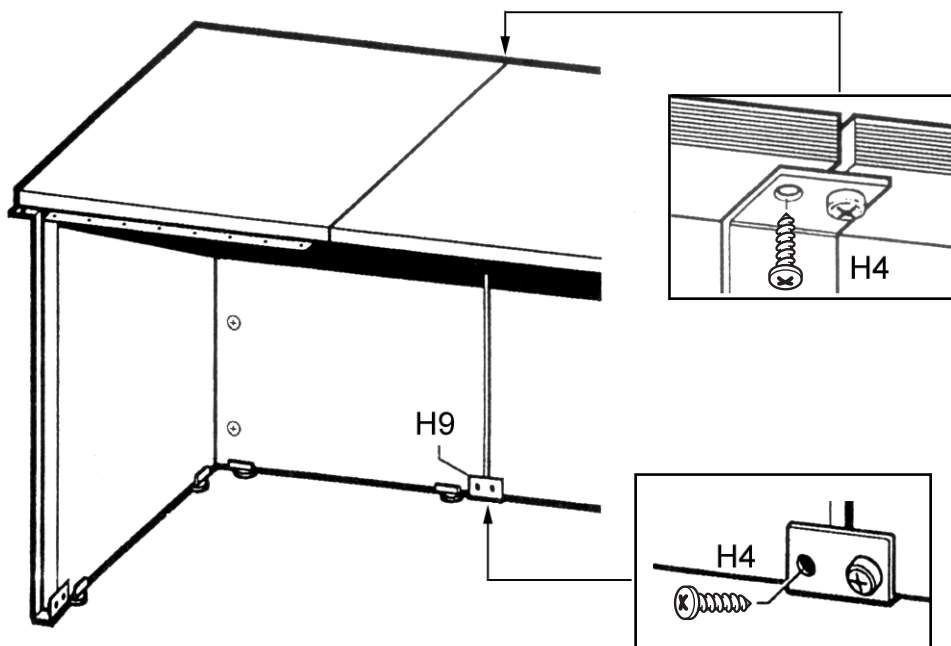
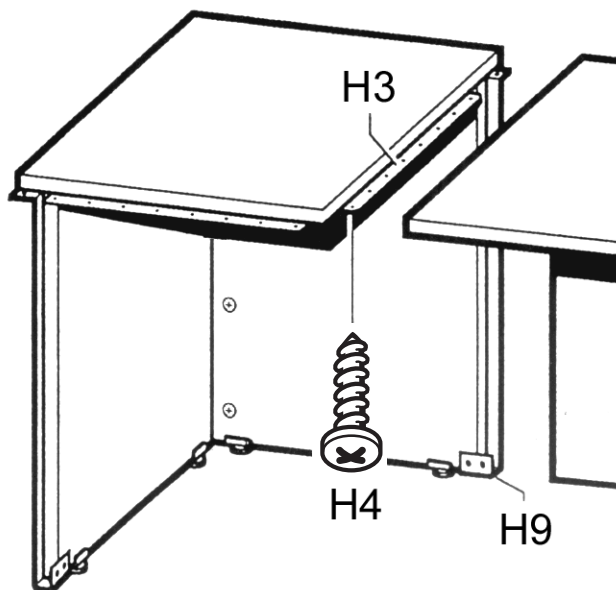

Secure the "J" Bracket to the desk shell using two #8 x 3/4" Panhead Screws(H4).

Attach the adjoining unit to the other side of the Modular Bridge in the same manner.