

4072-0

Open-Tote Tray Mobile

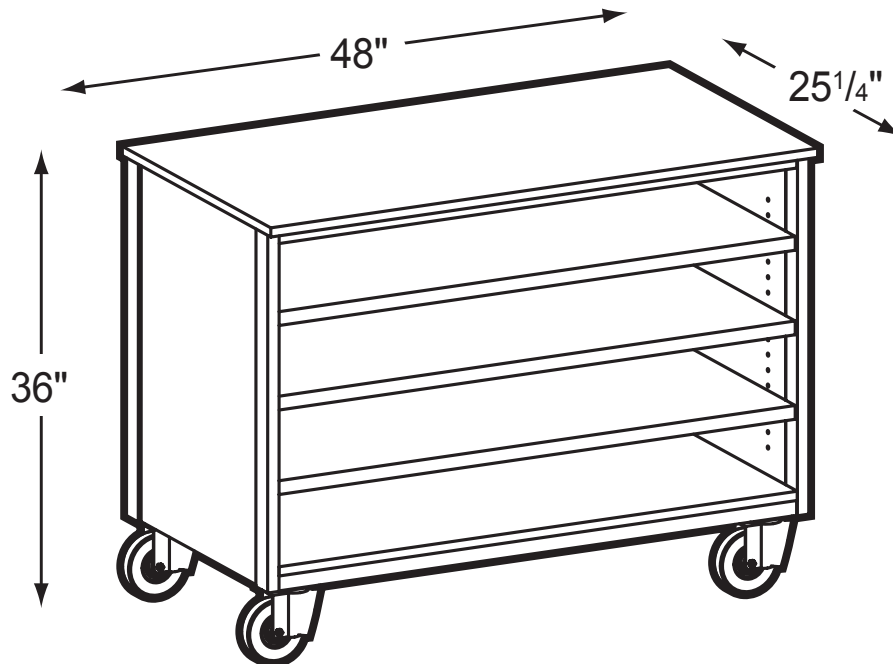

Product Specs

- Fully welded unitized frame
 - 16 ga. tubing
 - 10 ga. angle iron
 - 18 ga. vertical side support channels
 - 18 ga. J channel for lower edge of back
 - 3/16" caster mounting plates
 - 5" casters (2 locking)
 - 5mm steel shelf supports
 - 3/4" thermal fused laminate
 - 3mm PVC edge banding on all semi and exposed edges
 - Three adjustable shelves
- Trays not included:
- 3 - T-102 tray per shelf or bottom
 - 4 - T-132 tray per shelf or bottom
 - 5 - T-100 tray per shelf or bottom