

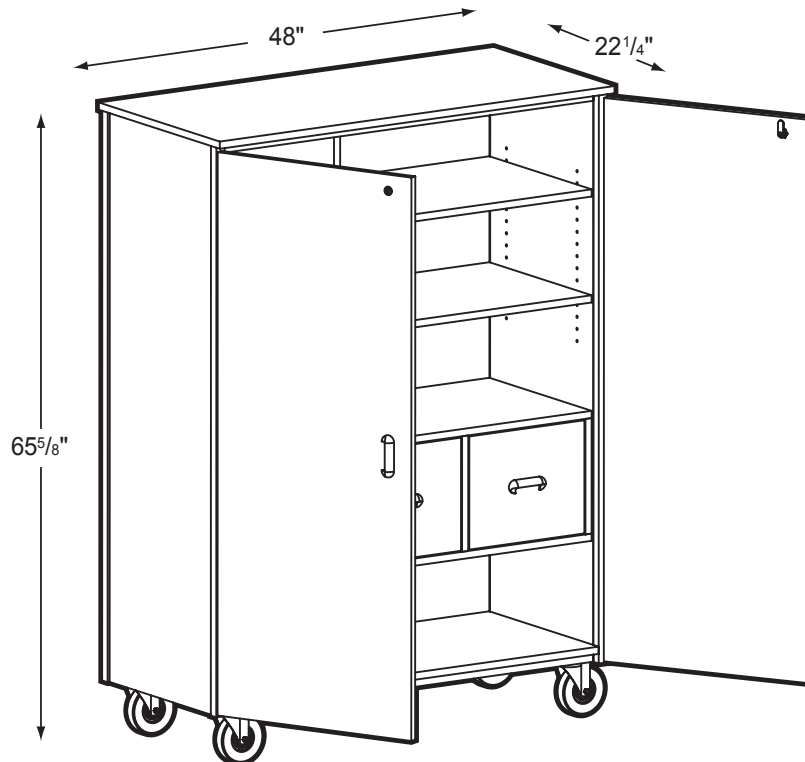

2086-CL

Teacher Storage



Product Specs

- Fully welded unitized top and bottom frame
- 10 ga. angle iron
- 3/16" caster mounting plates
- 5" casters (2 locking)
- 5mm steel shelf supports
- 5 knuckle hinges w/hospital tips
- Triple bar magnetic catch
- Hooded abs plastic four fingered pull
- Five disk cam lock
- 14" steel closet rod
- 12" x 12" mirror
- 100# rated full extension drawer slides
- 3/4" thermal fused laminate
- 3mm PVC edge banding on all semi and exposed edges
- Two adjustable shelves 2/3 width
- 14" hat shelf
- Two letter size file drawers

0208