



IRONWOOD
MANUFACTURING

MOBILE 2000 SERIES

2038-CL

Closed-Double Faced Combo Unit w/Locks

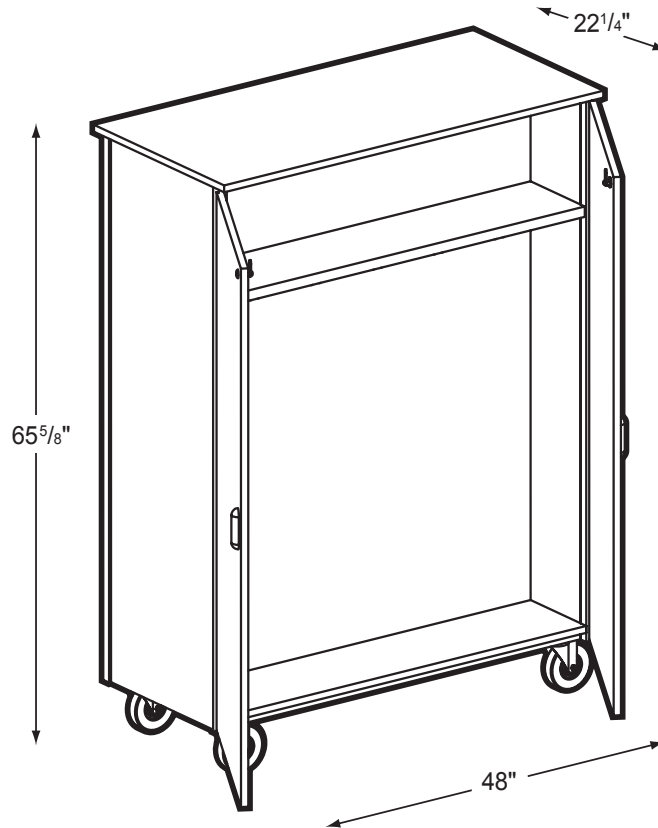

Product Specs

- Fully welded unitized top and bottom frame
- 16 ga. tubing
- 10 ga. angle iron
- 3/16" caster mounting plates
- 5" casters (2 locking)
- 5 knuckle hinges w/hospital tips
- Triple bar magnetic catch
- Hooded abs plastic four fingered pull
- Five disk cam lock
- Cast double prong coat hook
- 3/4" thermal fused laminate
- 1" thermal fused laminate on shelves over 32"
- 3mm PVC edge banding on all semi and exposed edges
- Four adjustable shelves on one side
- One fixed shelf w/5 hooks on one side

0309