

# 2036-0

## Open-Wardrobe

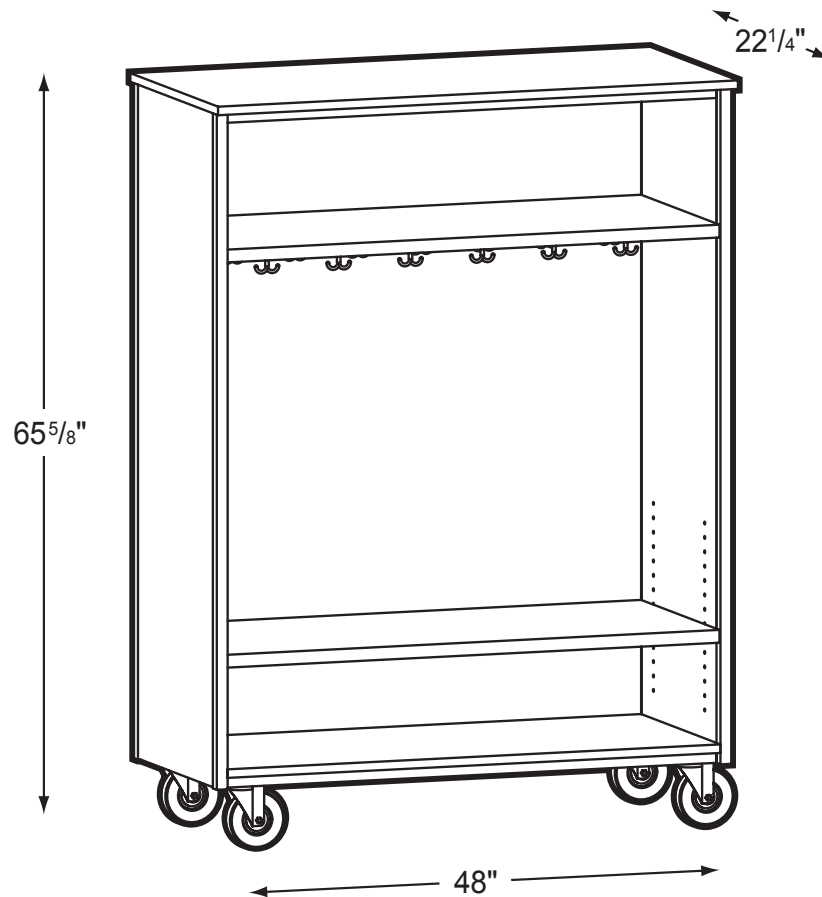

### Product Specs

- Fully welded unitized top and bottom frame
- 16 ga. tubing
- 10 ga. angle iron
- 3/16" caster mounting plates
- 5" casters (2 locking)
- 5mm steel shelf supports
- Cast double prong coat hook
- 3/4" thermal fused laminate
- 1" thermal fused laminate on shelves over 32"
- 3mm PVC edge banding on all semi and exposed edges
- One adjustable shelf
- One fixed shelf w/13 hooks

0309