

1044-O

Open-General Storage

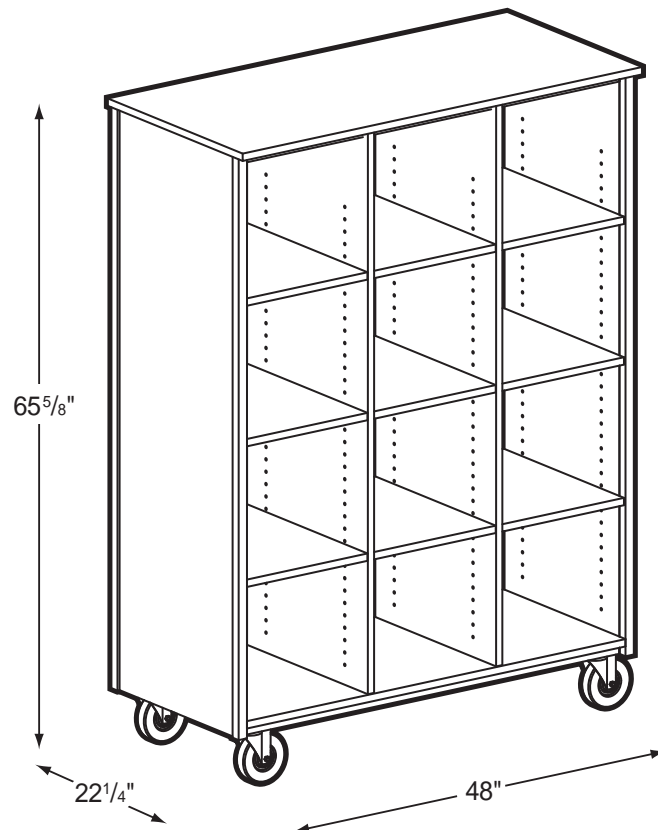

Product Specs

- Fully welded unitized frame
- 10 ga. angle iron
- 3/16" caster mounting plates
- 5" casters (2 locking)
- 5mm steel shelf supports
- 3/4" thermal fused laminate
- 1" thermal fused laminate on shelves over 32"
- 3mm PVC edge banding on all semi and exposed edges
- Nine 1/3 width adjustable shelves