

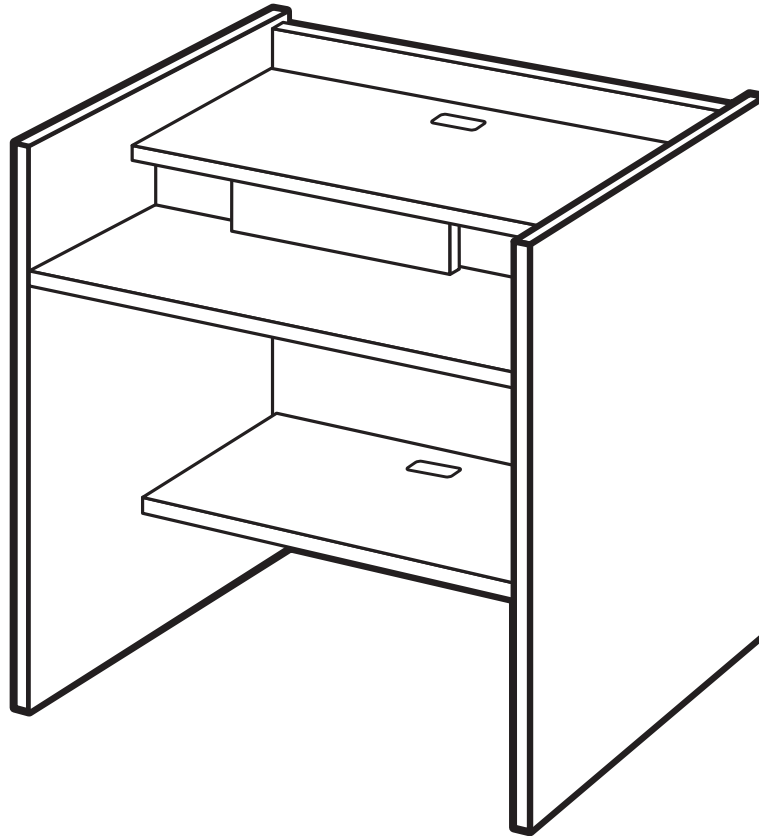

PA3632-PA3639

PATRON ACCESS STATION



IMPORTANT!

Assembly may require the assistance of another person.

Before you begin assembly:

READ THE DIRECTIONS all the way through one time. This will speed up the process and help you understand the sequence of steps.

COUNT THE PARTS AND HARDWARE before assembly. This ensures you have received all necessary parts before you begin.

TOOLS: You may need a Phillips head screwdriver, a medium slotted screwdriver or a plastic mallet. To protect your new furniture from damage during assembly, it is recommended to work on a carpeted surface.

In the event any parts are missing from this package, send your name, address, telephone number, and a description of the missing part(s) to: PARTS, Box 1420, Missoula, MT 59806 or call: 1-800-769-5693 or FAX 1-800-445-5281.

CAUTION: On assemblies requiring glue, make sure the unit is assembled correctly before gluing. Once this unit is assembled with glue, the manufacturer will not be responsible for damaged parts. Keep a damp cloth or sponge handy to wipe off excess glue.

To care for this furniture, simply wipe with a cloth dampened with glass cleaner containing ammonia-D.

PARTS DIAGRAM

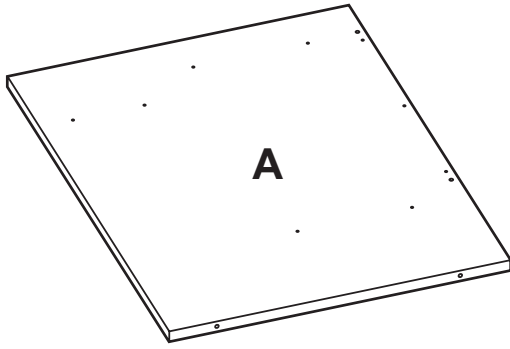

Left-PA3632	01102541	1 ea.
Left-PA3639	01102641	1 ea.

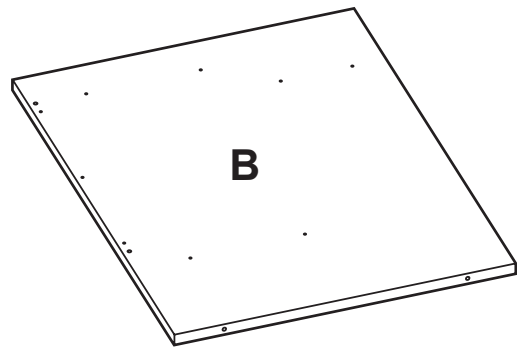

Right Side-PA3632	01102541	1 ea.
Right Side-PA3639	01102641	1 ea.

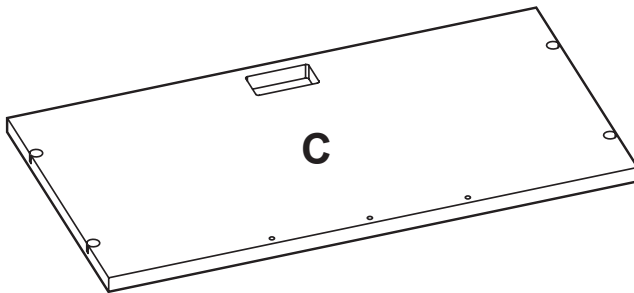

Top	01102501	1 ea.
-----	----------	-------

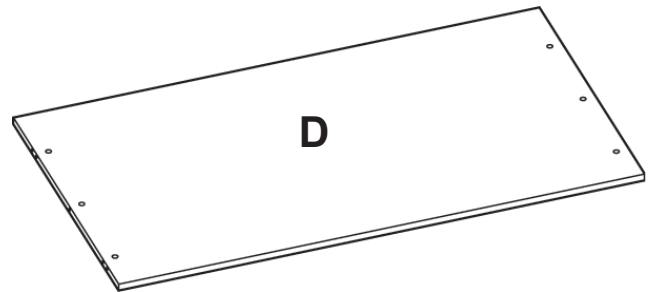

Back	01102552	1 ea.
------	----------	-------

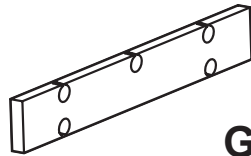

Center Support	01012590	1 ea.
----------------	----------	-------

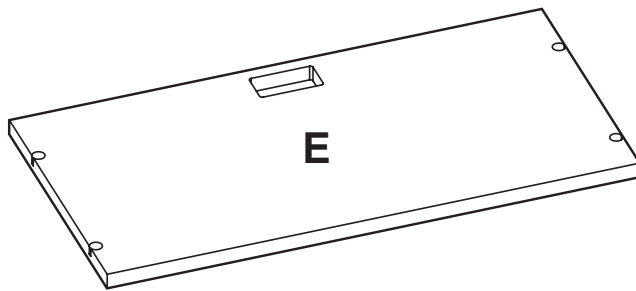

Storage Shelf	01102532	1 ea.
---------------	----------	-------

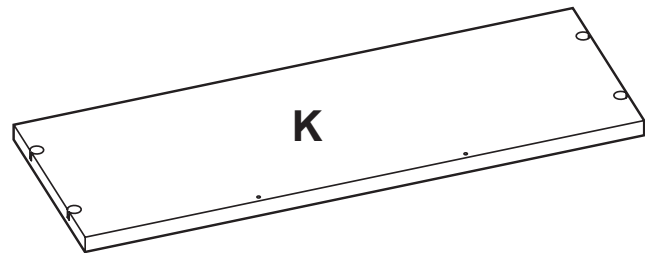

Keyboard Shelf	01102528	1 ea.
----------------	----------	-------

HARDWARE



H1	Rafx Cam	909909	12 ea.
----	----------	--------	--------



H2	Rafx Flush Cam	909834	9 ea.
----	----------------	--------	-------



H3	Leveler Insert	274650	4 ea.
----	----------------	--------	-------



H4	Leveler	300870	4 ea.
----	---------	--------	-------



H5	Rafx Bolt	909925	21 ea.
----	-----------	--------	--------

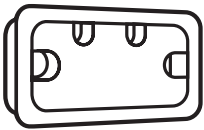

H9	Grommet	286580	2 ea.
----	---------	--------	-------

Insert the Rafx Cams into the appropriate holes. The flat edge of the cam should be facing the edge of the panel.

Slide Rafx Cams of the panel to be attached onto the corresponding posts.

When screwing post into hole, **Do Not** over tighten. Screw post down until bottom face of post flange just touches board surface.

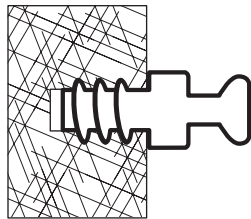

Using a #3 Phillips screwdriver, turn the rotating portion of the Rafx Cam a 1/2 turn clockwise to secure. **IMPORTANT!** Do not exceed 1/2 turn when tightening cams. Turn 1/2 turn counterclockwise to disassemble and remove panel.

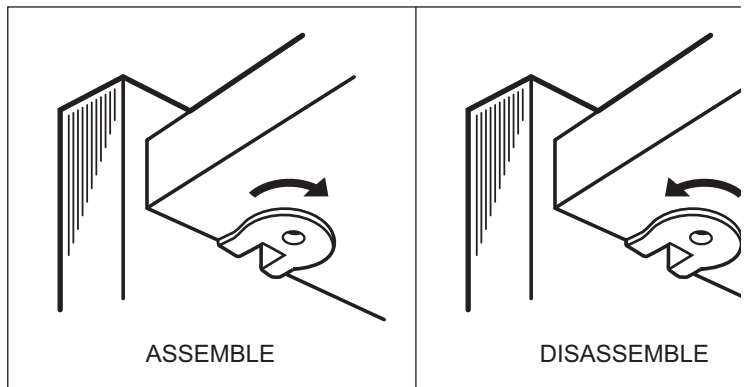
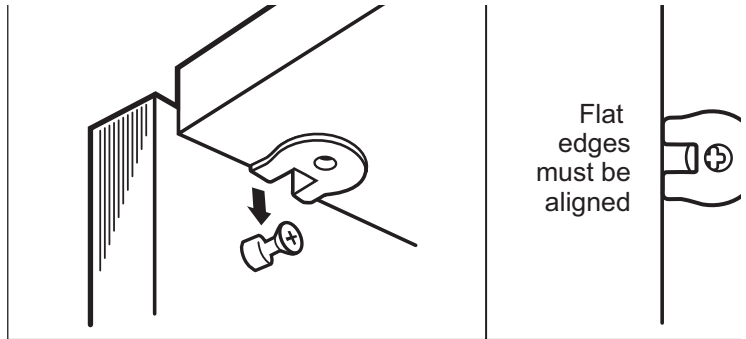

#1

Place the Top (C), Storage Shelf (E), and Keyboard Shelf (K) on a clean, carpeted surface as shown. Tap in Rafix Cams (H1) into each panel where indicated with the flat edges aligned.

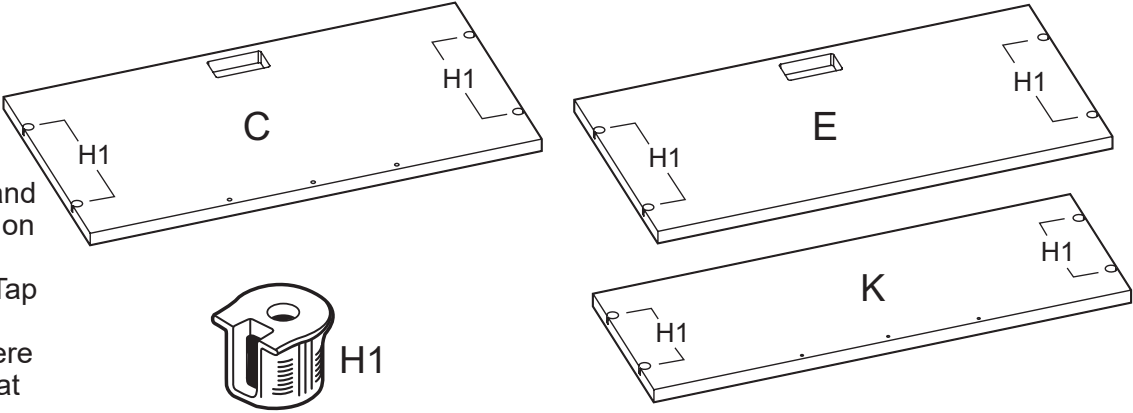

#2

Insert two rafix bolts (H5) into the Top (C). Insert flush rafix cams (H2) in the center support (G) and place on rafix bolts and turn to secure.

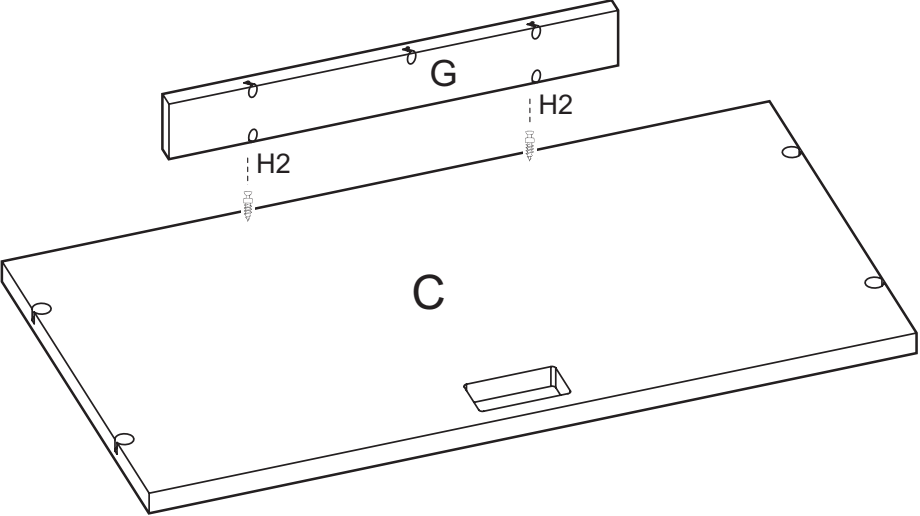

#3

Screw nine rafx Bolts (H5) into the Left Side (A) and Right Side (B) where indicated.

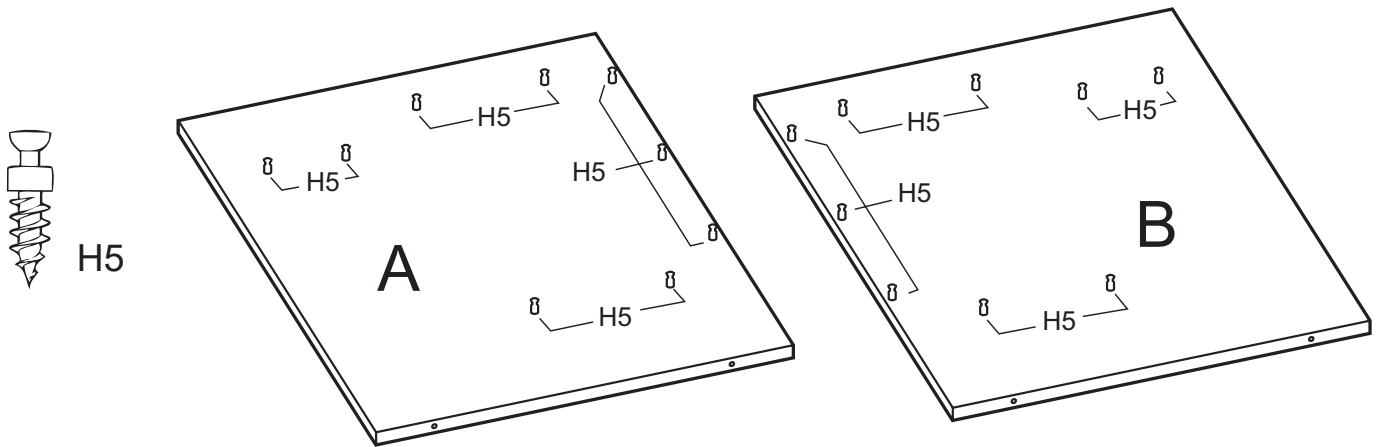

#4

Insert Leveler Inserts (H3) into the holes in the bottom edges of Left Side (A) and Right Side (B) and tap into place. Screw the Levelers (H4) into the Leveler Inserts.

Adjust the Levelers when the assembled unit is in place.

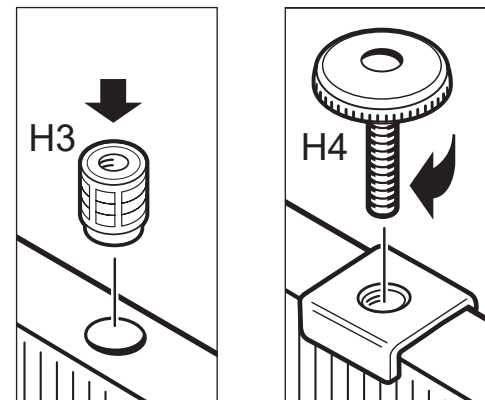

#5

Insert six Rafix Cams (H1) into the Back (D)

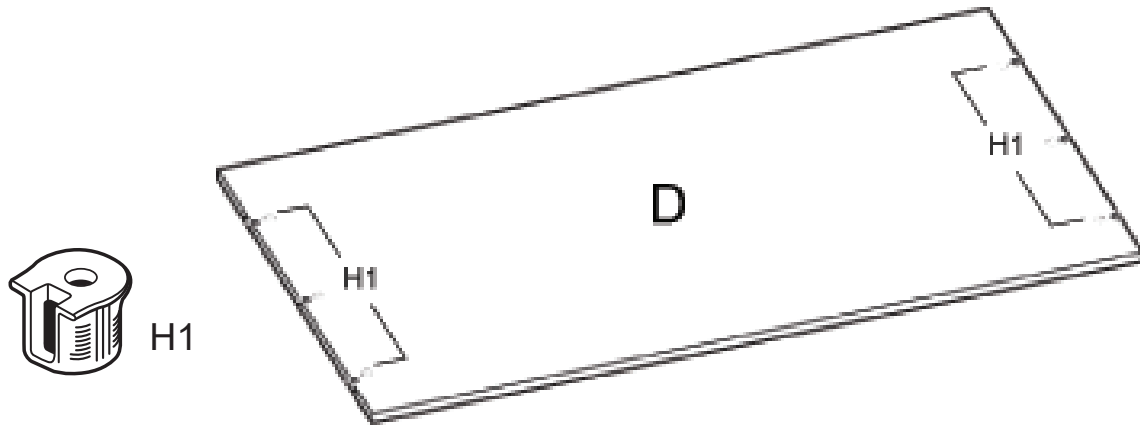

#6

Place the Left Side (A) with the bolts facing up as shown. Position the Back (D) onto the Left Side (A) and turn the cams (H1) to secure.

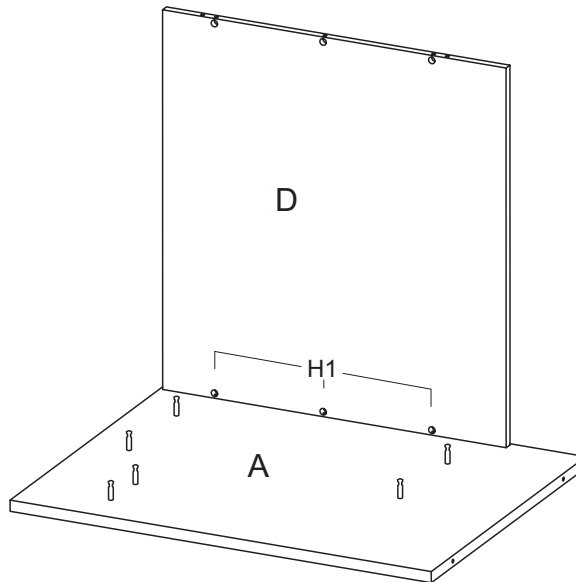

#7

Position the Top (C) and Center Support Panel (G) assembly onto the Left Side (A) and turn Rafix Cams (H1) clockwise to secure.

Do not exceed 1/2 turn when tightening.

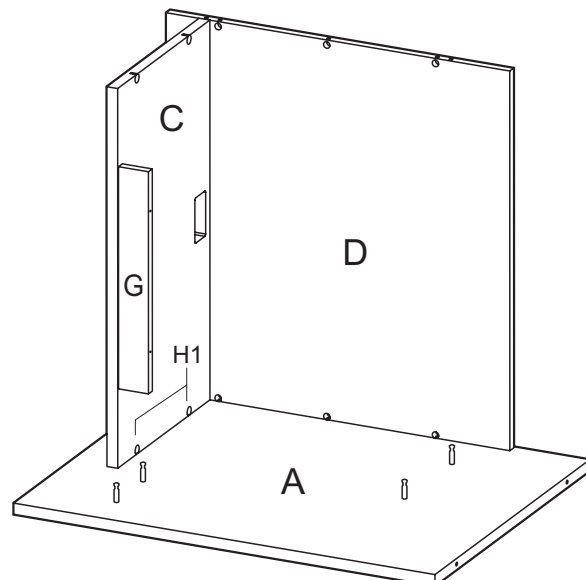

#8

Screw in 3 rafix bolts (H5) into Keyboard Shelf (K)

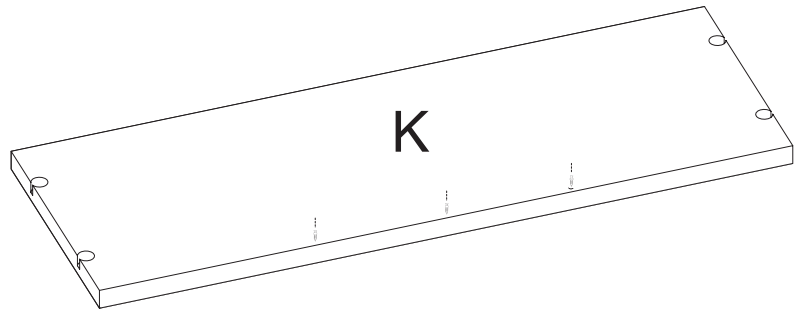

#9

Position the Keyboard Shelf (K) into the Left Side (A) and turn Rafix Cams (H1) to secure.

Secure the Keyboard Shelf (K) to the Center Support Panel (G) by turning cams to secure.

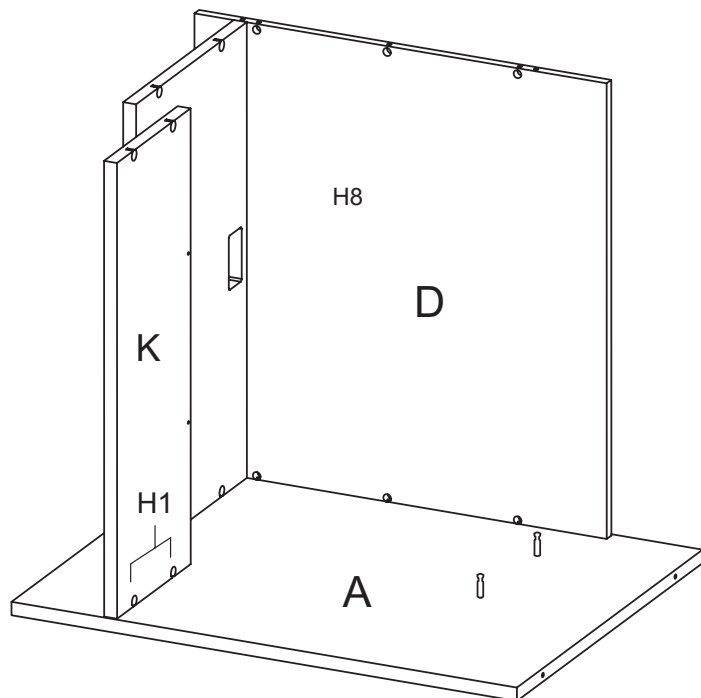

#10

Position the Storage Shelf (E) onto the Left Side (A) and turn Rafx Cams (H1) clockwise to secure.

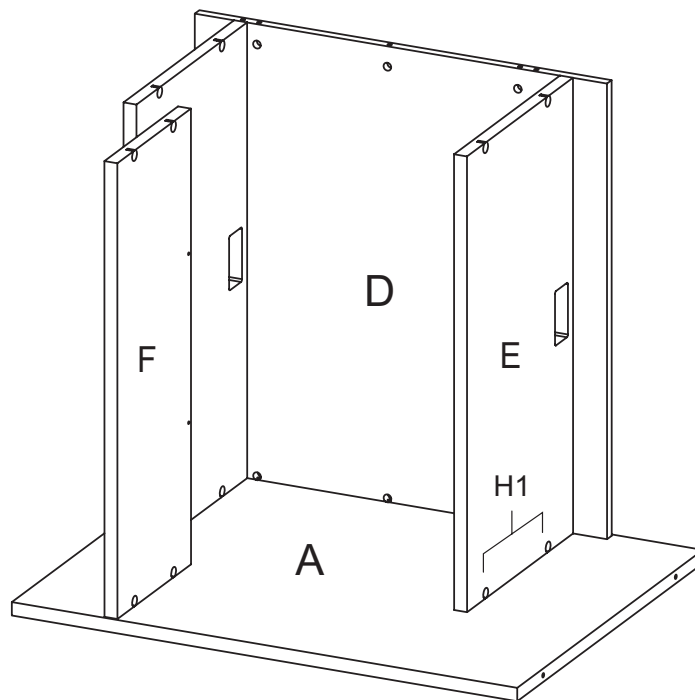

#11

Position the bolts of the Right Side (B) onto the unit and turn cams to lock in place.

There are nine Rafx Cams to tighten

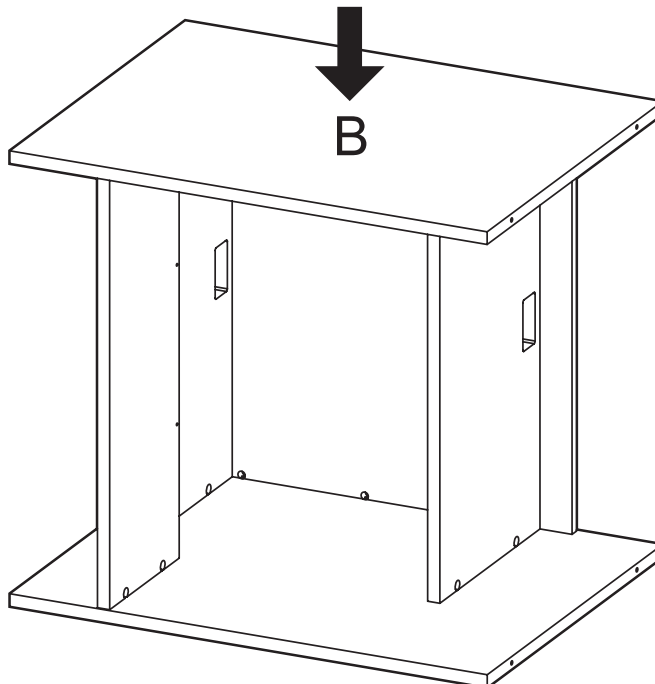

#12

With the help of another person, turn the unit upright.

Insert Grommets (H9) into the top (C) and the Storage Shelf (E).

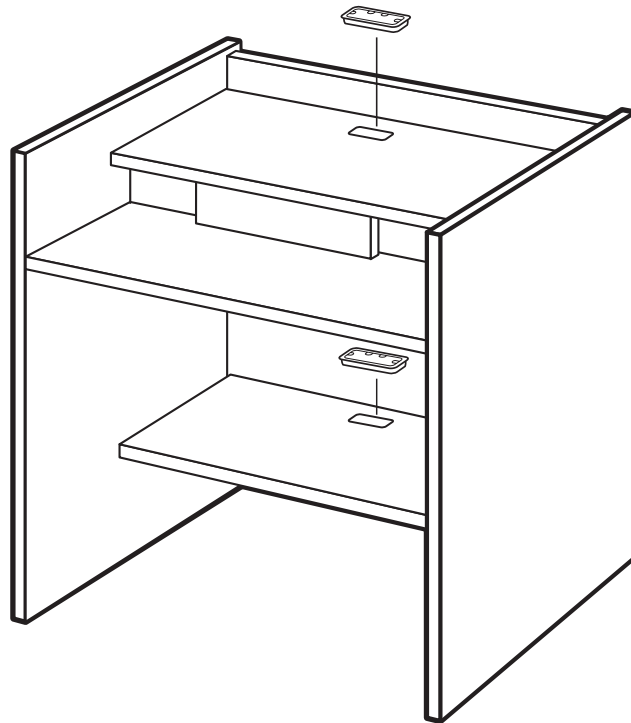
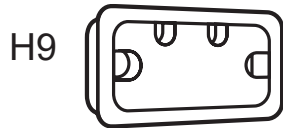

Your Glacire Patron Access Station is now fully assembled and ready for use.