

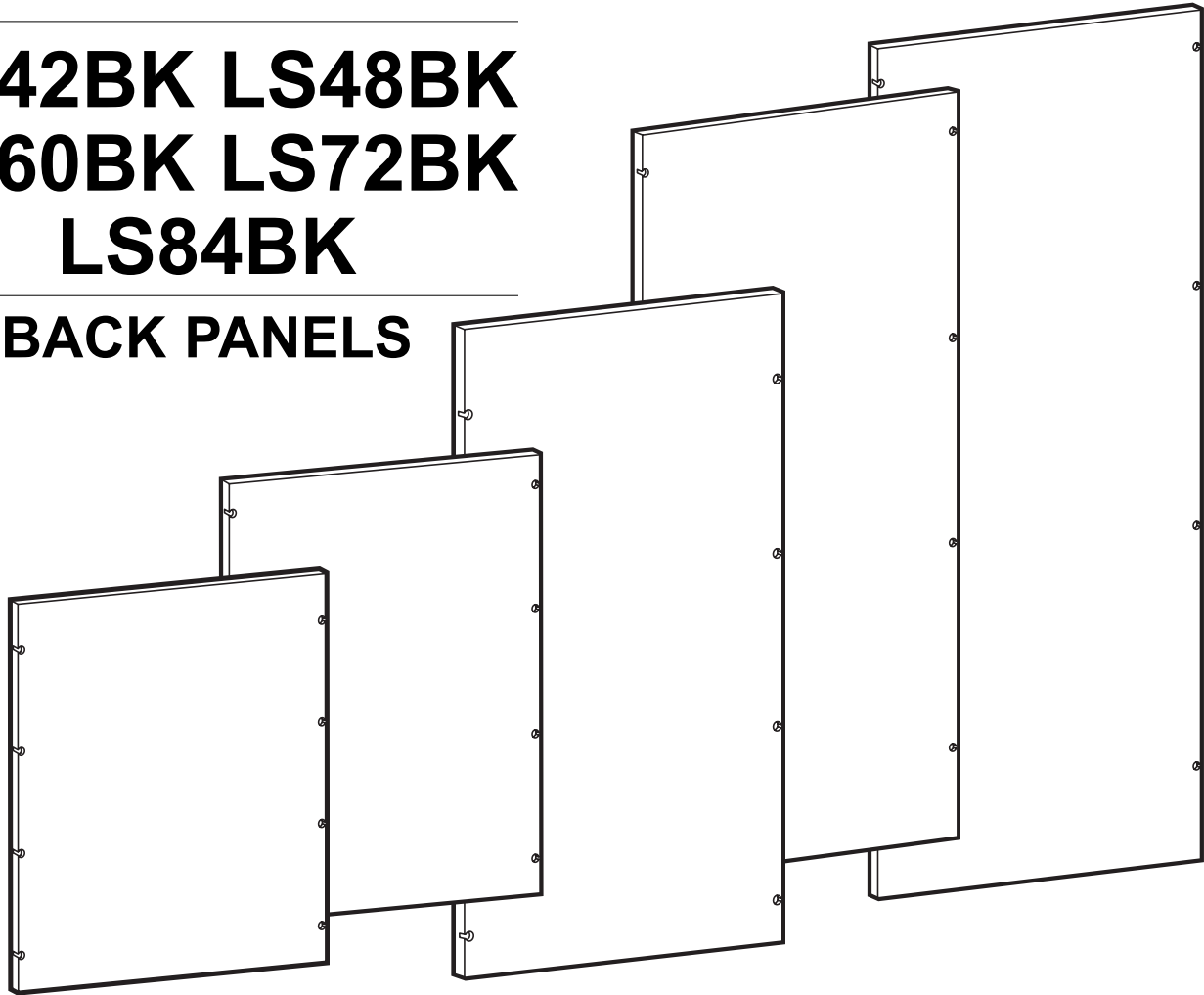

BY  IRONWOOD

LS42BK LS48BK LS60BK LS72BK LS84BK

BACK PANELS



IMPORTANT!

Assembly may require the assistance of another person.

Before you begin assembly:

READ THE DIRECTIONS all the way through one time. This will speed up the process and help you understand the sequence of steps.

COUNT THE PARTS AND HARDWARE before assembly. This ensures you have received all necessary parts before you begin.

TOOLS: You may need a Phillips head screwdriver, a medium slotted screwdriver or a plastic mallet. To protect your new furniture from damage during assembly, it is recommended to work on a carpeted surface.

In the event any parts are missing from this package, send your name, address, telephone number, and a description of the missing part(s) to: PARTS, Box 1420, Missoula, MT 59806 or call: 1-800-769-5693 or FAX 1-800-445-5281.

CAUTION: On assemblies requiring glue, make sure the unit is assembled correctly before gluing. Once this unit is assembled with glue, the manufacturer will not be responsible for damaged parts. Keep a damp cloth or sponge handy to wipe off excess glue.

To care for this furniture, simply wipe with a cloth dampened with glass cleaner containing ammonia-D.



H8	Rafix Cam Housing	909915	8 ea.
----	-------------------	--------	-------



H9	Rafix Bolt	909923	8 ea.
----	------------	--------	-------

Using the Rafix System:

Insert the Rafix Cams into the appropriate holes. The flat edge of the cam should be facing the edge of the panel.

Slide Rafix Cams of the panel to be attached onto the corresponding posts.

When screwing post into hole, **Do Not** over tighten. Screw post down until bottom face of post flange just touches board surface.

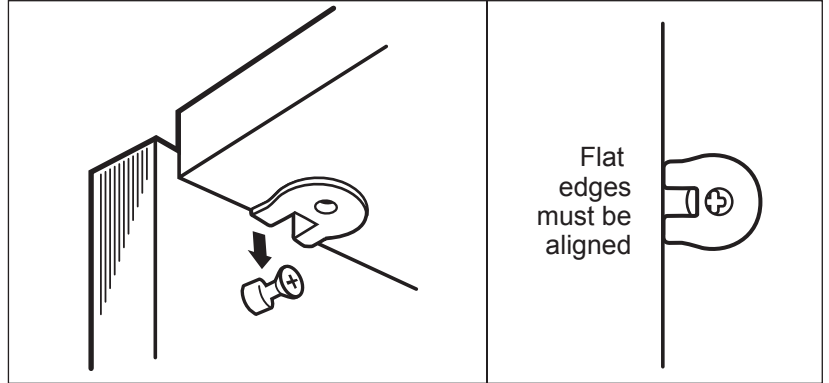
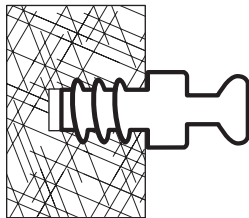

Using a #3 Phillips screwdriver, turn the rotating portion of the Rafix Cam a 1/2 turn clockwise to secure. **IMPORTANT!** Do not exceed 1/2 turn when tightening cams. Turn 1/2 turn counterclockwise to disassemble and remove panel.

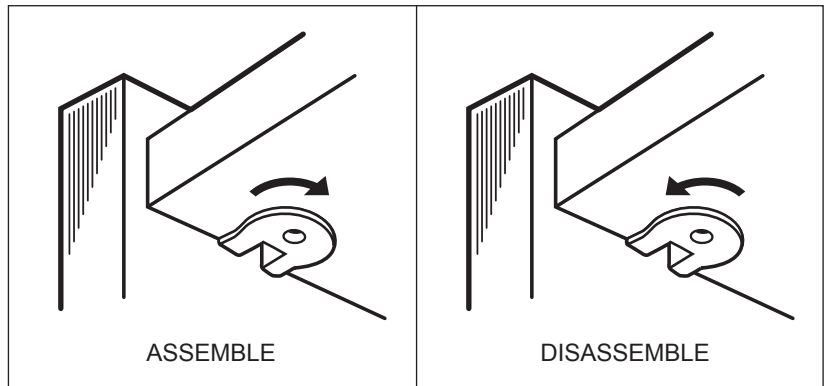

#1

Preparing the Back Panel for installation:

Insert eight Rafix Cams (H8) into the Back (D) with the flat edge facing outwards. Tap until fully seated in place as shown.

IMPORTANT! The flat edge of the Rafix Cam must be aligned with the panel edge. Rafix Cams **cannot** be repositioned after installation.

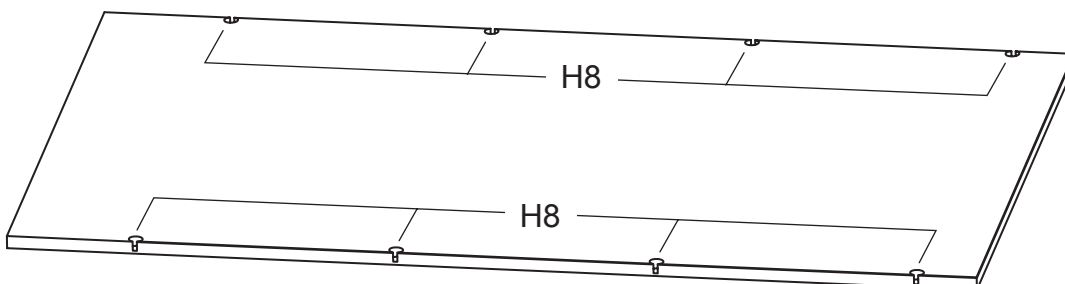

#2

Screw four Rafix Bolts (H9) into each side panel (A,B) in the pre-drilled holes where indicated.

These will be the larger holes.

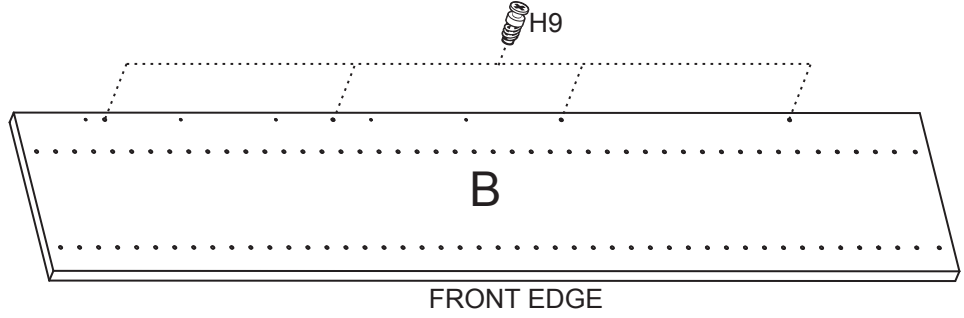
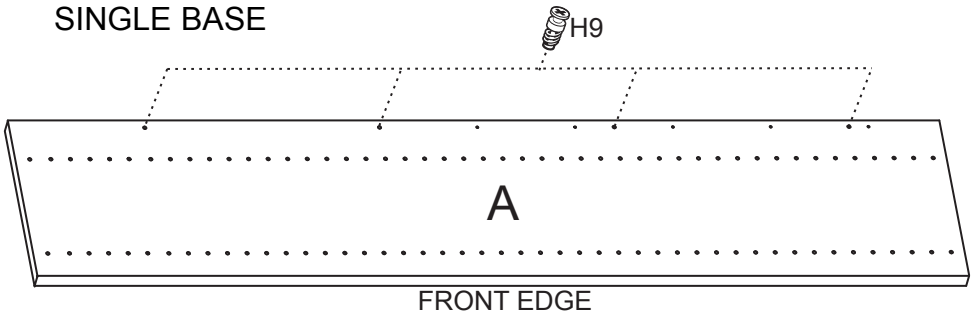

DOUBLE BASE

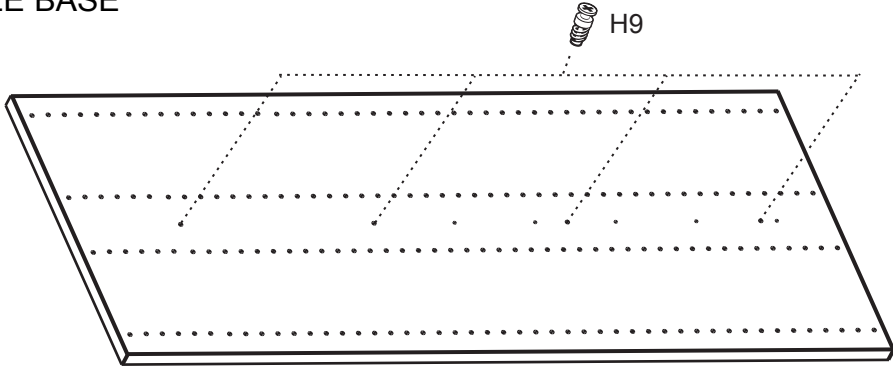

#3

Set the Back Panel onto the Rafix Bolts, and tighten the Rafix Cams 1/2 turn clockwise.

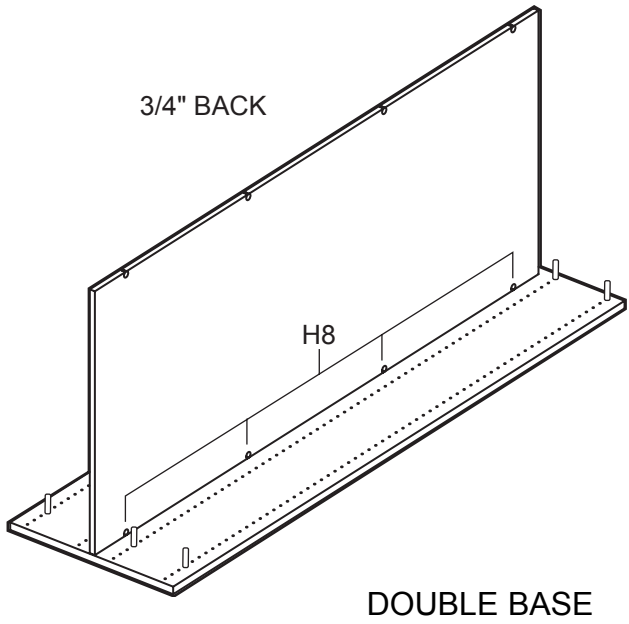
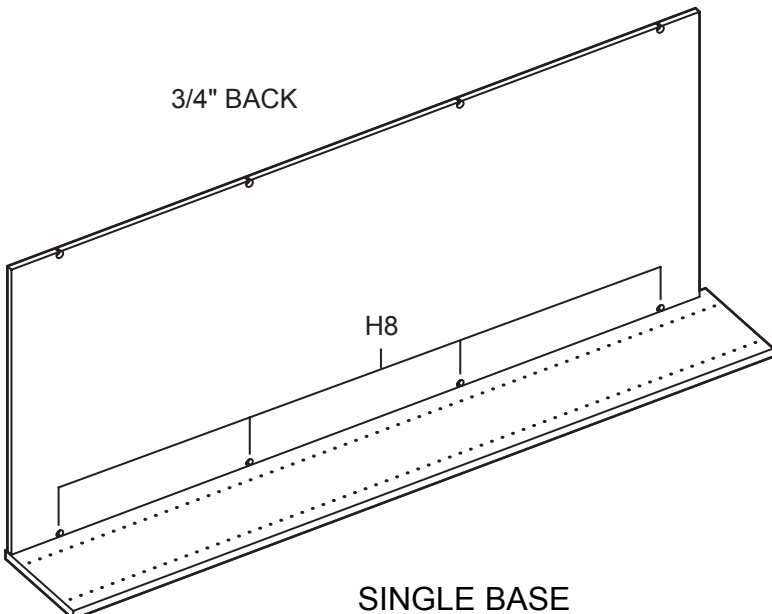

#4

With the assistance of another person, set the Side/Back assembly upright.

Set the remaining Side Panel so that the Rafix Bolts are seated in the Rafix Cams in the Back Panel. Tighten the Rafix Cams 1/2 turn clockwise.

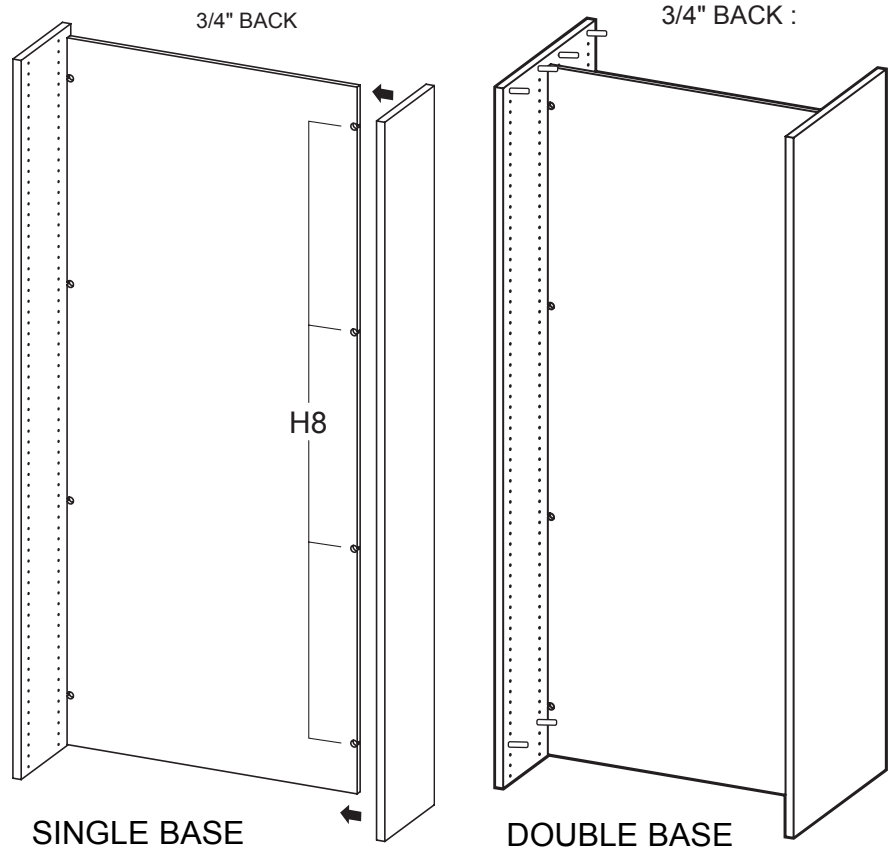

#5

Attach the Top Panel and the Bottom (Fixed) Shelf according to the instructions you received with your Shelving Unit.

