



BY  **IRONWOOD**

---

# GLT

---

## LIBRARY TABLES

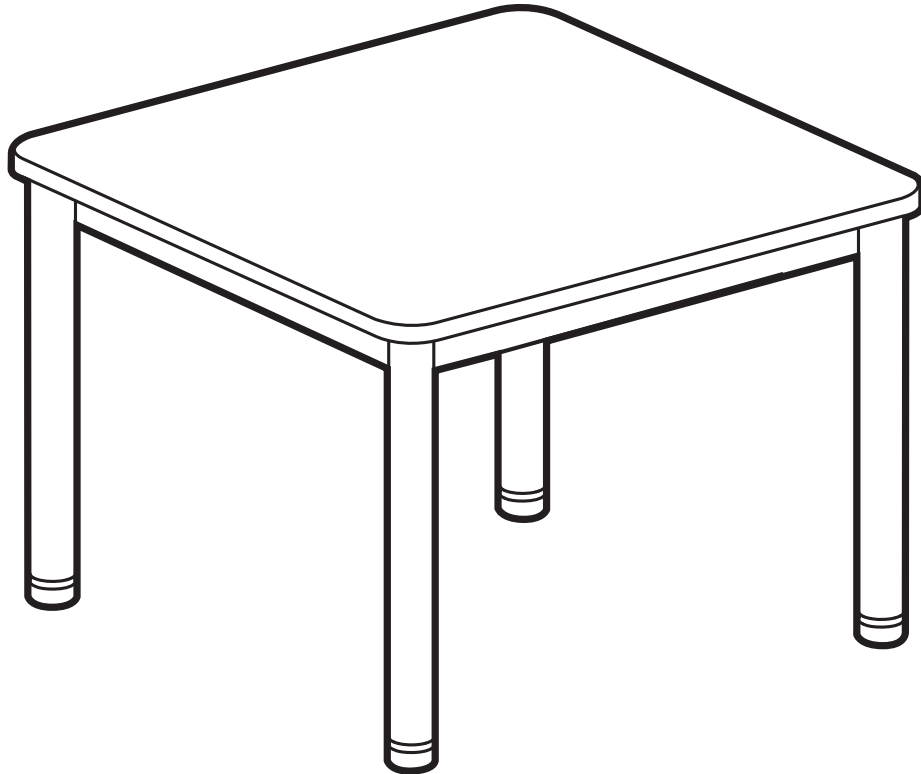

### **IMPORTANT!**

**Assembly may require the assistance of another person.**

**Before you begin assembly:**

**READ THE DIRECTIONS** all the way through one time. This will speed up the process and help you understand the sequence of steps.

**COUNT THE PARTS AND HARDWARE** before assembly. This ensures you have received all necessary parts before you begin.

**TOOLS:** You will need a 1/2" wrench. To protect your new furniture from damage during assembly, it is recommended to work on a carpeted surface.

In the event any parts are missing from this package, send your name, address, telephone number, and a description of the missing part(s) to: **PARTS, Box 1420, Missoula, MT 59806** or call: **1-800-769-5693** or **FAX 1-800-445-5281**.

**CAUTION:** On assemblies requiring glue, make sure the unit is assembled correctly before gluing. Once this unit is assembled with glue, the manufacturer will not be responsible for damaged parts. Keep a damp cloth or sponge handy to wipe off excess glue.

To care for this furniture, simply wipe with a cloth dampened with glass cleaner containing ammonia-D.

# PARTS DIAGRAM

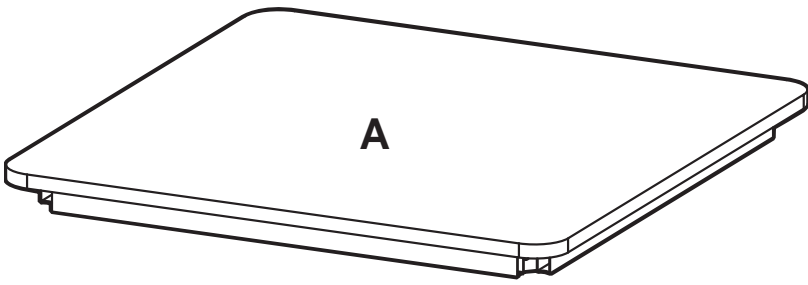
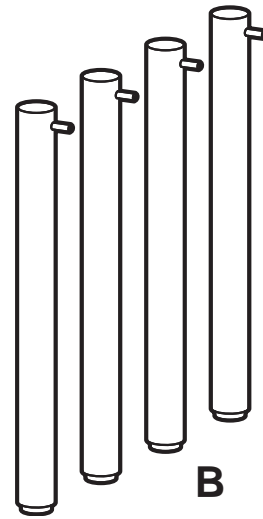
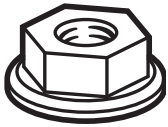

Table Top	1 ea.
-----------	-------



Legs	4 ea.
------	-------



Lock Nut	H2390	4 ea.
----------	-------	-------

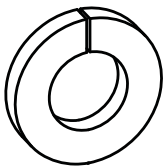

Lock Washer	H2586	4 ea.
-------------	-------	-------

## #1

Place the Table Top (A) on a clean, carpeted surface or foam padding as shown.

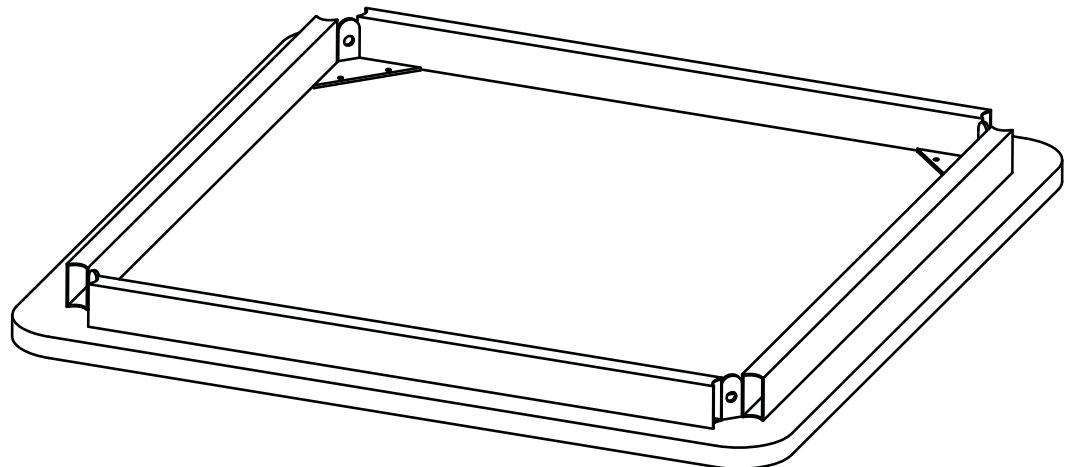

**#2**

Remove the protective cover from the leg bolt. Insert the four Legs (B) into the frame of the Table Top (A) as shown.

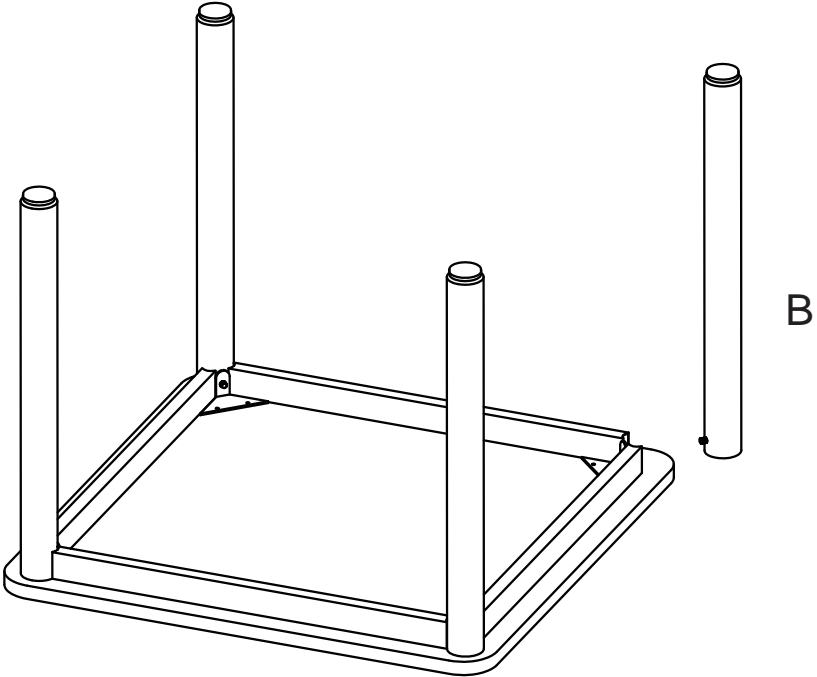

**#3**

Secure each Leg (B) in place with a Lock Washer and Nut (C) as shown.

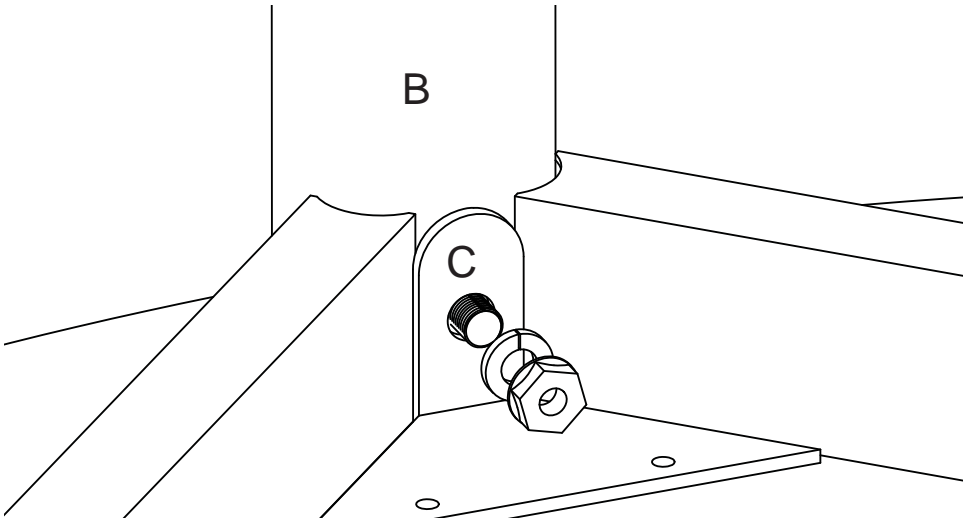

**#4**

With the assistance of another person, turn the table upright. Adjust the levelers of the Legs (B) when the Library Table is in place.

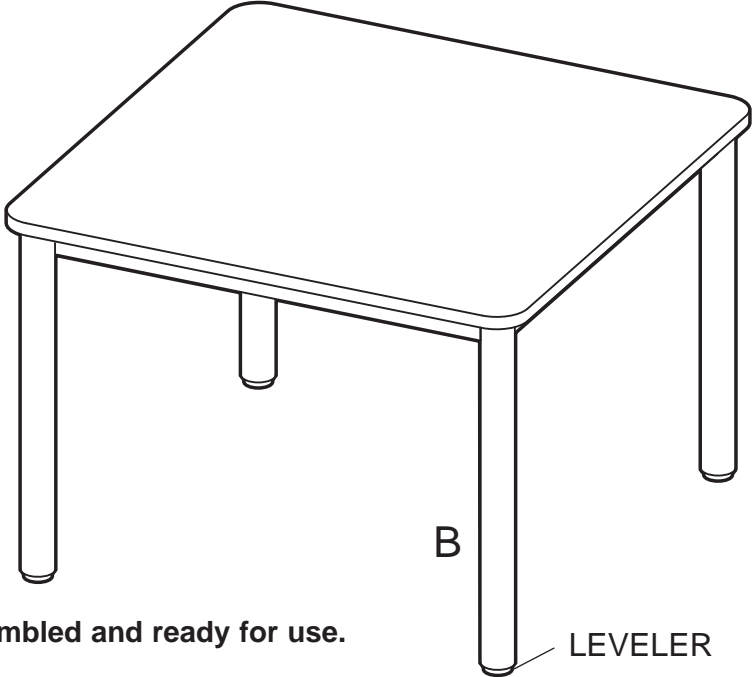

Your Glacier Table is now assembled and ready for use.