



BY  **IRONWOOD**

## CIRCULATION DESK

# CDTW32 CDTW39

## TOWER STATION

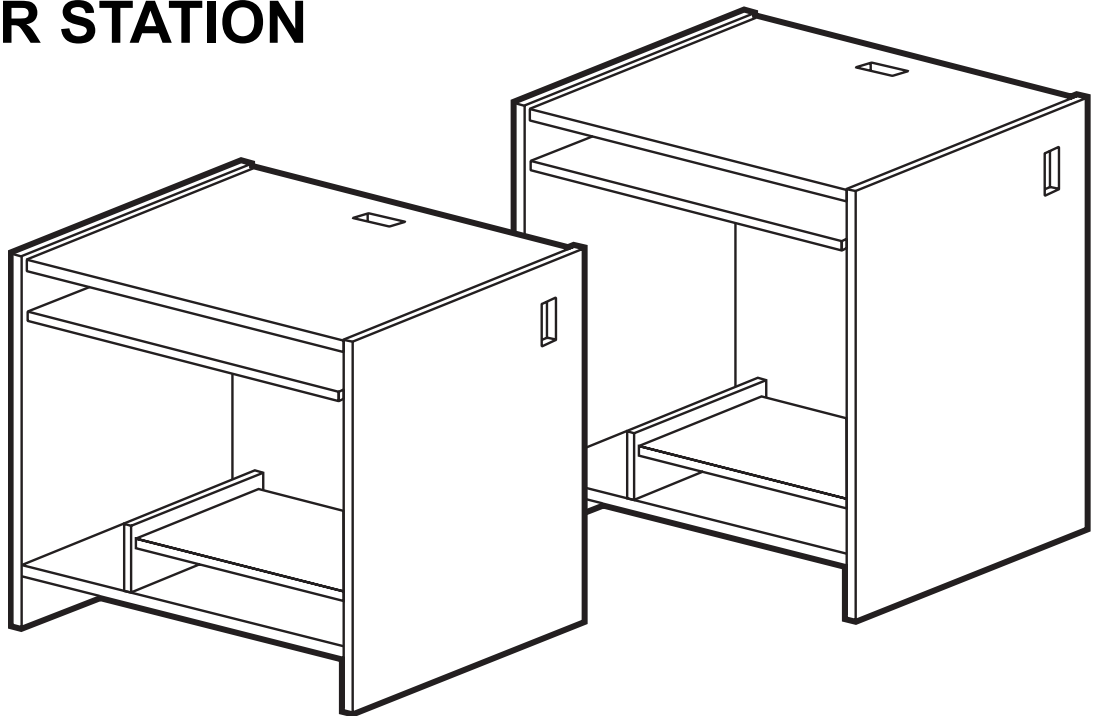

### IMPORTANT!

Assembly may require the assistance of another person.

Before you begin assembly:

**READ THE DIRECTIONS** all the way through one time. This will speed up the process and help you understand the sequence of steps.

**COUNT THE PARTS AND HARDWARE** before assembly. This ensures you have received all necessary parts before you begin.

**TOOLS:** You may need a Phillips head screwdriver, a medium slotted screwdriver or a plastic mallet. To protect your new furniture from damage during assembly, it is recommended to work on a carpeted surface.

In the event any parts are missing from this package, send your name, address, telephone number, and a description of the missing part(s) to: **PARTS, Box 1420, Missoula, MT 59806** or call: **1-800-769-5693** or **FAX 1-800-445-5281**.

**CAUTION:** On assemblies requiring glue, make sure the unit is assembled correctly before gluing. Once this unit is assembled with glue, the manufacturer will not be responsible for damaged parts. Keep a damp cloth or sponge handy to wipe off excess glue.

To care for this furniture, simply wipe with a cloth dampened with glass cleaner containing ammonia-D.

# PARTS DIAGRAM

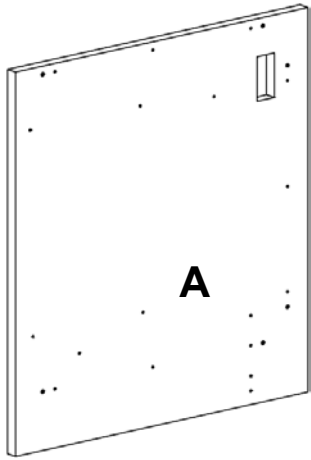

Left Side - CDTW	01050641	1 ea.
Left Side - CDTW39	01050741	1 ea.

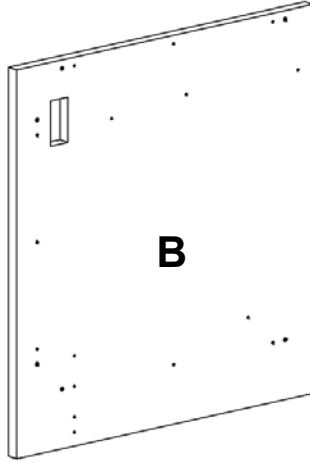

Right Side - CDTW	01050641	1 ea.
Right Side - CDTW39	01050741	1 ea.

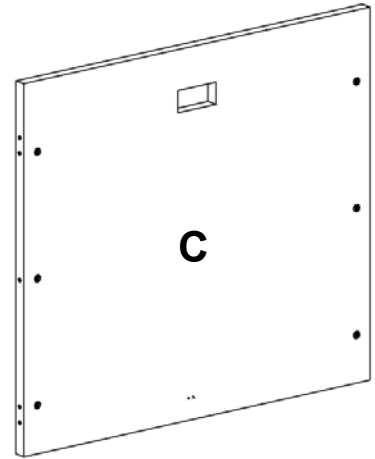

Top	01050601	1 ea.
-----	----------	-------

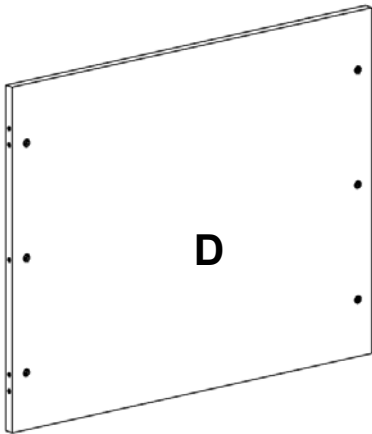

Back - CDTW	01050652	1 ea.
Back - CDTW39	01050752	1 ea.

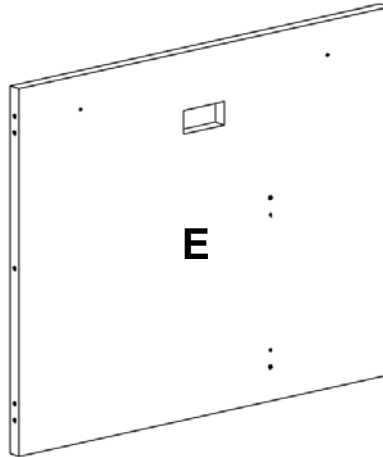

Bottom	01050611	1 ea.
--------	----------	-------

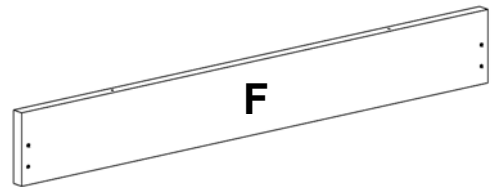

Toeboard	01050172	1 ea.
----------	----------	-------

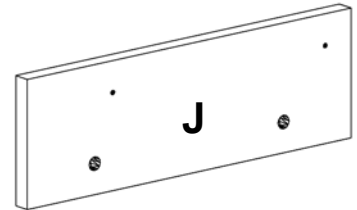

Divider	01050644	1 ea.
---------	----------	-------

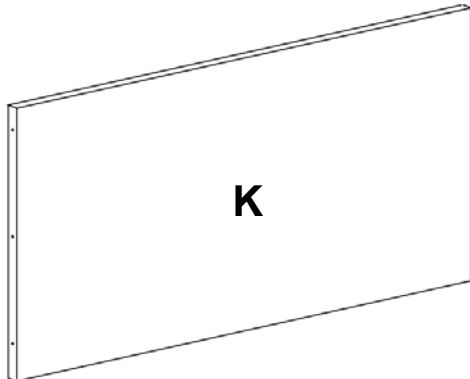

Keyboard Shelf	01050641	1 ea.
----------------	----------	-------

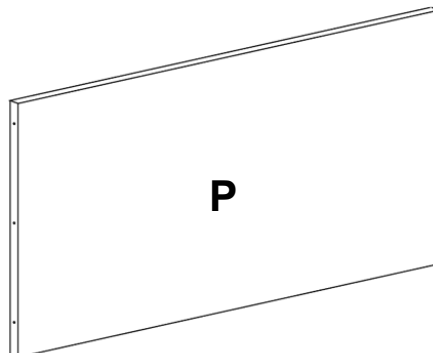

Printer Shelf	01050629	1 ea.
---------------	----------	-------

# HARDWARE



H1	Minifix Cam	909810	20 ea.
----	-------------	--------	--------



H2	Leveler Insert	274650	4 ea.
----	----------------	--------	-------

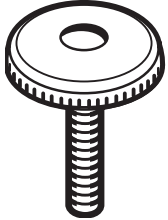

H3	Leveler	300870	4 ea.
----	---------	--------	-------



H4	Dowel	195000	14 ea.
----	-------	--------	--------



H5	Minifix Bolt	909834	20 ea.
----	--------------	--------	--------



H6	Varianta Screw	988060	16 ea.
----	----------------	--------	--------



H8	Confirmat Screw	950100	3 ea.
----	-----------------	--------	-------

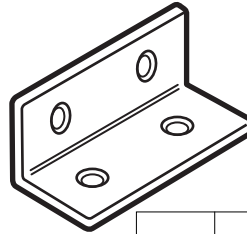

H7	Angle Bracket	401170	2 ea.
----	---------------	--------	-------

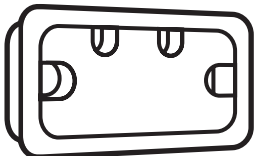

H10	Grommet	286580	4 ea.
-----	---------	--------	-------



H9	#8 x 5/8" Panhead Screw	988056	12 ea.
----	----------------------------	--------	--------



H11	Connector Screw	901350	4 ea.
-----	-----------------	--------	-------



H12	Connector Sleeve	950200	4 ea.
-----	------------------	--------	-------



H14	6 x .625 Panhead Screw	901216	2 ea.
-----	---------------------------	--------	-------

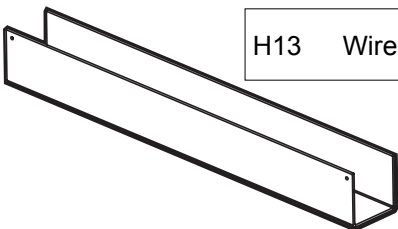

H13	Wire Trough	412990	1 ea.
-----	-------------	--------	-------



S1	Full Extension Slide	490420	2 ea.
----	-------------------------	--------	-------

### Using the Minifix System:

Insert the Minifix Cams into the appropriate holes with the arrow facing outwards as shown.

When screwing post into hole, **Do Not** over tighten. Screw post down until bottom face of post flange just touches board surface.

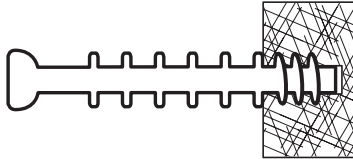

Using the #2 Phillips screwdriver, rotate the Cam Devices a half turn clockwise until snug.

To disassemble, turn the Cam Devices counter-clockwise and remove panels.

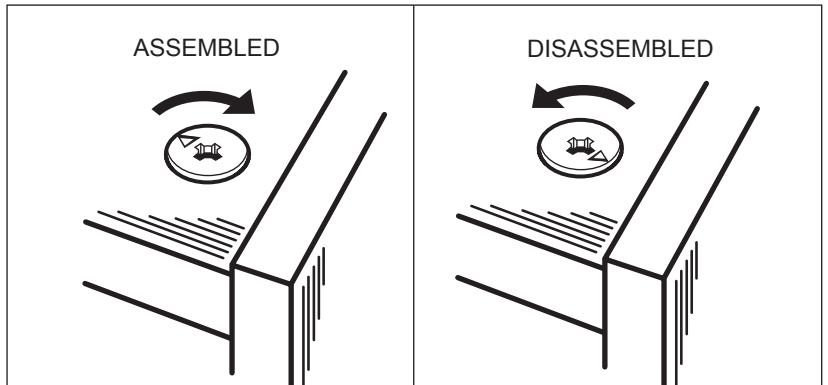
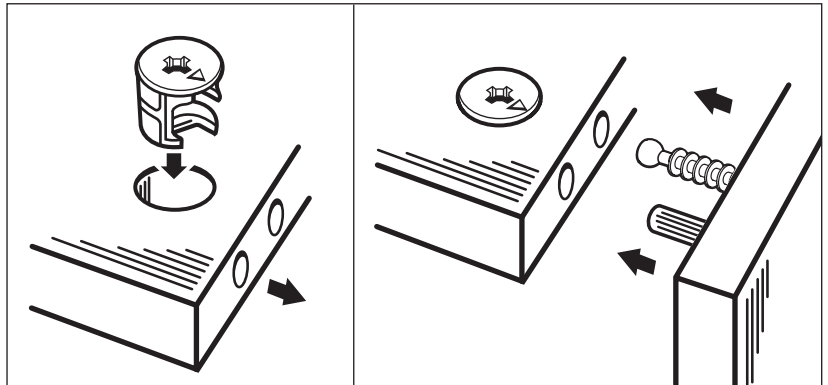

## #1

Insert six Minifix Cams (H1) into the Back (D) with the arrows of the cams facing out.

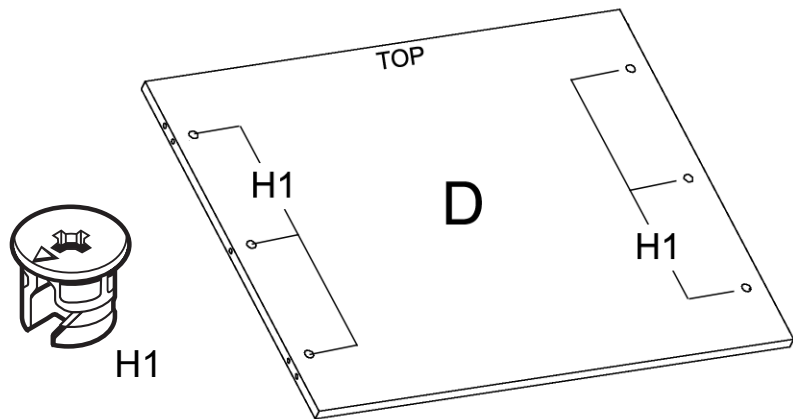

## #2

Place the Left Side (A) and Right Side (B) on a clean, carpeted surface with the pre-drilled holes facing up. Insert the Leveler Inserts (H2) into the holes in the bottom edges of each Side. Using a plastic mallet, tap until flush with the surface. Screw the Levelers (H3) into the Leveler Inserts.

**Adjust Levelers when the assembled unit is in place.**

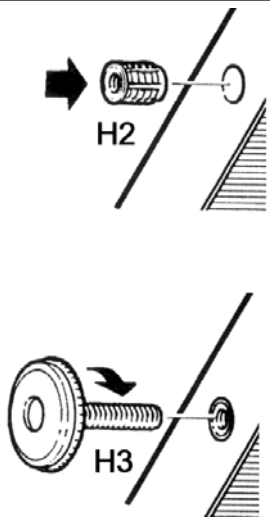

# #3

Screw nine Minifix Bolts (H5) each and insert six Dowels (H4) each into the Left Side (A) and Right Side (B) where indicated.

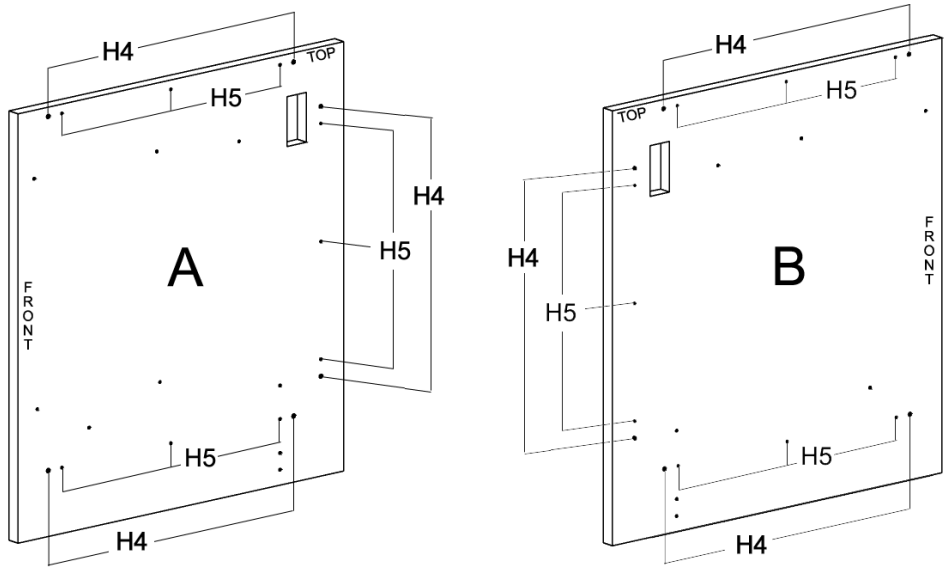
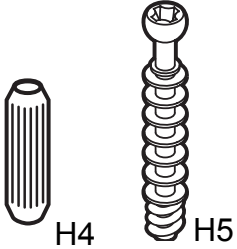

You must disassemble the Full Extension Slides before installing them on the Side Panels (A & B) and the Divider (J). The Full Extension Slides (S1) consist of the main slide sections and the channel sections.

To disassemble the slide, extend the slide completely. Push the arm of the locking clip up and pull the channel section forward until disconnected as shown.

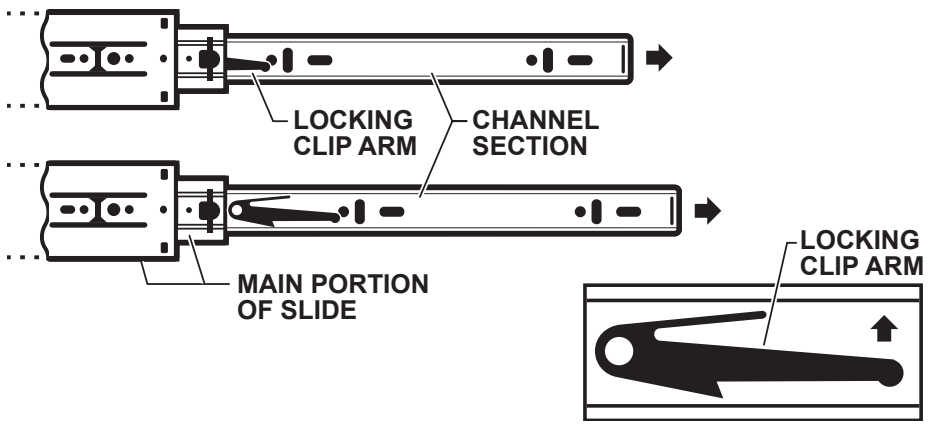

Set the four channel sections aside until Step #19.

# #4

Attach two Full Extension Slides (S1) to Left Side (A) using four Varianta Screws (H6) as shown.

**Note:** It will be necessary to slide the sliding portion forward to access the 1st hole.

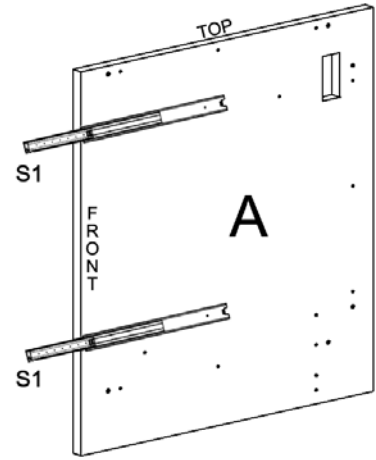
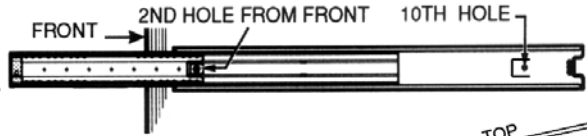

# #5

Attach a Full Extension Slide (S1) to Right Side (B) using two Varianta Screws (H6) as shown.

**Note:** It will be necessary to slide the sliding portion forward to access the 1st hole.

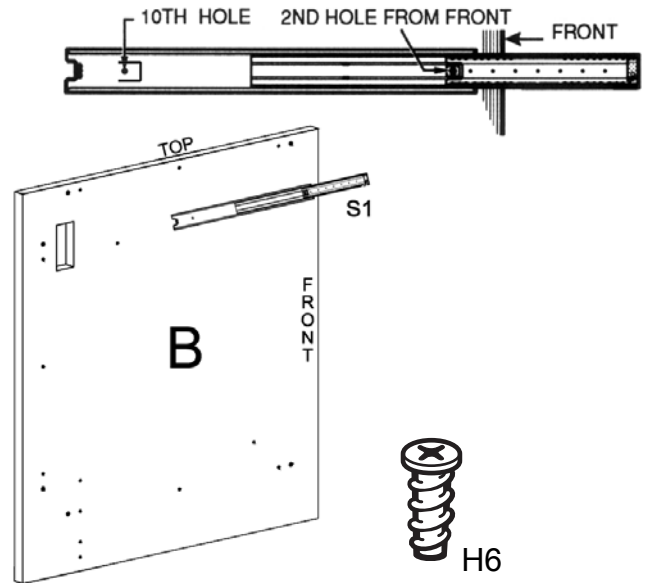

# #6

Position Back (D) onto the Left Side (A) as shown and turn the cams (H1) clockwise to secure.

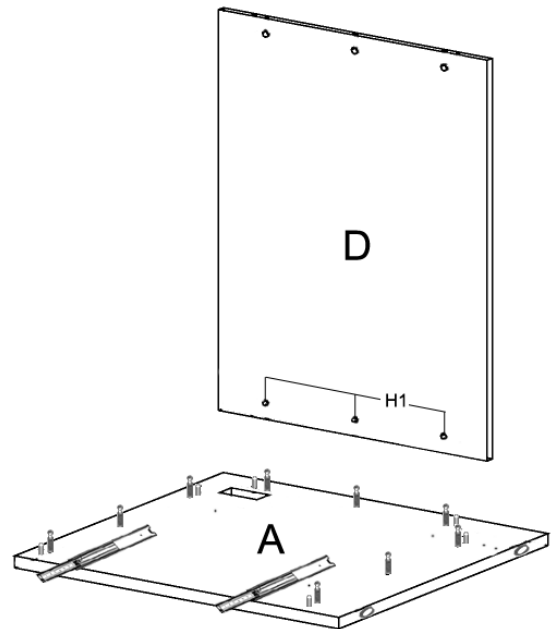

# #7

Insert six Minifix Cams (H1) into the Top (C) with the arrows of the cams facing out.

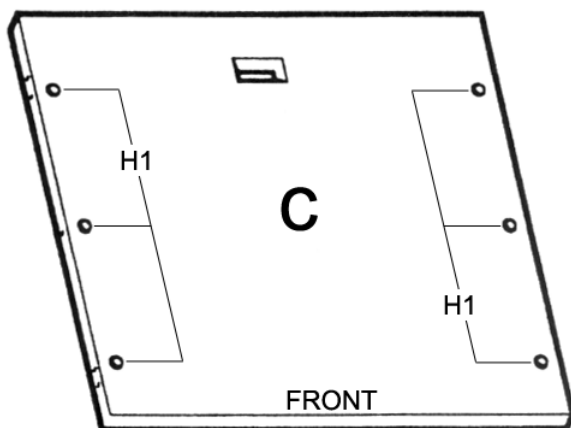

## #8

Peel the paper backing off of the adhesive strip on the Wire Trough (H13). Attach the Wire Trough to the Back of the unit and secure in place by driving two Panhead Screws (H14) through the predrilled holes in the Wire Trough.

Position Top (C) onto the Left Side (A) as shown and turn the cams (H1) clockwise to secure.

**Note:** It will be difficult to remove or reposition the wire trough once the Back and Top are joined.

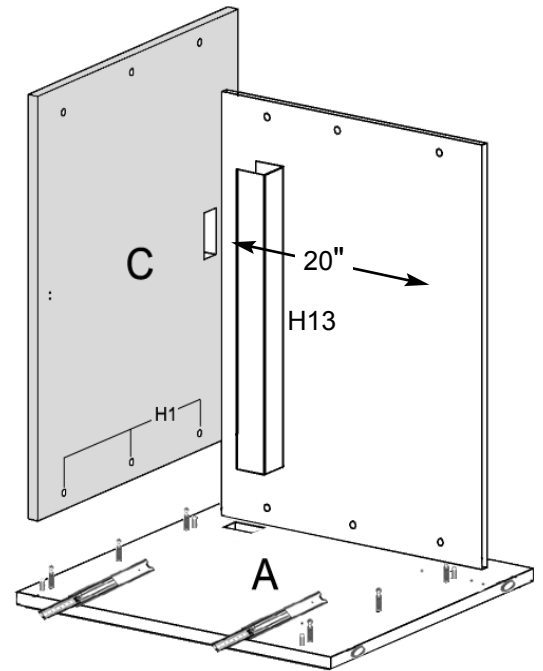
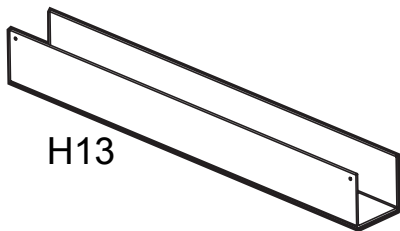

## #9

Position Bottom (E) with the underside side facing up as shown. Insert six Minifix Cams (H1) into the Bottom (E) with the arrows of the cams facing out.

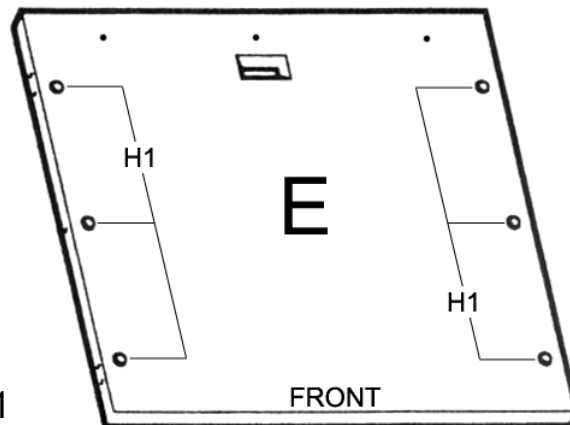

## #10

Flip Bottom (E) over so that the top surface is showing. Screw two Minifix Bolts (H5) and insert two Dowels (H4) in Bottom where indicated.

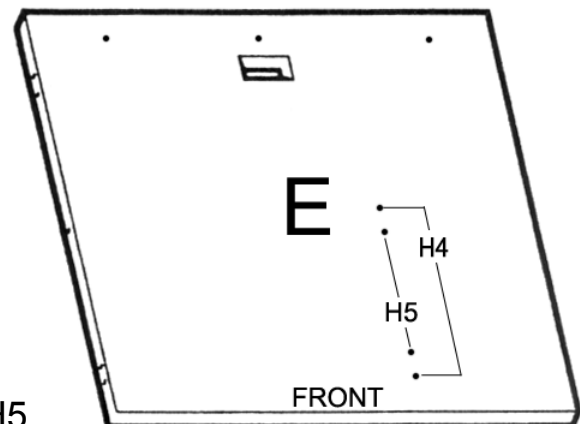
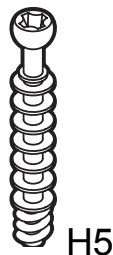

## #11

Secure an Angle Bracket (H7) to each end of the Toeboard (F) using four Varianta Screws (H6).

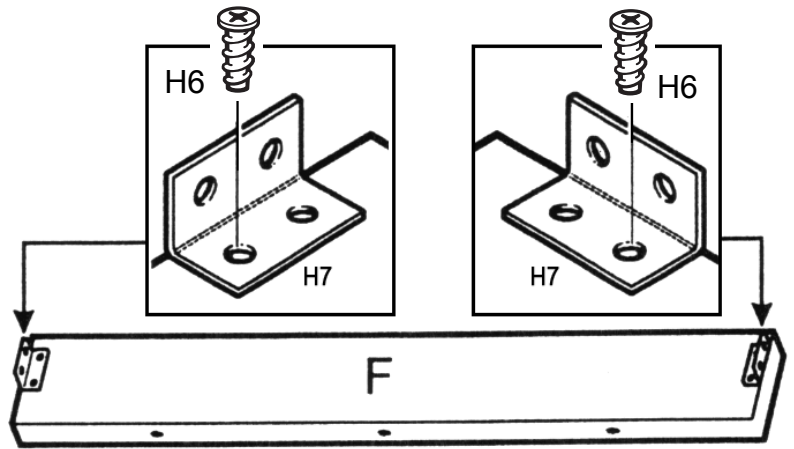

## #12

Attach the Toeboard (F) to the Bottom (E) using three Confirmat Screws (H8) through the pre-drilled holes as shown.

**Note:** The Angle Brackets (H7) should be oriented as shown.

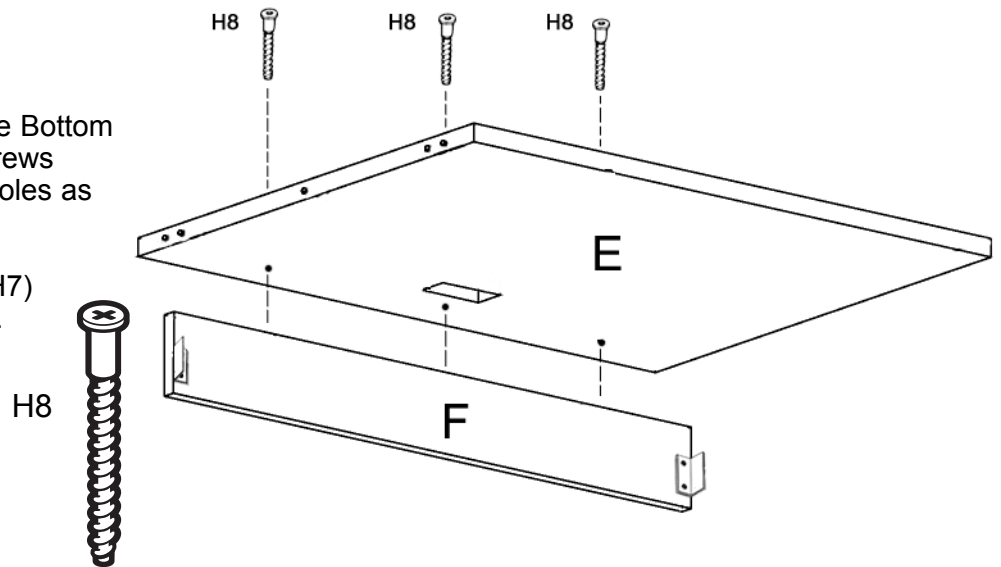

## #13

Insert two Minifix Cams (H1) into the Divider (J) with the arrows of the cams facing out.

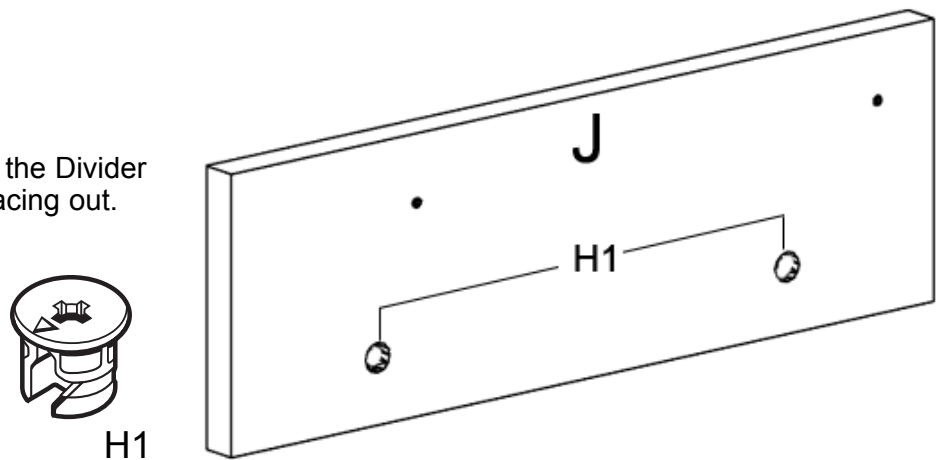



## #14

Attach a Full Extension Slide (S1) to Divider (J) using two Varianta Screws (H6) as shown.

**Note:** It will be necessary to slide the sliding portion forward to access the 1st hole.

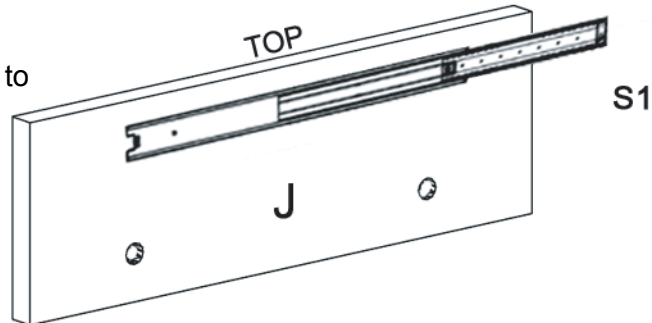
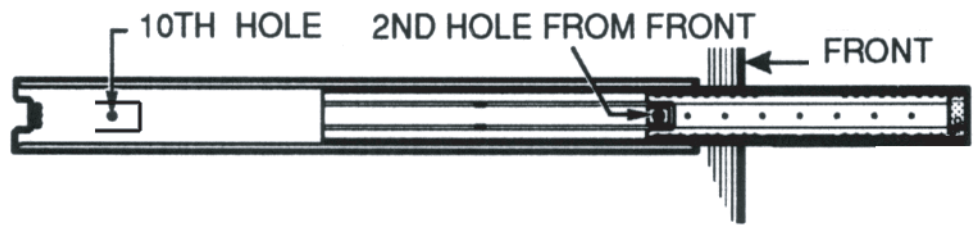

## #15

Position Divider (J) onto the topside of Bottom (E) with front edges aligned as shown and turn the cams (H1) clockwise to secure.

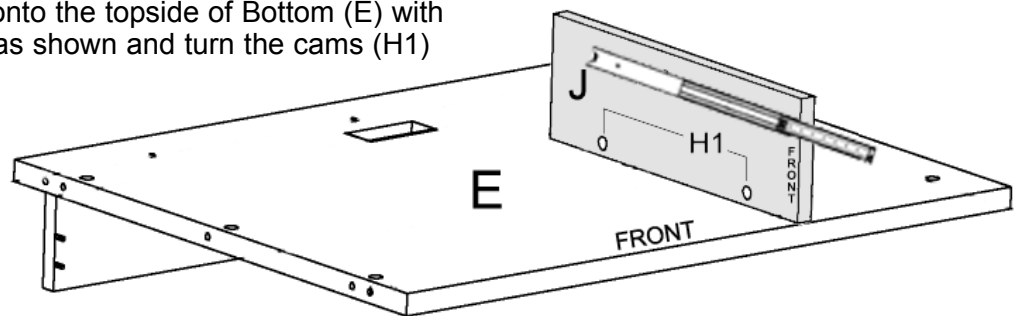

## #16

Position bottom assembly onto the Left Side (A) and turn the cams (H1) clockwise to secure.

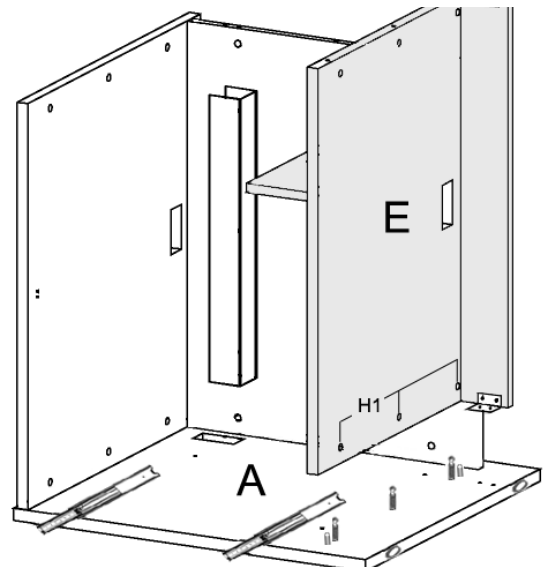

**#17**

Position the bolts and dowels of the Right Side (B) onto the unit and turn cams (H1) clockwise to lock in place.

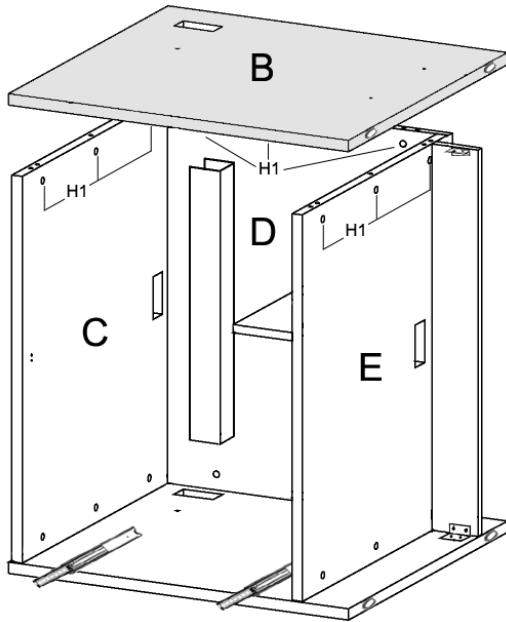

**#18**

Secure the Angle Brackets (H7) of the Toeboard (F) to the Left Side (A) and Right Side (B) using four Varianta Screws (H6).

With the assistance of another person, turn the unit upright.

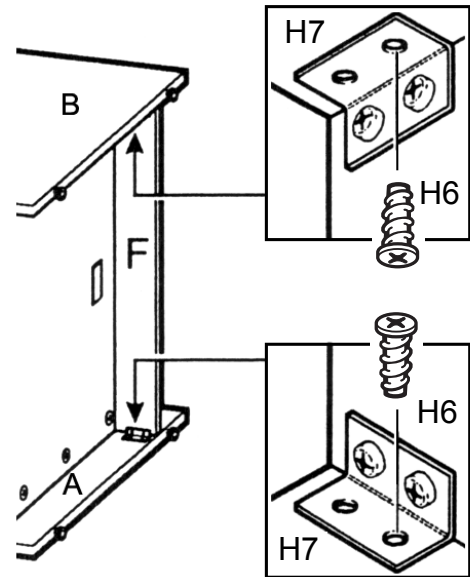

**#19**

Attach two channel portions of the Full Extension Slides (S1) to the right and left side of the Keyboard Shelf (K) using six #8 x 5/8" Panhead Screws (H9) as shown.

**Note:** Make sure that the notch of locking clip is oriented as shown in diagram for proper slide function.

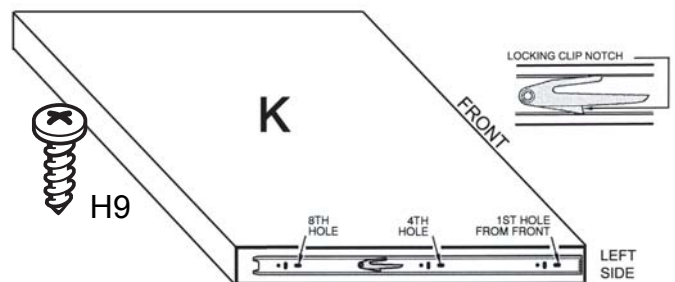
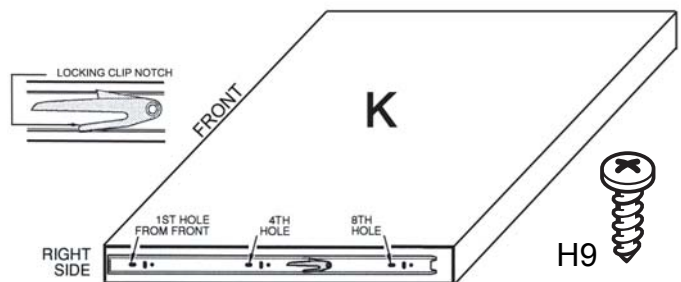

## #20

Attach the two remaining channel portions of the Full Extension Slides (S1) to the right and left side of the Printer Shelf (P) using six #8 x 5/8" Panhead Screws (H9) as shown.

**Note:** Make sure that the notch of locking clip is oriented as shown in diagram for proper slide function.

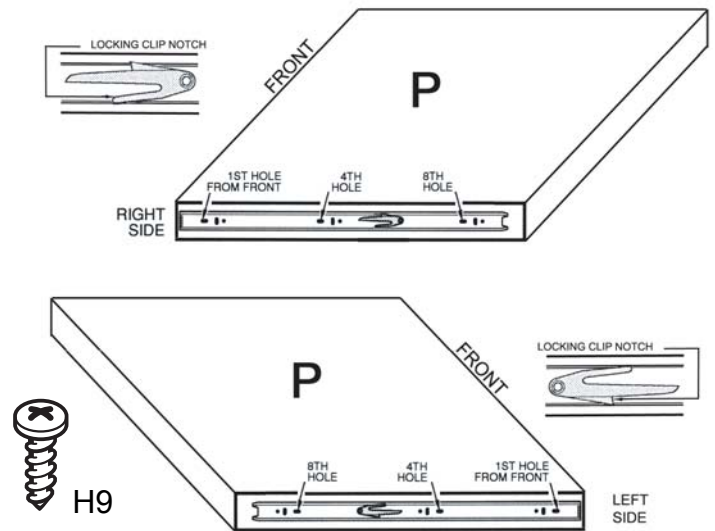

## #21

Extend cabinet portions of the Full Extension Slides completely out.

Slide the channels of the Keyboard Shelf (K) and Printer Shelf (P) onto the slides of the cabinet as shown until secured by the locking clips.

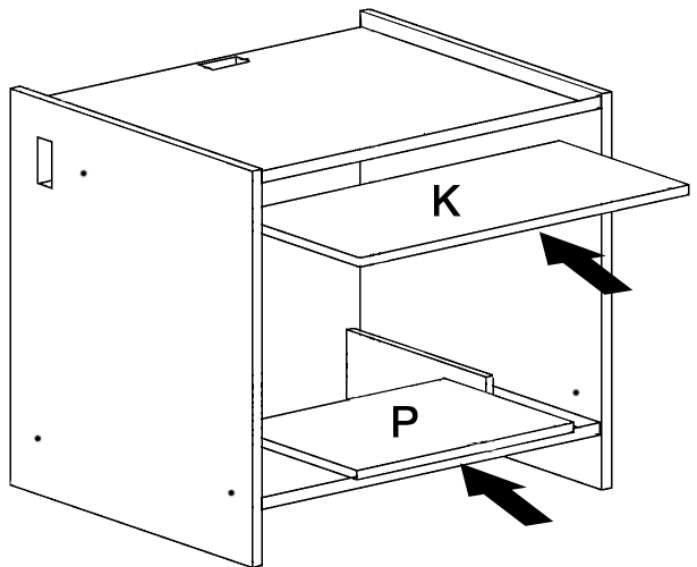

## #22

Insert a Grommet (H10) into the Left Side (A), Right Side (B), Top (C), and Bottom (E).

**Your Glacier Circulation Desk is now fully assembled and ready for use.**

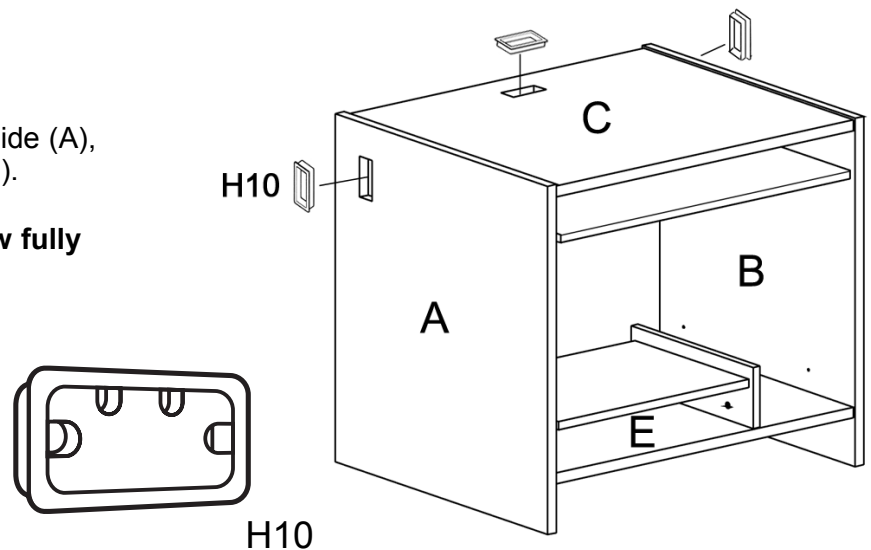

## CONNECTING OTHER WORKSTATIONS:

Remove Grommets from the panels to be connected.

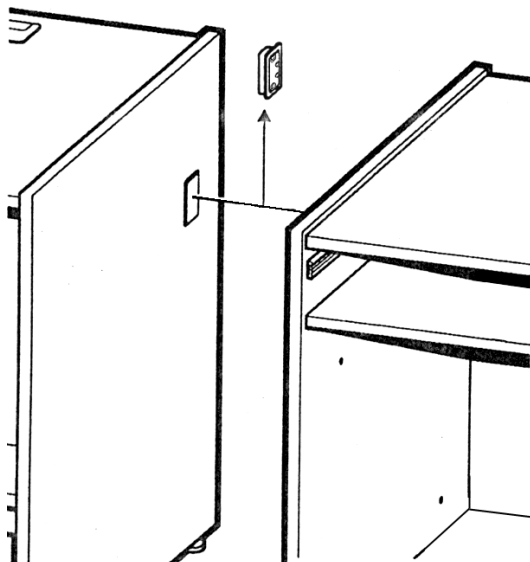

Using a 13/64" bit, drill through the four pilot holes on the inside of each side panel.

Align the side panels of the units to be connected. Tap four Connector Sleeves (H11) through the holes in one side panel and into the holes of the unit to be connected. From the other side, secure the units together using four Connector Screws (H12).

