

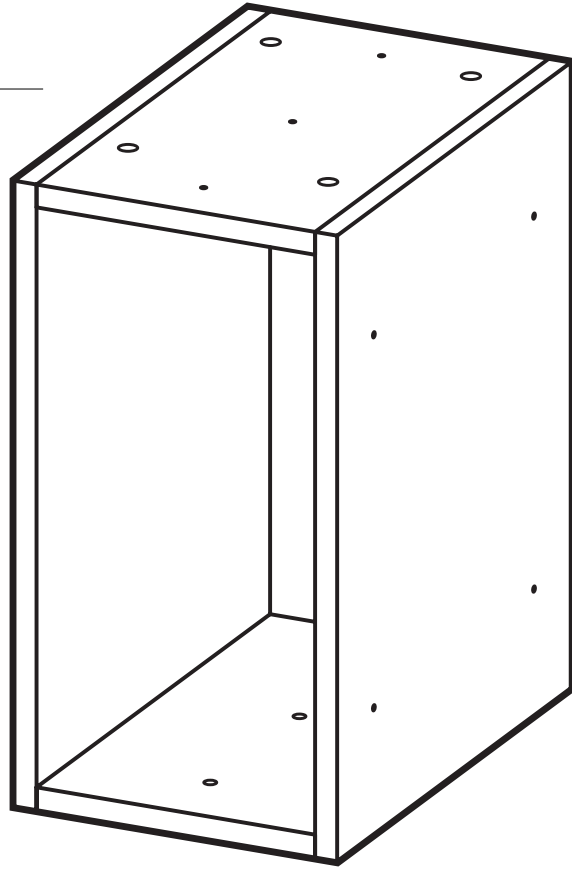

BY  **IRONWOOD**

CIRCULATION DESK **CDCPU**

CPU HOLDER



IMPORTANT!

Assembly may require the assistance of another person.

Before you begin assembly:

READ THE DIRECTIONS all the way through one time. This will speed up the process and help you understand the sequence of steps.

COUNT THE PARTS AND HARDWARE before assembly. This ensures you have received all necessary parts before you begin.

TOOLS: You may need a Phillips head screwdriver, a medium slotted screwdriver or a plastic mallet. To protect your new furniture from damage during assembly, it is recommended to work on a carpeted surface.

In the event any parts are missing from this package, send your name, address, telephone number, and a description of the missing part(s) to: **PARTS, Box 1420, Missoula, MT 59806** or call: **1-800-769-5693** or FAX **1-800-445-5281**.

CAUTION: On assemblies requiring glue, make sure the unit is assembled correctly before gluing. Once this unit is assembled with glue, the manufacturer will not be responsible for damaged parts. Keep a damp cloth or sponge handy to wipe off excess glue.

To care for this furniture, simply wipe with a cloth dampened with glass cleaner containing ammonia-D.

PARTS DIAGRAM

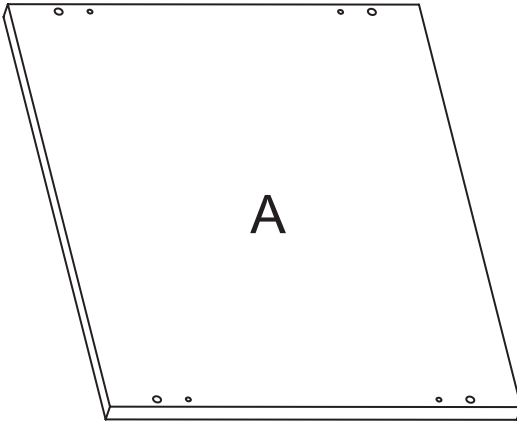

Outside Panel	01051041	1 ea.
---------------	----------	-------

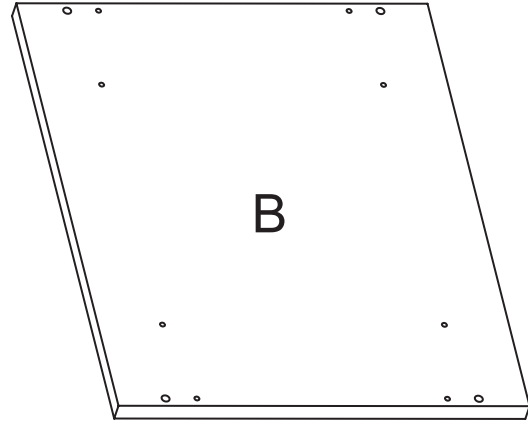

Inside Panel	01051041	1 ea.
--------------	----------	-------

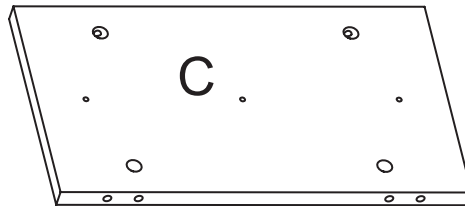

Top/Bottom	01051001	2 ea.
------------	----------	-------

HARDWARE



H1	Minifix Cam	909810	8 ea.
----	-------------	--------	-------



H2	Minifix Bolt	909834	8 ea.
----	--------------	--------	-------



H3	Dowel	195000	8 ea.
----	-------	--------	-------



H4	#8 x 1-1/4" Panhead Screw	901212	7 ea.
----	------------------------------	--------	-------

Using the Minifix System:

Insert the Minifix Cams into the appropriate holes with the arrow facing outwards as shown.

When screwing post into hole, **Do Not** over tighten. Screw post down until bottom face of post flange just touches board surface.

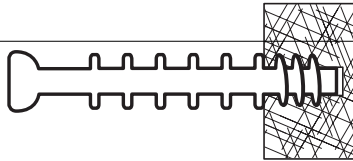
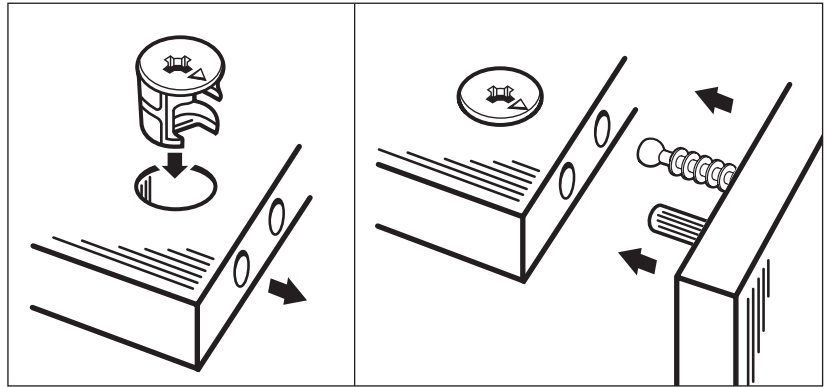

Using the #2 Phillips screwdriver, rotate the Cam Devices a half turn clockwise until snug.

To disassemble, turn the Cam Devices counter-clockwise and remove panels.

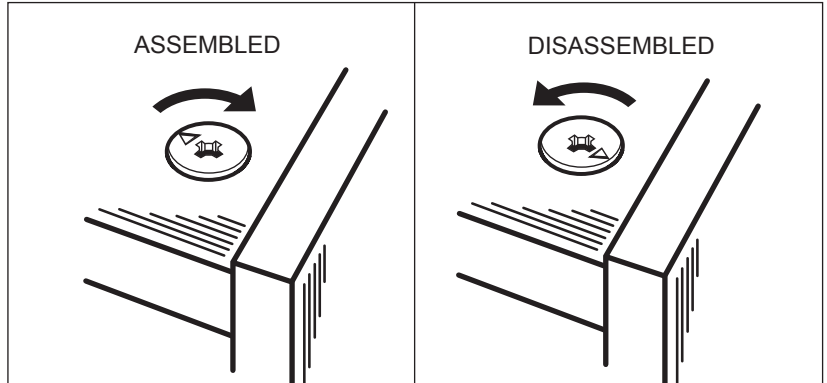

The CDCPU CPU Holder may be assembled for either a lefthand or righthand application.

#1

Place the Top (C) and Bottom (C) on a clean, carpeted surface with the pre-drilled holes facing up. Insert four Minifix Cams (H1) into the Top (C) with the arrows of the cams facing out.

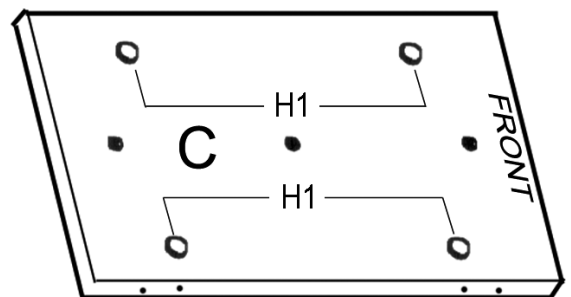
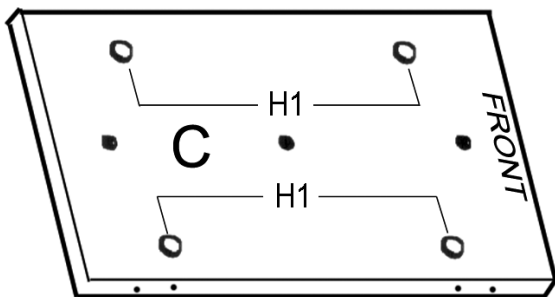

#2

Position the Inside Panel (A) and Outside Panel (B) as shown. Screw four Minifix Bolts (H2) and insert four Dowels (H3) into each Panel where indicated.

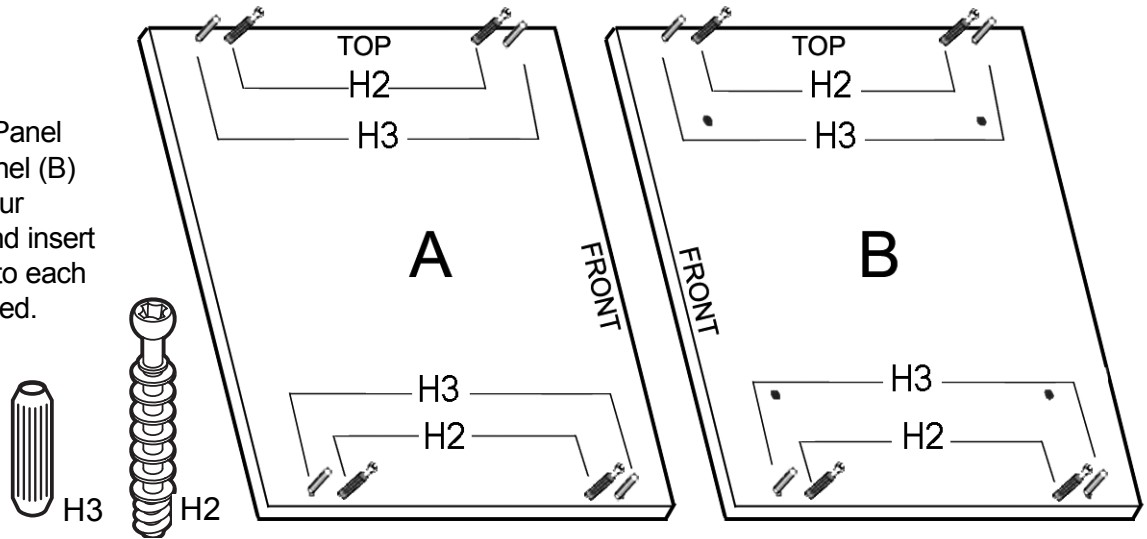

#3

Place Outside Panel (B) with the bolts facing up as shown. Position the Top/Bottom (C) onto the Outside Panel as shown. Turn the arrows of the indicated Minifix Cams (H1) clockwise to secure.

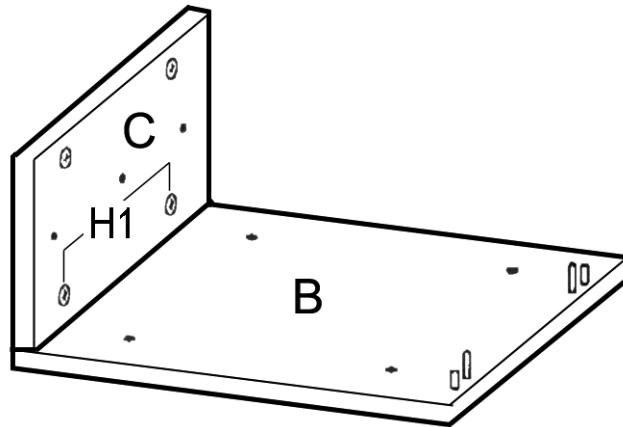

#4

Position the Top/Bottom (C) with the edge as shown onto the Outside Panel (B) and turn the arrows of the indicated cams (H1) clockwise to secure.

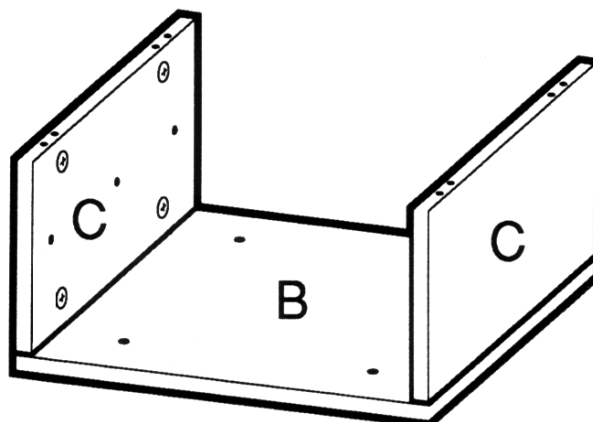

#5

Position the Inside Panel (A) with the edge as shown onto the unit. Turn the arrows of the cams (H1) of the Top (C) and the Bottom (C) clockwise to secure.

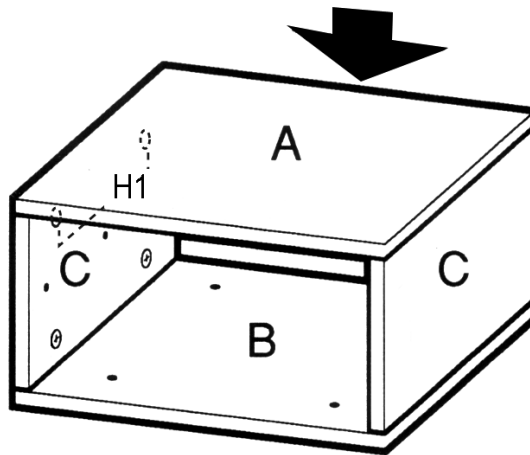

#6

With the assistance of another person, position the CPU Holder unit into the selected side of the Desk unit. Using three #8 x 1-¼" Panhead Screws (H4), attach the Top (C) to the underside of the desk as shown.

Do not fully tighten these screws yet!

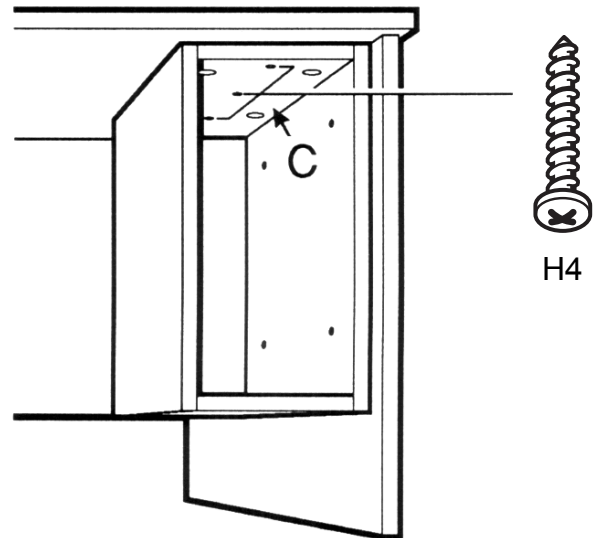

#7

Using four #8 x 1-¼" Panhead Screws (H4) through the pre-drilled holes, attach the Outside Panel (B) to the side of the desk as shown.

Tighten all screws (H4) at this time!

