



BY  **IRONWOOD**

CIRCULATION DESK

CD36R

RISER UNIT

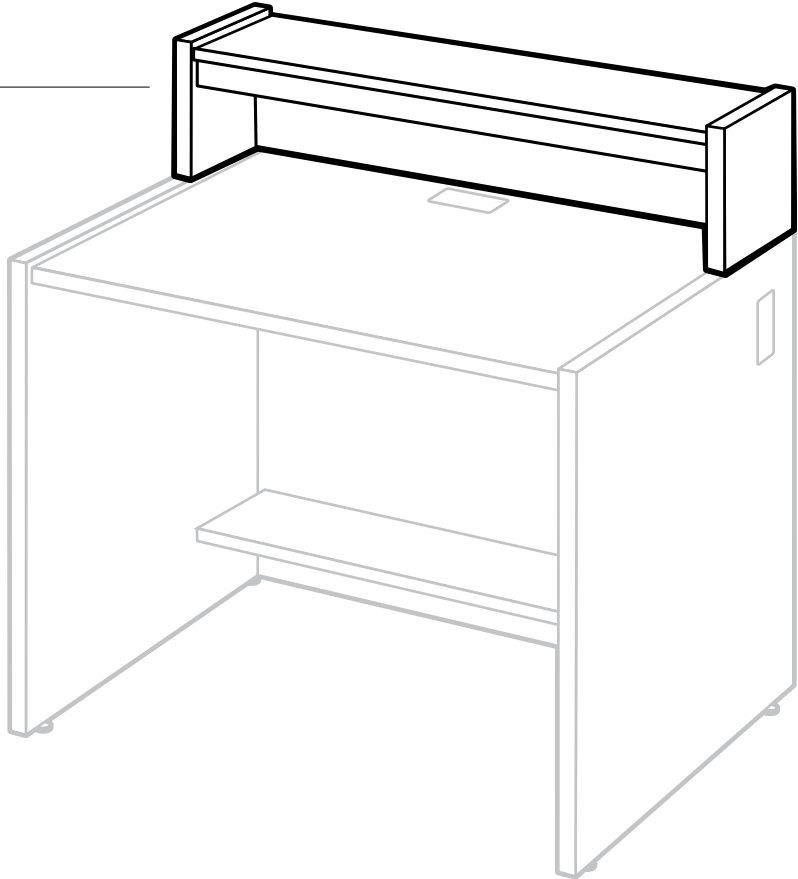

IMPORTANT!

Assembly may require the assistance of another person.

Before you begin assembly:

READ THE DIRECTIONS all the way through one time. This will speed up the process and help you understand the sequence of steps.

COUNT THE PARTS AND HARDWARE before assembly. This ensures you have received all necessary parts before you begin.

TOOLS: You may need a Phillips head screwdriver, a medium slotted screwdriver or a plastic mallet. To protect your new furniture from damage during assembly, it is recommended to work on a carpeted surface.

In the event any parts are missing from this package, send your name, address, telephone number, and a description of the missing part(s) to: **PARTS, Box 1420, Missoula, MT 59806** or call: **1-800-769-5693** or **FAX 1-800-445-5281**.

CAUTION: On assemblies requiring glue, make sure the unit is assembled correctly before gluing. Once this unit is assembled with glue, the manufacturer will not be responsible for damaged parts. Keep a damp cloth or sponge handy to wipe off excess glue.

To care for this furniture, simply wipe with a cloth dampened with glass cleaner containing ammonia-D.

PARTS DIAGRAM

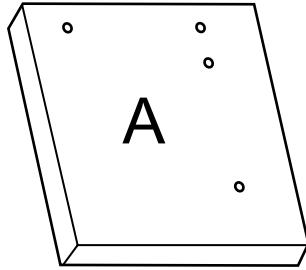

Left Side	01011641	1 ea.
-----------	----------	-------

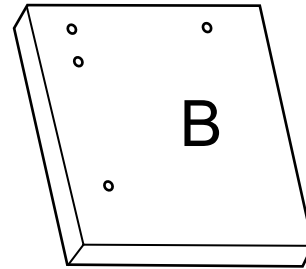

Right Side	01011641	1 ea.
------------	----------	-------

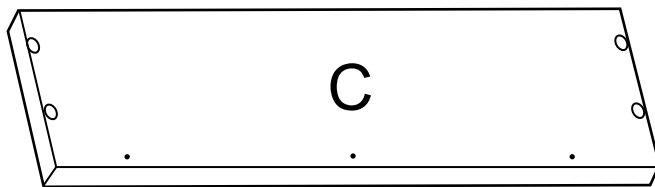

Top	01011601	1 ea.
-----	----------	-------

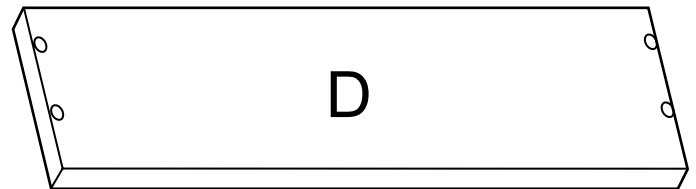

Back	01011652	1 ea.
------	----------	-------

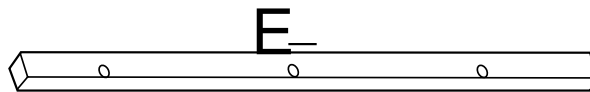

Facia Strip	01011686	1 ea.
-------------	----------	-------

HARDWARE



H1	Rafix Cam	909909	4 ea.
----	-----------	--------	-------

H3	Rafix Bolt	909925	11 ea.
----	------------	--------	--------



H2	Rafix Flush Cam	909834	7 ea.
----	-----------------	--------	-------

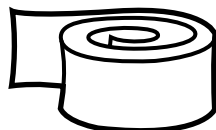

H4	Attachment Tape	298530	2 ea.
----	-----------------	--------	-------

Insert the Rafix Cams into the appropriate holes. The flat edge of the cam should be facing the edge of the panel.

Slide Rafix Cams of the panel to be attached onto the corresponding posts.

When screwing post into hole, **Do Not** over tighten. Screw post down until bottom face of post flange just touches board surface.

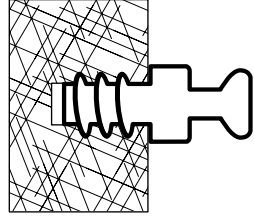

Using a #3 Phillips screwdriver, turn the rotating portion of the Rafix Cam a 1/2 turn clockwise to secure. **IMPORTANT!** Do not exceed 1/2 turn when tightening cams. Turn 1/2 turn counterclockwise to disassemble and remove panel.

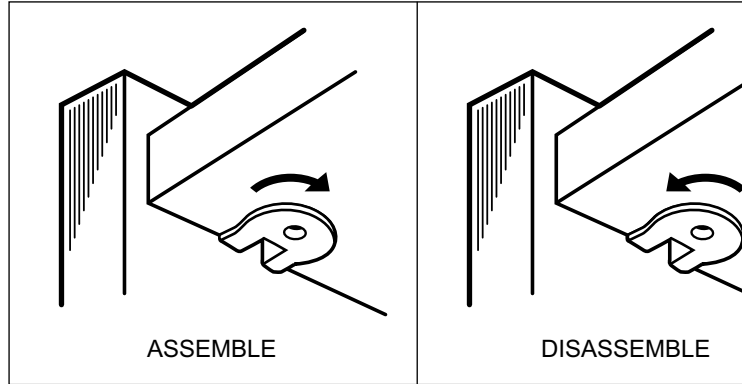
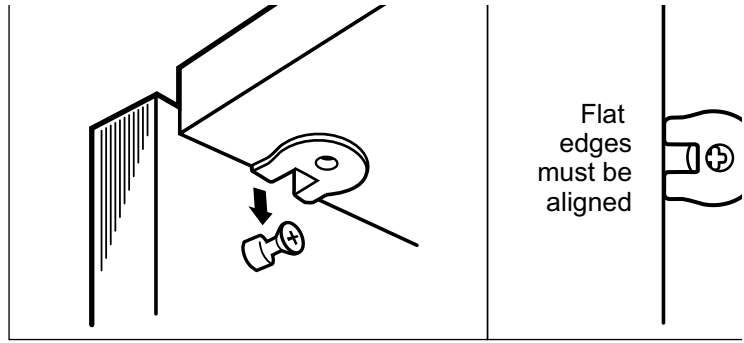

#1

Insert four Rafix Cams (H1) into the Top (C) and Rafix Flush cams (H2) into Back (D)



H1

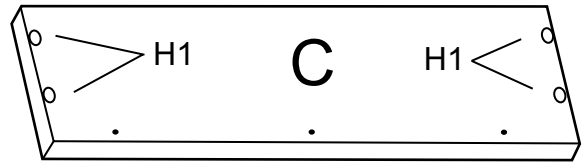

H2

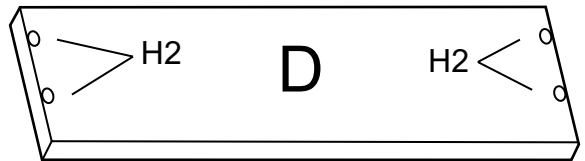

#2

Insert three Rafix Bolts (H3) into the Facia Strip (E)

Position the Rafix Bolts into the corresponding holes in the Top (C).

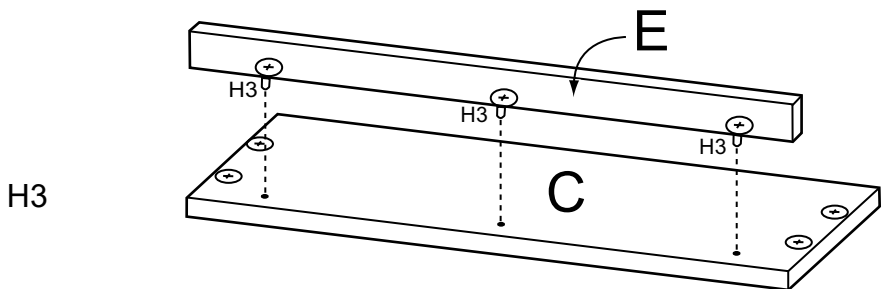

#3

Screw four Rafix Bolts (H4) into the Left Side (A) and Right Side (B) where indicated.

H3

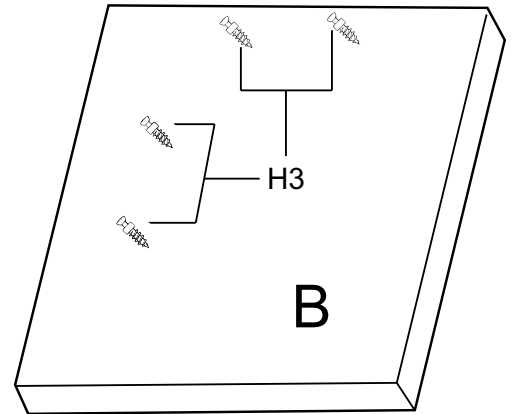
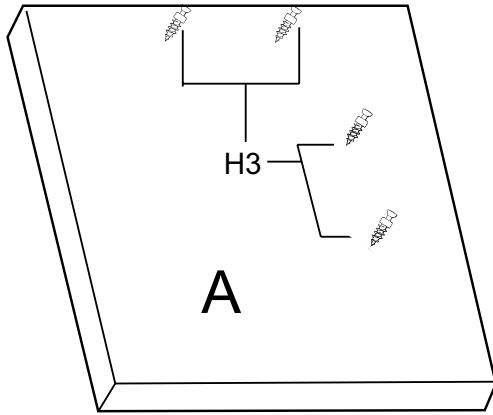
**#4**

Place the Top (C) and Facia Strip (E) on some packing material as shown. Position the bolts Left Side (A) into the Top (C) and turn cams clockwise to secure.

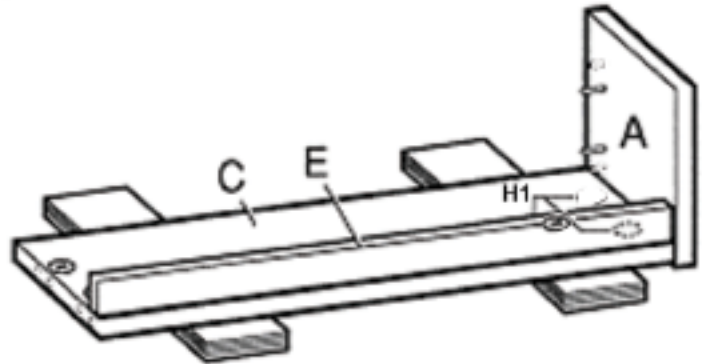
**#5**

Position the Back (D) onto the bolts of the Left Side (A) and turn the cams (H1) clockwise to secure.

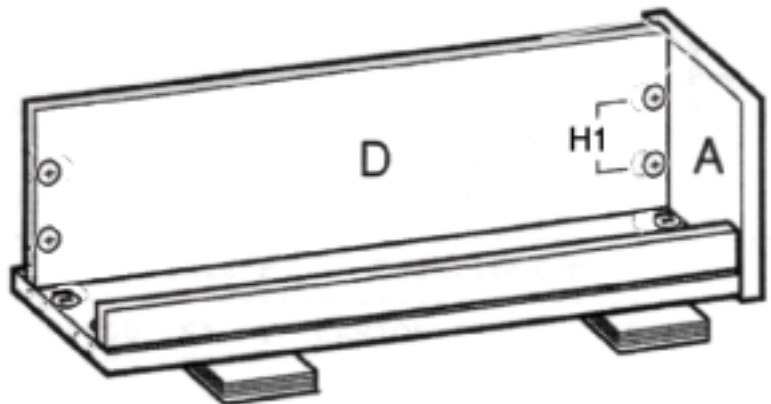
**#6**

Position the Right Side (B) onto the unit and turn the cams (H1) clockwise to secure.

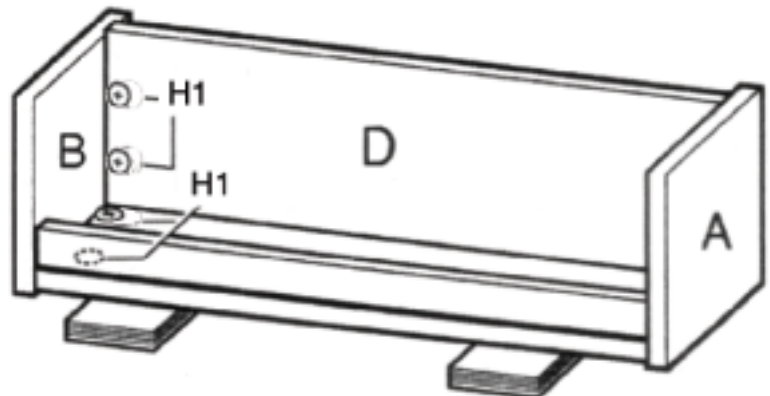

#7

Uncoil the Tape Strips (H4) and affix one strip onto each of the bottom edges of the Left Side (A) and Right Side (B).

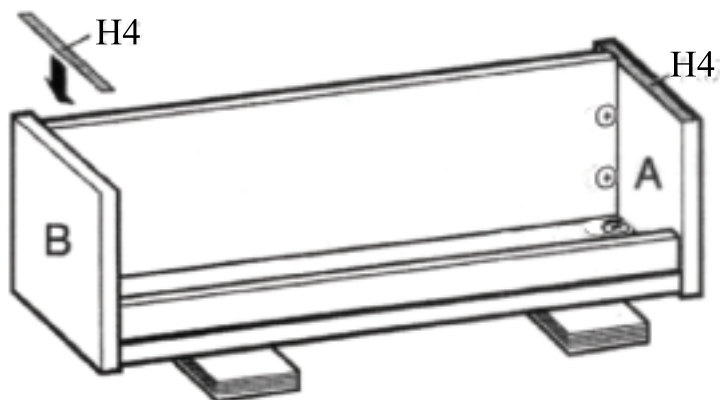

#8

Remove the backing from each Tape Strip (H4) and carefully align rear and side edges of the Riser and the unit to be attached as shown. When aligned, place the Riser on the desk unit.

Note: It will be difficult to remove or reposition the units once joined.

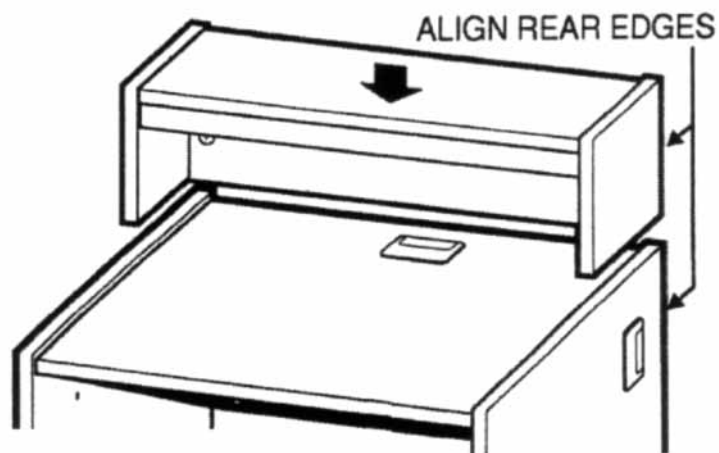

#9

Your Glacier Riser is now fully installed to the Desk Unit and is ready for use.

