

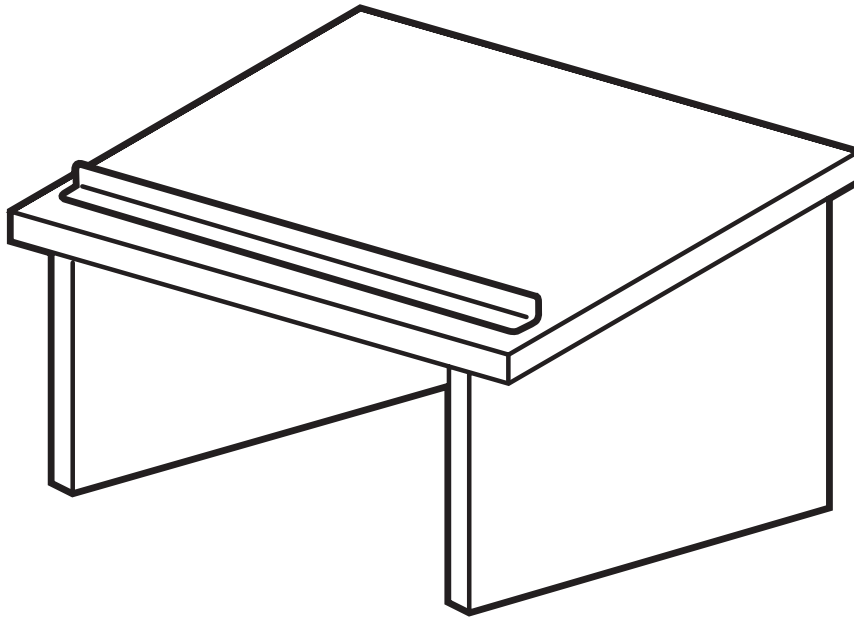

IRONWOOD

TTL

**TABLE TOP
LECTERN**



IMPORTANT!

Assembly may require the assistance of another person.

Before you begin assembly:

READ THE DIRECTIONS all the way through one time. This will speed up the process and help you understand the sequence of steps.

COUNT THE PARTS AND HARDWARE before assembly. This ensures you have received all necessary parts before you begin.

TOOLS: You may need a Phillips head screwdriver, a medium slotted screwdriver or a plastic mallet. To protect your new furniture from damage during assembly, it is recommended to work on a carpeted surface.

In the event any parts are missing from this package, send your name, address, telephone number, and a description of the missing part(s) to: **PARTS, Box 1420, Missoula, MT 59806** or call: **1-800-769-5693** or **FAX 1-800-445-5281**.

CAUTION: On assemblies requiring glue, make sure the unit is assembled correctly before gluing. Once this unit is assembled with glue, the manufacturer will not be responsible for damaged parts. Keep a damp cloth or sponge handy to wipe off excess glue.

To care for this furniture, simply wipe with a cloth dampened with glass cleaner containing ammonia-D.

Insert the Rafix Cams into the appropriate holes. The flat edge of the cam should be facing the edge of the panel.

Slide Rafix Cams of the panel to be attached onto the corresponding posts.

When screwing post into hole, **Do Not** over tighten. Screw post down until bottom face of post flange just touches board surface.

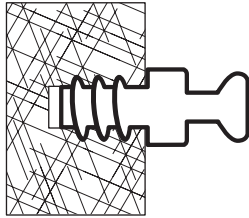

Using a #3 Phillips screwdriver, turn the rotating portion of the Rafix Cam a 1/2 turn clockwise to secure. **IMPORTANT!** Do not exceed 1/2 turn when tightening cams. Turn 1/2 turn counterclockwise to disassemble and remove panel.

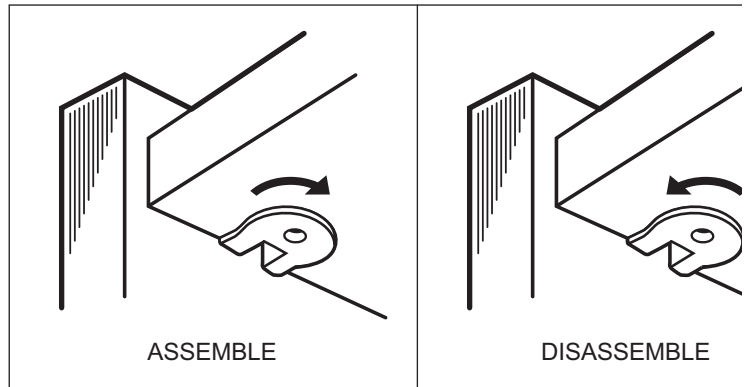
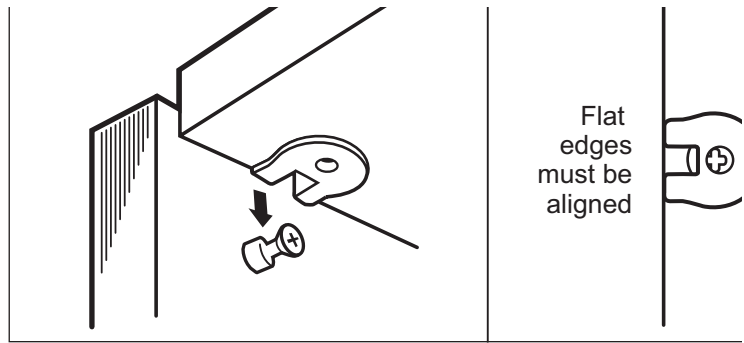

PARTS DIAGRAM

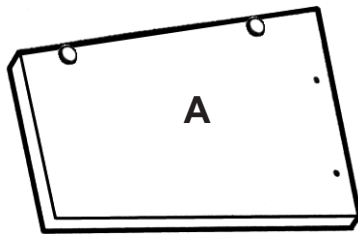

LECTERN Left Side	05870241	1 ea.
-------------------	----------	-------

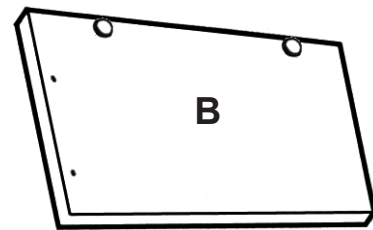

LECTERN Right Side	05870241	1 ea.
--------------------	----------	-------

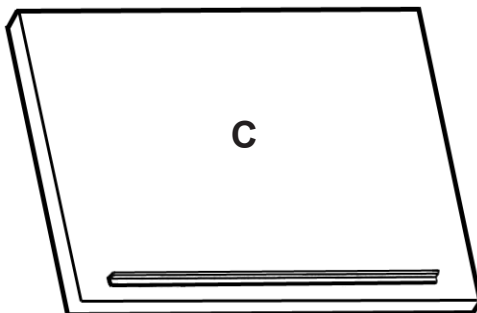

LECTERN Top	05870101	1 ea.
-------------	----------	-------

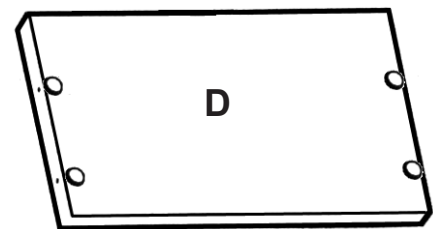

LECTERN Back	05870252	1 ea.
--------------	----------	-------

HARDWARE



H1	Rafix Cam	909909	8 ea.
----	-----------	--------	-------



H2	Rafix Bolt	909925	8 ea.
----	------------	--------	-------

#1

Place the Left Lectern Side (A), Right Lectern Side (B) and Lectern Back (D) on a clean, carpeted surface or foam padding with the cam holes upright as shown. Insert Rafix Cams (H1) into the Left Lectern Side, Right Lectern Side and Lectern Back where indicated with the arrows of the cams facing out.

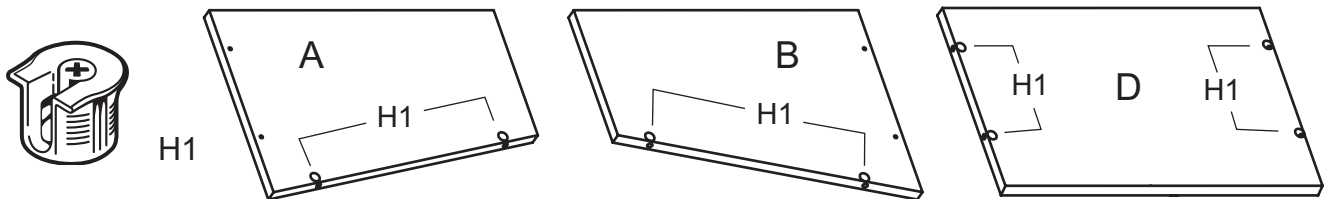

#2

Screw four Rafix Bolts (H2) into the predrilled holes in the underside of the Lectern Top (C) where indicated. Screw Rafix bolts into the predrilled holes on the Left Side (A) and Right Side (B) where indicated.

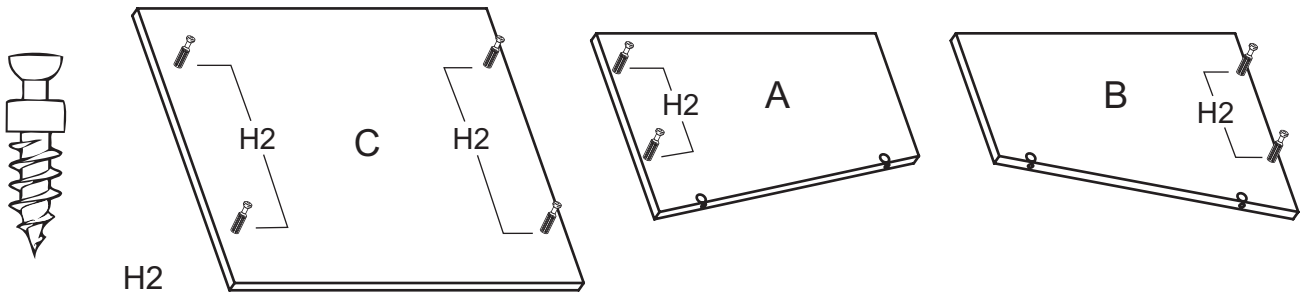

#3

Position the Lectern Back (D) onto the Left Lectern Side (A) as shown. Turn the Rafix Cams (H1) to secure.

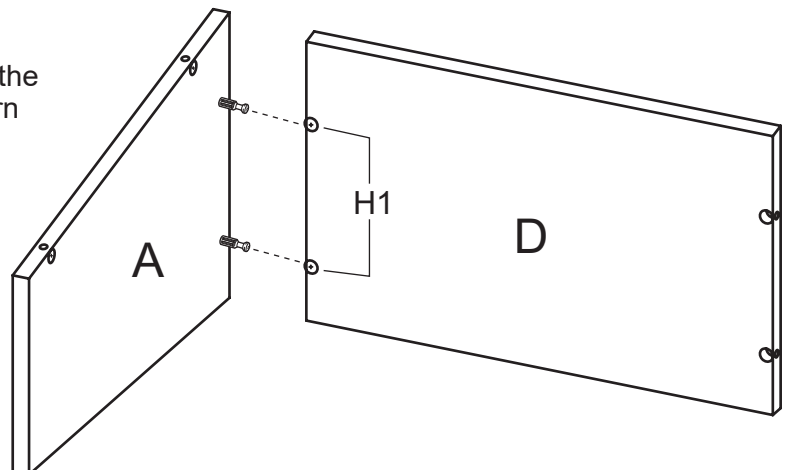

#4

Position the Lectern Side (B) onto the Left Lectern Back (D) and turn the cams (H1) to secure.

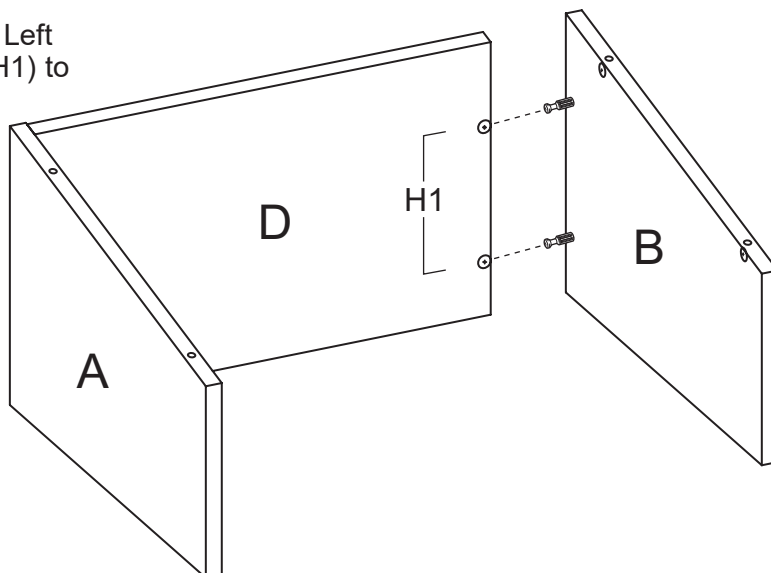

#5

Position the Rafx bolts (H2) on the LECTERN Top into the corresponding holes of the Left Lectern Side (A) and the Right Lectern Side (B) and turn the cams (H1) to secure in place.

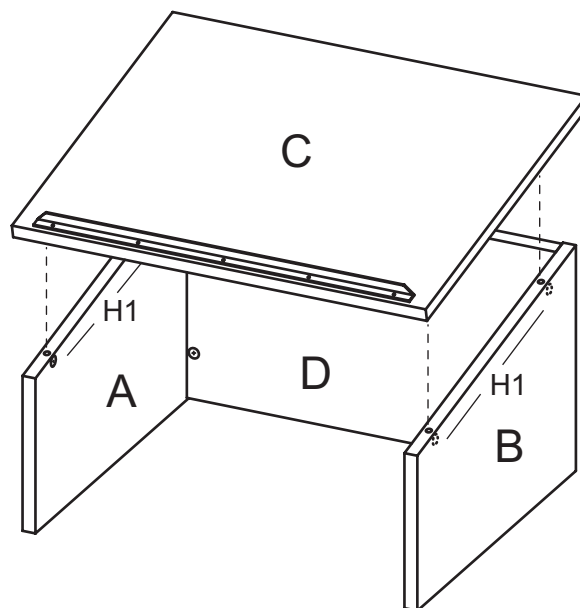

#6

Your Table Top Lectern is now fully assembled and ready for use.

