

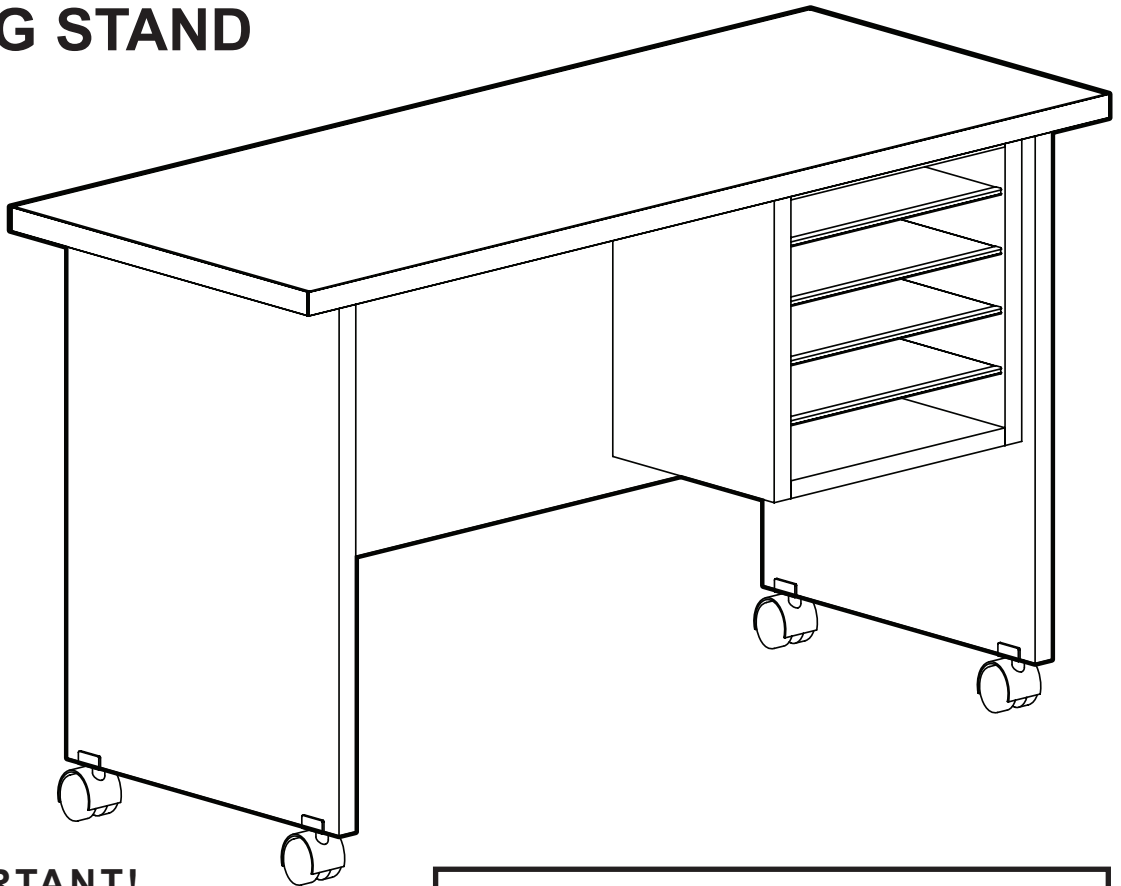

DTS

DELUXE TYPING STAND



IMPORTANT!

Assembly may require the assistance of another person.

Before you begin assembly:

READ THE DIRECTIONS all the way through one time. This will speed up the process and help you understand the sequence of steps.

COUNT THE PARTS AND HARDWARE before assembly. This ensures you have received all necessary parts before you begin.

TOOLS: You may need a Phillips head screwdriver, a medium slotted screwdriver or a plastic mallet. To protect your new furniture from damage during assembly, it is recommended to work on a carpeted surface.

In the event any parts are missing from this package, send your name, address, telephone number, and a description of the missing part(s) to: **PARTS, Box 1420, Missoula, MT 59806** or call: **1-800-769-5693** or **FAX 1-800-445-5281**.

CAUTION: On assemblies requiring glue, make sure the unit is assembled correctly before gluing. Once this unit is assembled with glue, the manufacturer will not be responsible for damaged parts. Keep a damp cloth or sponge handy to wipe off excess glue.

To care for this furniture, simply wipe with a cloth dampened with glass cleaner containing ammonia-D.

PARTS DIAGRAM

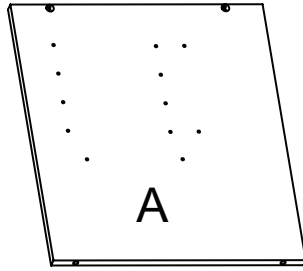

Left Side Panel	05850141	1 ea.
-----------------	----------	-------

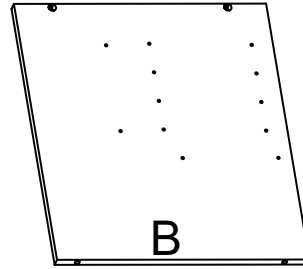

Right Side	05850341	1 ea.
------------	----------	-------

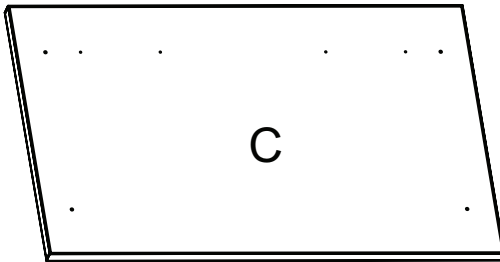

Worksurface	05850101	1 ea.
-------------	----------	-------

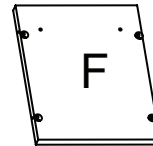

Paper Rack Top	05850118	1 ea.
----------------	----------	-------

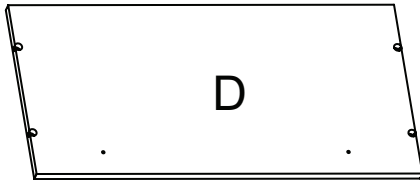

Back	05850152	1 ea.
------	----------	-------

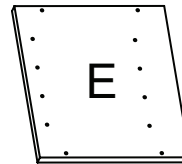

Paper Rack Side	05850116	2 ea.
-----------------	----------	-------

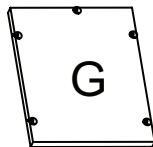

Paper Rack Bottom	05850119	1 ea.
-------------------	----------	-------

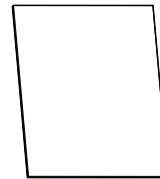

1/4" black shelves	4 ea.
--------------------	-------

HARDWARE



H1	Rafix Bolt	909925	15 ea.
----	------------	--------	--------



H2	Rafix Flush Cam	909911	8 ea.
----	-----------------	--------	-------



H3	Rafix Cam	909909	9 ea.
----	-----------	--------	-------

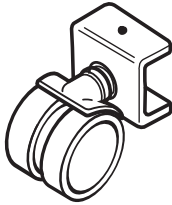

H6	Caster Locking Caster	H1192	2 ea. 2 ea.
----	-----------------------	-------	----------------



H7	Caster Screw		4 ea.
----	--------------	--	-------



H8	Washer Head Screw	920201	2 ea.
----	-------------------	--------	-------

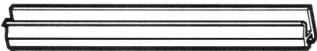

H9	Label Holders	H3402	4 ea.
----	---------------	-------	-------

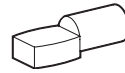

H10	Shelf Pins	H1021	16 ea.
-----	------------	-------	--------

Using the Rafix System:

Insert the Rafix Cams into the appropriate holes. The flat edge of the cam should be facing the edge of the panel.

Slide Rafix Cams of the panel to be attached onto the corresponding posts.

When screwing post into hole, **Do Not** over tighten. Screw post down until bottom face of post flange just touches board surface.

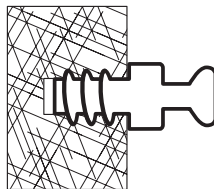

Using a #3 Phillips screwdriver, turn the rotating portion of the Rafix Cam a 1/2 turn clockwise to secure. **IMPORTANT!** Do not exceed 1/2 turn when tightening cams. Turn 1/2 turn counterclockwise to disassemble and remove panel.

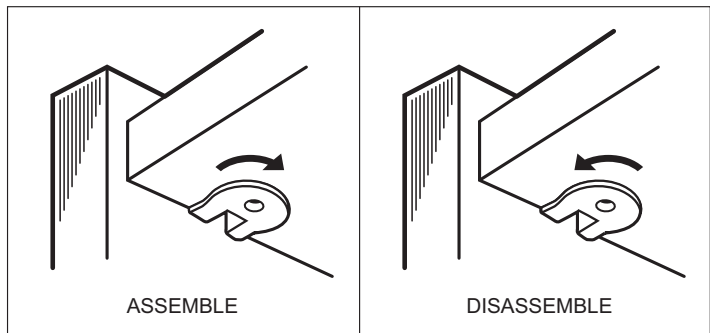
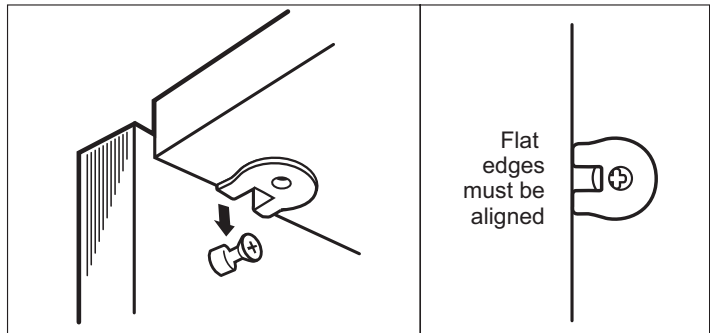

#1

Screw four Rafix Bolts (H1) into the pre-drilled holes of the Worksurface (C) where indicated.

H1

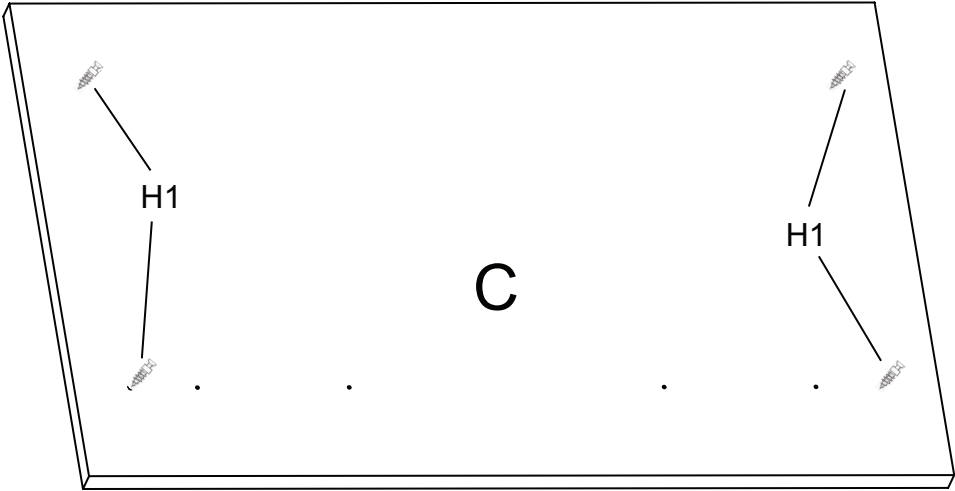

#2

- Screw two Rafix Bolts (H1) into pre-drilled holes of each Side (A and B) where indicated.
- Insert two Rafix Cams (H3) facing out into each Side (A and B) as shown.

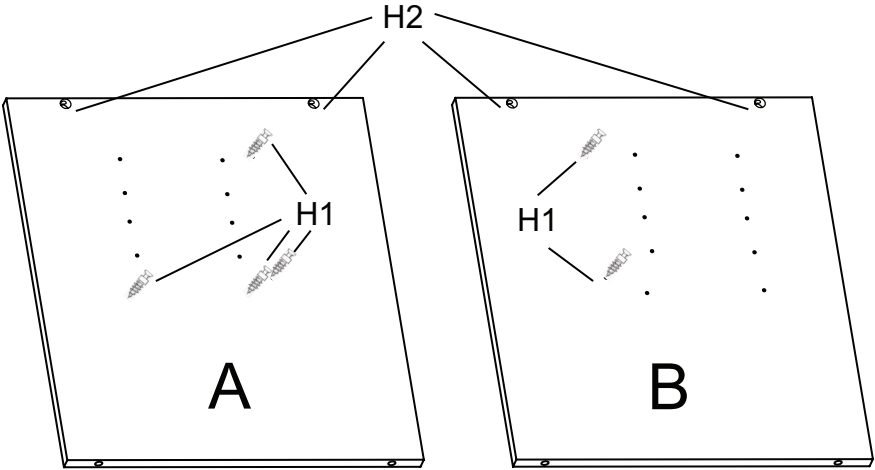

#3

Place Casters (H6) over hold of bottom of A and B and insert caster screw to secure.

NOTE: The locking Casters should be installed toward the front of the unit.

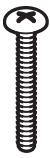

H7

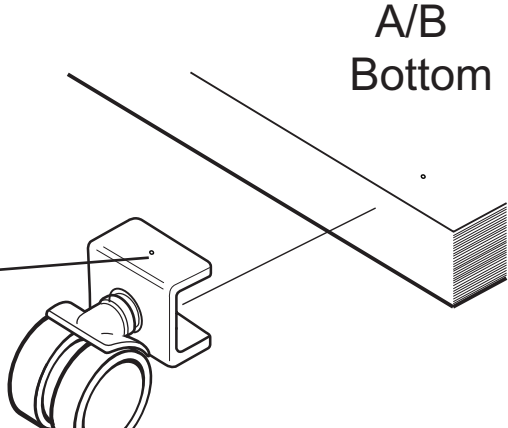

#4

Insert four (H2) into the Back (D) as shown. Position H2 the Back onto the Left Side (A) as shown.

NOTE: Note the hole orientation on Back (D).

Rotate Minifix Cams clockwise to lock in place.

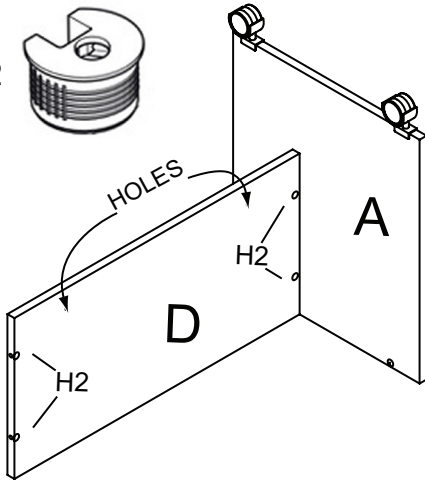

#5

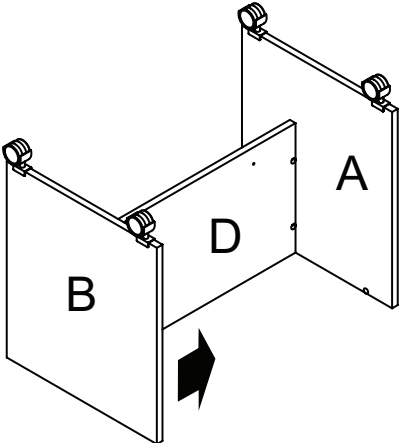

Position the Right Side (B) onto the Back (D) as shown.

Rotate cams to lock in place

#6

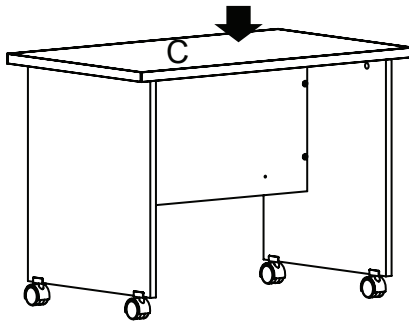

Turn the unit upright. Position the Cams and Dowels of the Worksurface (C) into the Rafix Cams of the unit as shown.

Rotate Cams (H3) to lock in place.

#7

Insert 4 rafix cams (H3) into Paper Rack Top (F) and 5 rafix cams into Paper Rack Bottom(G)

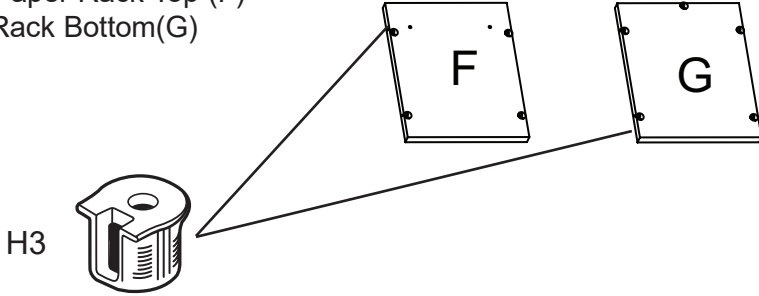

#8

Take Paper Rack Side (E) and place 4 rafx bolts (H1) in designated holes. Position Side panel and insert bolts into rafx cams of (F) and (G). Turn cams to secure.

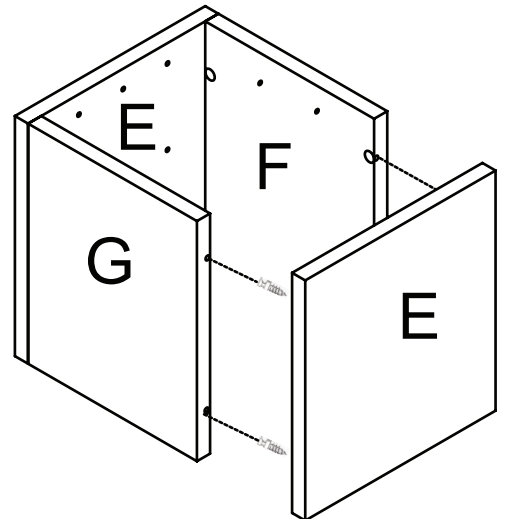
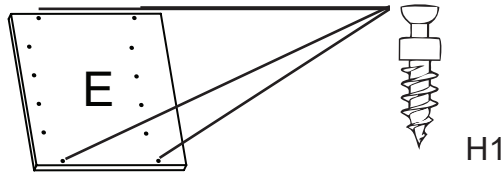

#9

Select either a left or right-hand Paper Rack placement. Attach Paper Rack unit to the underside of the Worksurface (C) using two Washerhead Screws (H8) in the pre-drilled holes as shown. Turn cam of Paper Rack Bottom (G) to secure in palce

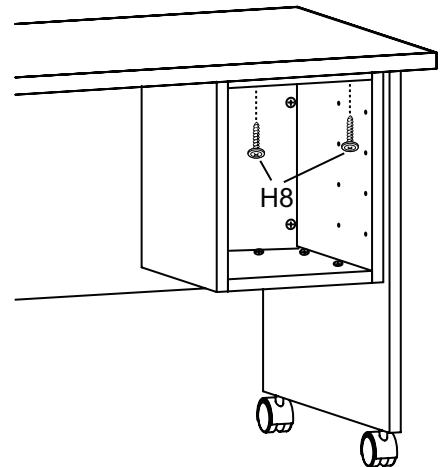

#10

Insert eight Shelf Pins into the pre-drilled holes in both Paper Rack sides as shown.

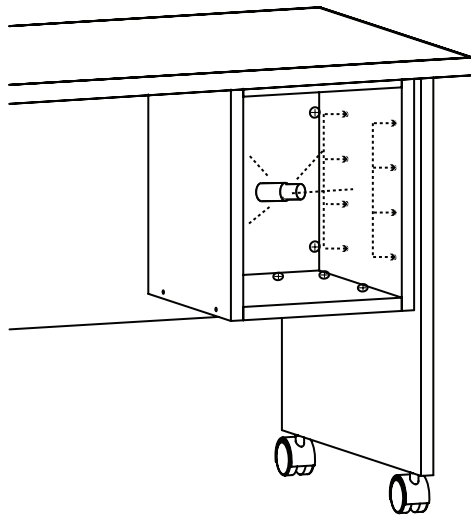

#11

Put label holders on shelves. Insert shelves to sit on shelf pins

Assembly of the Deluxe Typing Stand is now complete.