

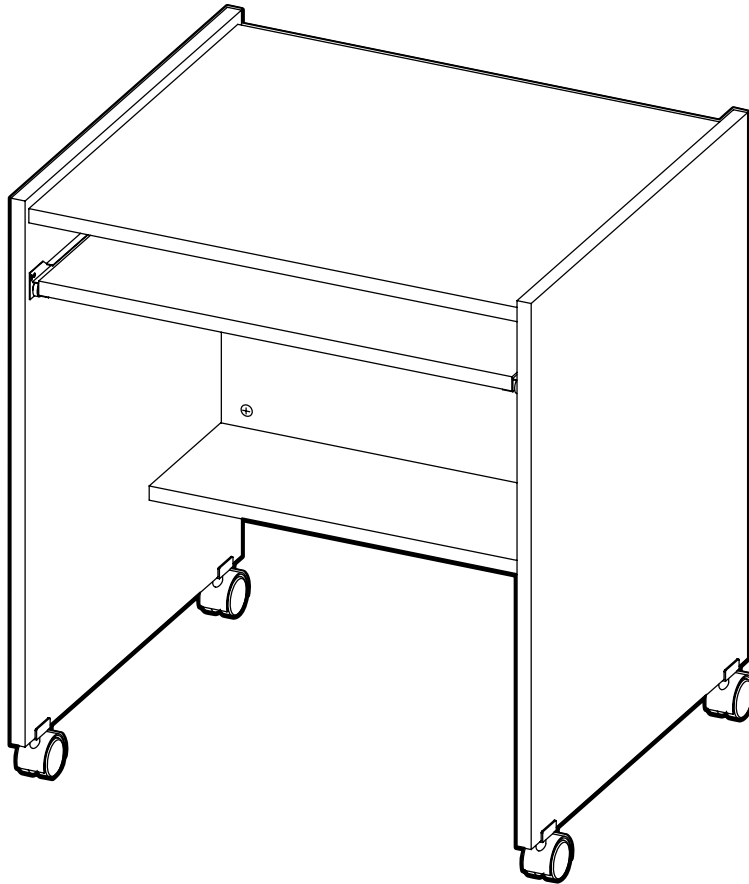

IRONWOOD

CUB

COMPUTER STAND



IMPORTANT!

Assembly may require the assistance of another person.

Before you begin assembly:

READ THE DIRECTIONS all the way through one time. This will speed up the process and help you understand the sequence of steps.

COUNT THE PARTS AND HARDWARE before assembly. This ensures you have received all necessary parts before you begin.

TOOLS: You may need a Phillips head screwdriver, a medium slotted screwdriver or a plastic mallet. To protect your new furniture from damage during assembly, it is recommended to work on a carpeted surface.

In the event any parts are missing from this package, send your name, address, telephone number, and a description of the missing part(s) to: **PARTS, Box 1420, Missoula, MT 59806** or call: **1-800-769-5693** or **FAX 1-800-445-5281**.

CAUTION: On assemblies requiring glue, make sure the unit is assembled correctly before gluing. Once this unit is assembled with glue, the manufacturer will not be responsible for damaged parts. Keep a damp cloth or sponge handy to wipe off excess glue.

To care for this furniture, simply wipe with a cloth dampened with glass cleaner containing ammonia-D.

PARTS DIAGRAM

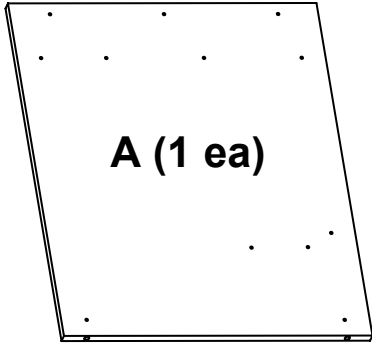

A (1 ea)

Left Side	05841341
-----------	----------

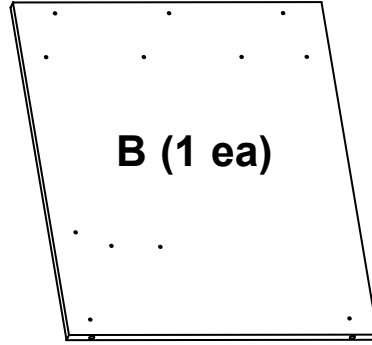

B (1 ea)

Right Side	05841341
------------	----------

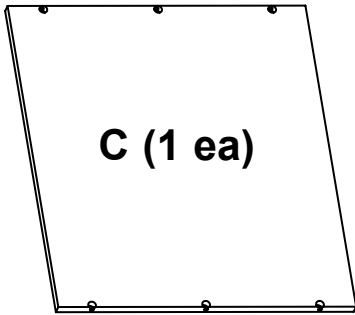

C (1 ea)

Top	05840301
-----	----------

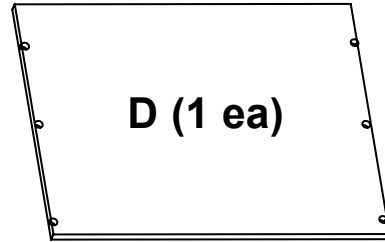

D (1 ea)

Back	05841352
------	----------

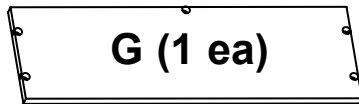

G (1 ea)

Storage Shelf	05840332
---------------	----------

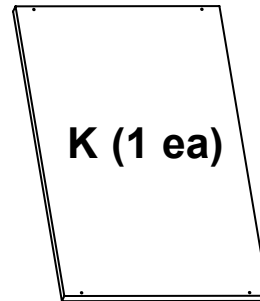

K (1 ea)

Keyboard Shelf	05840328
----------------	----------

HARDWARE

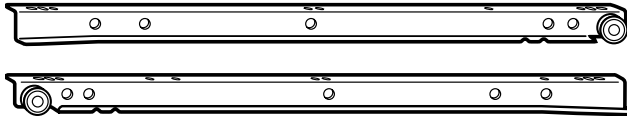

S4

Drawer Slide	490260	1 pr.
--------------	--------	-------

S3

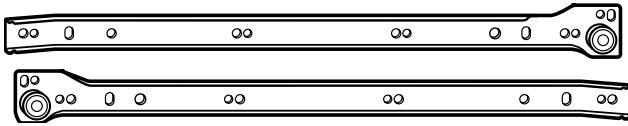

S1

Slide Channel	490260	1 pr.
---------------	--------	-------

S2



H1	Varianta Screw	988060	6 ea.
----	----------------	--------	-------



H2	Rafx Bolt	909925	17 ea.
----	-----------	--------	--------



H3	Flush Rafx Cam	909911	6 ea.
----	----------------	--------	-------



H4	Rafx Cam	9099109	11 ea.
----	----------	---------	--------

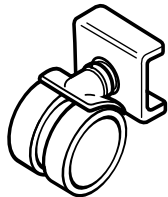

H5	Caster	H1192 H1192-LG	2ea. 2ea.
----	--------	-------------------	--------------



H7	Panhead Screw	901216	4 ea.
----	---------------	--------	-------

Using the Rafix System:

Insert the Rafix Cams into the appropriate holes. The flat edge of the cam should be facing the edge of the panel.

Slide Rafix Cams of the panel to be attached onto the corresponding posts.

When screwing post into hole, **Do Not** over tighten. Screw post down until bottom face of post flange just touches board surface.

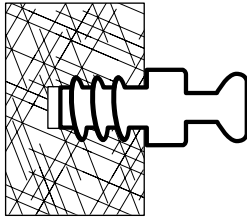

Using a #3 Phillips screwdriver, turn the rotating portion of the Rafix Cam a 1/2 turn clockwise to secure. **IMPORTANT!** Do not exceed 1/2 turn when tightening cams. Turn 1/2 turn counterclockwise to disassemble and remove panel.

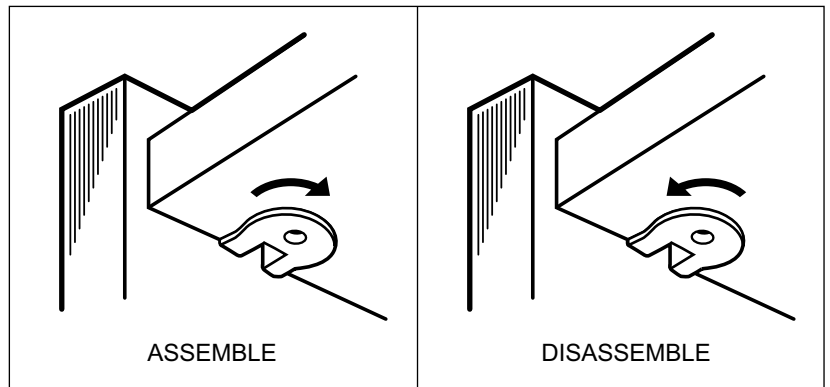
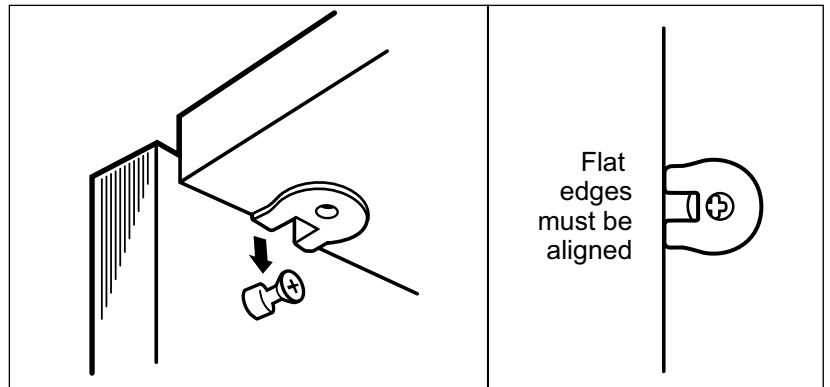

#1

Attach a left Side Channel (S1) to Left Side (A) using Varianta Screws (H1) in the selected pre-drilled holes as shown.

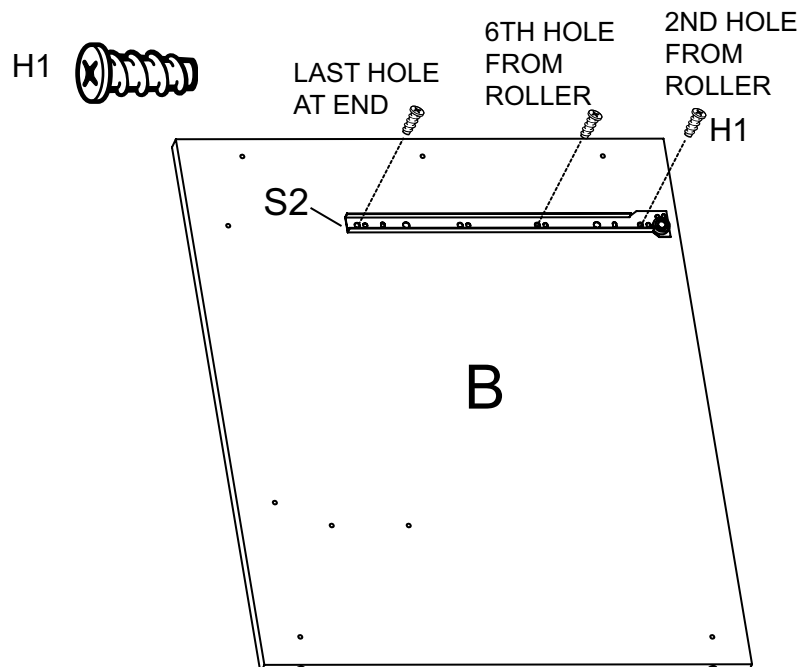

#2

Attach a right Side Channel (S2) to Right Side (B) using Varianta Screws (H1) in the selected pre-drilled holes as shown.

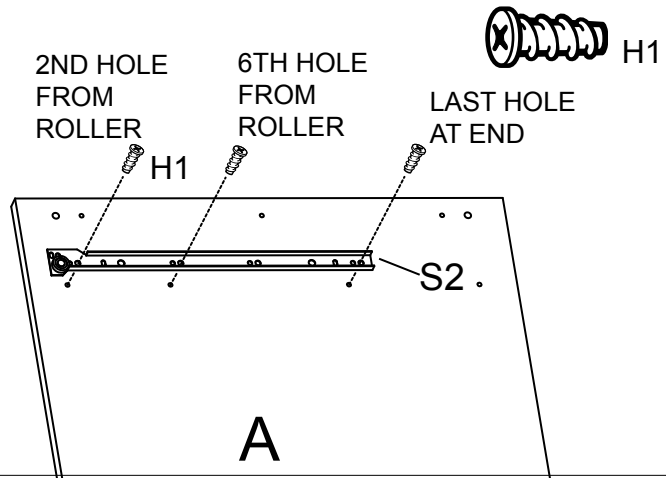

#3

Place the Left Side (A) with the pre-drilled holes facing up as shown. Screw Rafix Bolts (H2) into the indicated holes as shown.

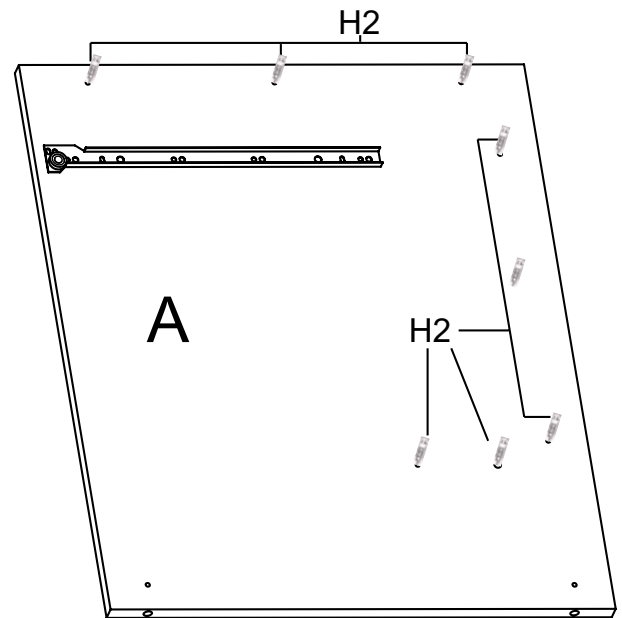
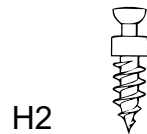

#4

Place the Right Side (B) with the pre-drilled holes facing up as shown. Screw Rafix Bolts (H2) into the indicated holes as shown.

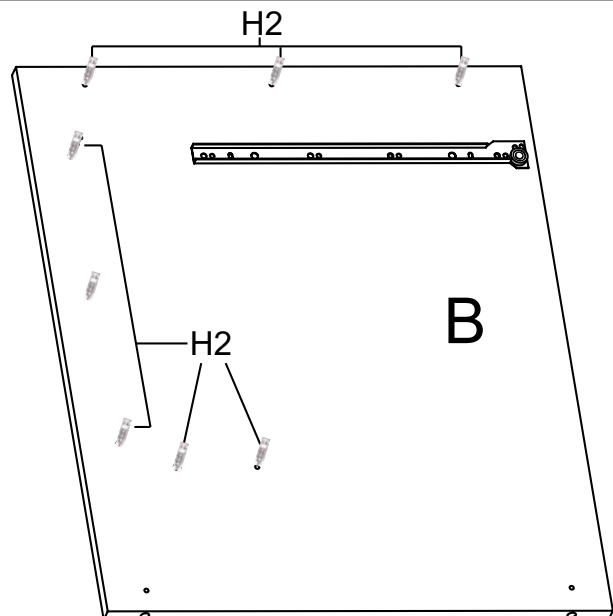
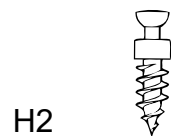

#5

Insert Rafix Cams (H4) into the Top (C)



H4

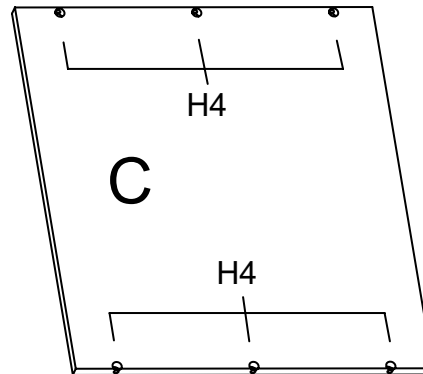

#6

Position the Worksurface (C) onto the bolts of the Left side (A) and turn the Cams (H4) to secure in place.

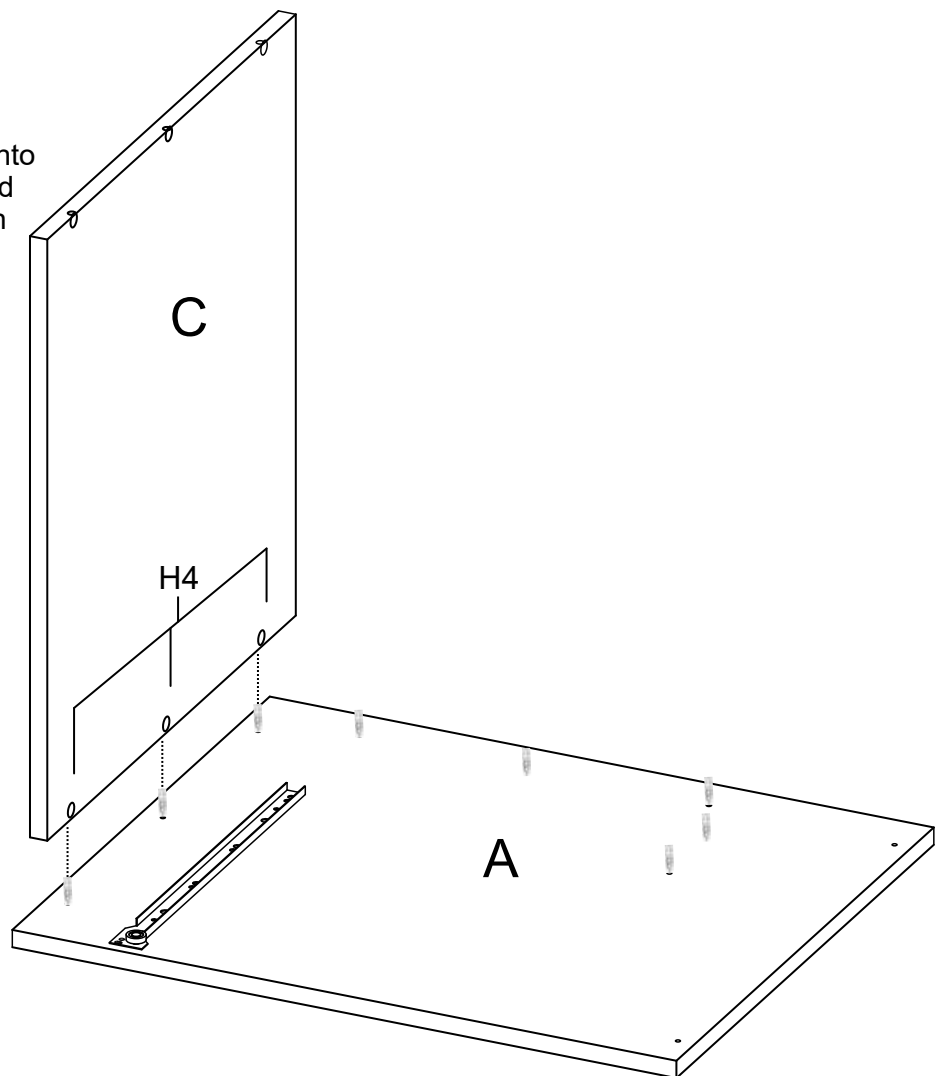

#7

Insert Flush Rafix Cams (H3) into the Back (D). Position the Back onto the bolts of the Left Side (A) and turn the Cams clockwise to secure.

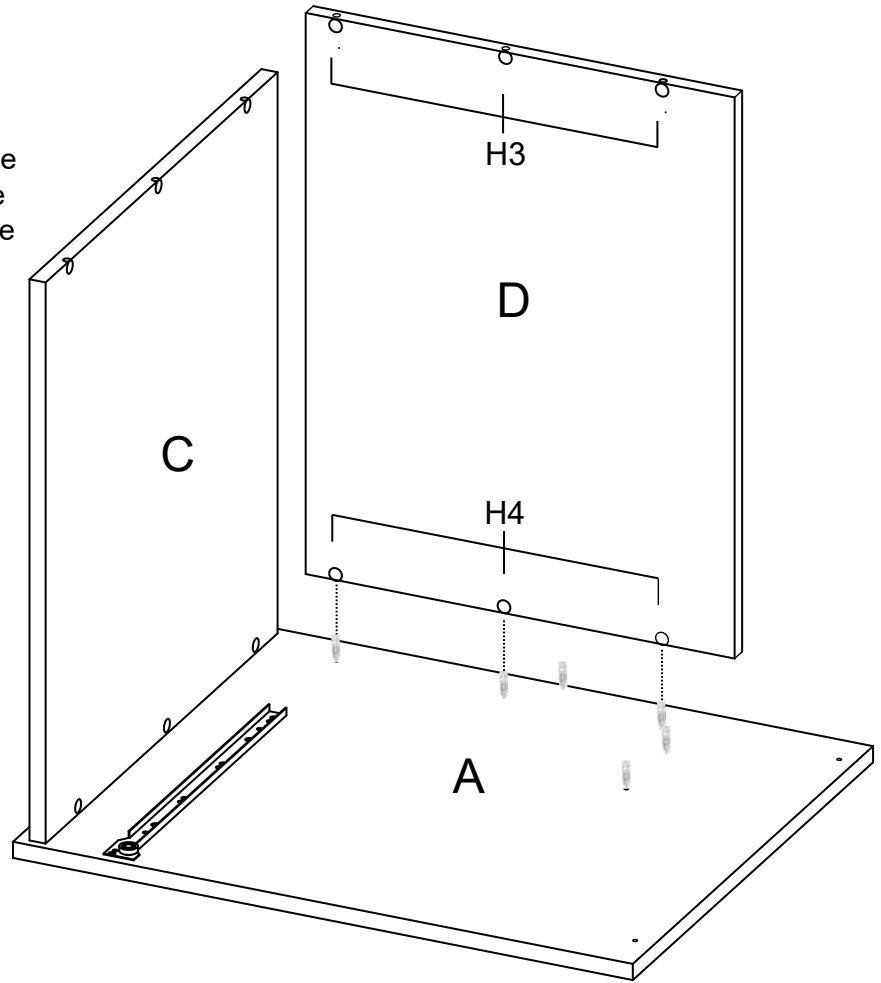

#8

Insert Rafix Cams (H4) into the Storage Shelf (G). Position the Storage Shelf onto the bolts of the Left Side (A) and turn the Cams to secure.

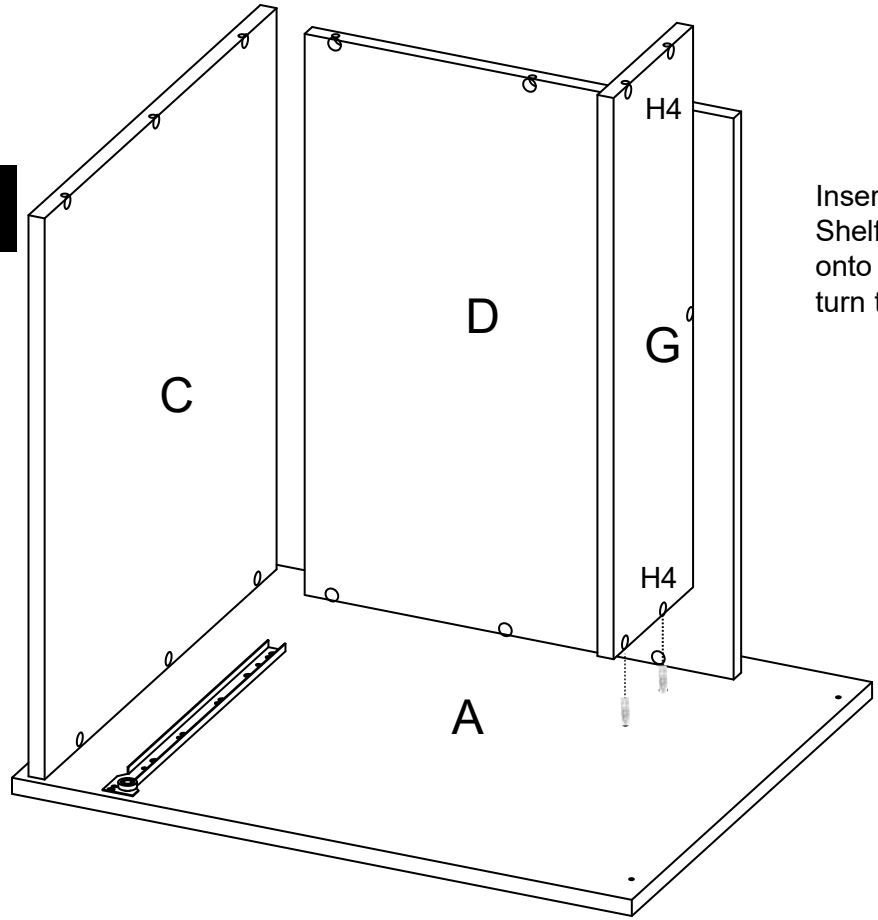

#9

Position the bolts of the Right Side (B) into the corresponding Cams of the partially assembled unit. Turn Cams (H3 and H4) to secure.

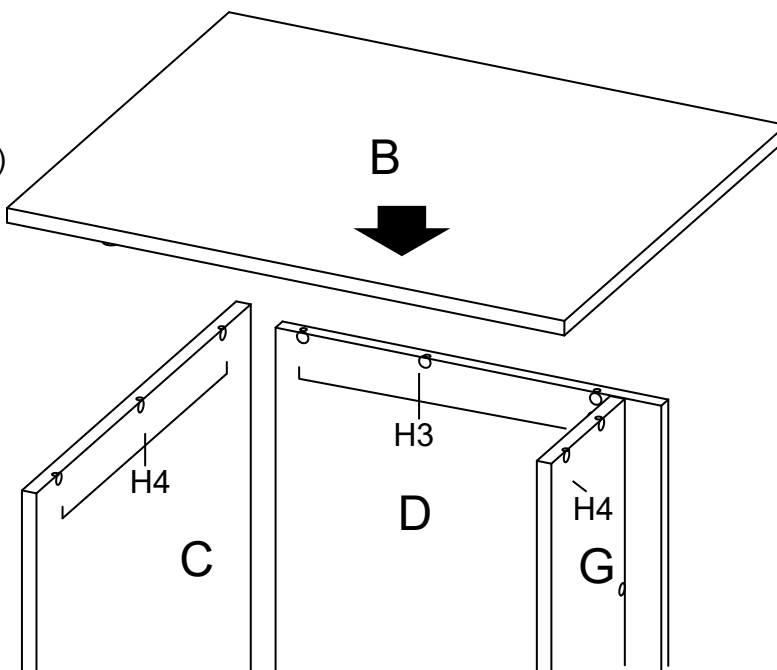

#10

Place 2 Casters on the bottom of both side panels (A and B) and attach by using the included screw that comes with each caster.

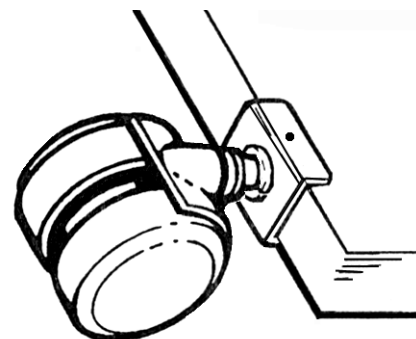

#11

Place the Keyboard Shelf (K) with pre-drilled holes facing up as shown. Attach left and right Shelf Slides (S3 & S4) using the Panhead Screws (H7) as shown.

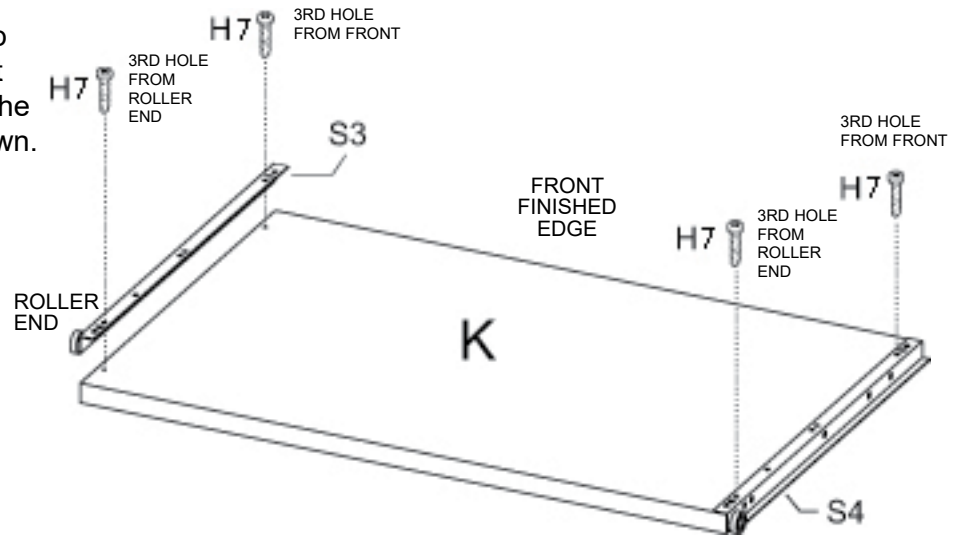

#12

Insert the Keyboard Shelf (K) into the upper set of Side Channels as shown.

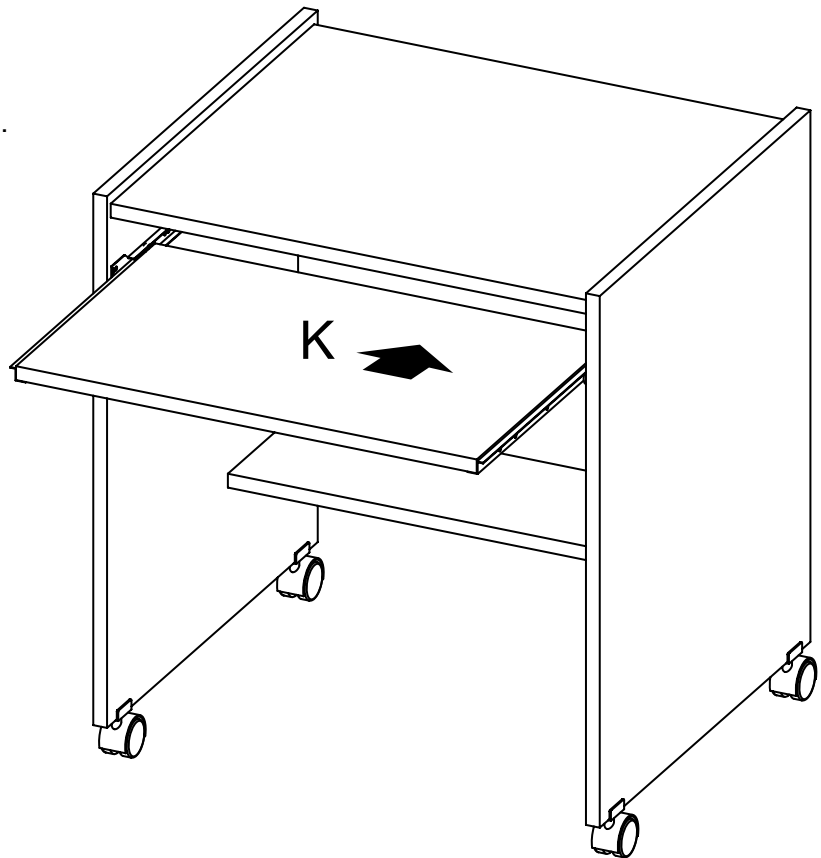

#13

Your CUB Computer Buddy is now completely assembled and ready for use.

