

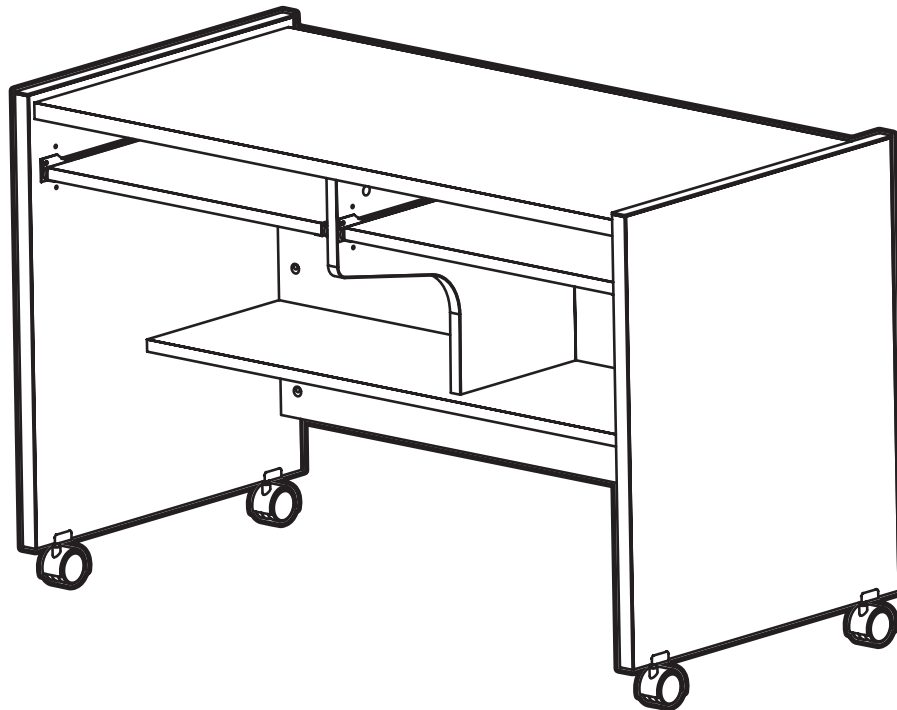

IRONWOOD

BT-48

WORKMATE



IMPORTANT!

Assembly may require the assistance of another person.

Before you begin assembly:

READ THE DIRECTIONS all the way through one time. This will speed up the process and help you understand the sequence of steps.

COUNT THE PARTS AND HARDWARE before assembly. This ensures you have received all necessary parts before you begin.

TOOLS: You may need a Phillips head screwdriver, a medium slotted screwdriver or a plastic mallet. To protect your new furniture from damage during assembly, it is recommended to work on a carpeted surface.

In the event any parts are missing from this package, send your name, address, telephone number, and a description of the missing part(s) to: PARTS, Box 1420, Missoula, MT 59806 or call: 1-800-769-5693 or FAX 1-800-445-5281.

CAUTION: On assemblies requiring glue, make sure the unit is assembled correctly before gluing. Once this unit is assembled with glue, the manufacturer will not be responsible for damaged parts. Keep a damp cloth or sponge handy to wipe off excess glue.

To care for this furniture, simply wipe with a cloth dampened with glass cleaner containing ammonia-D.

PARTS DIAGRAM

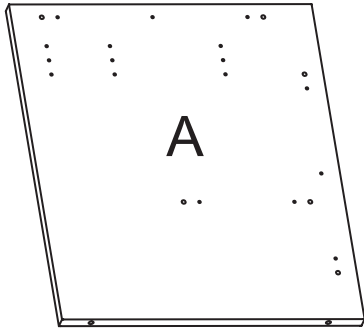

Left Side Panel	03430549
-----------------	----------

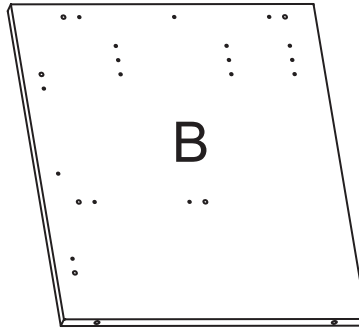

Right Side Panel	03430549
------------------	----------

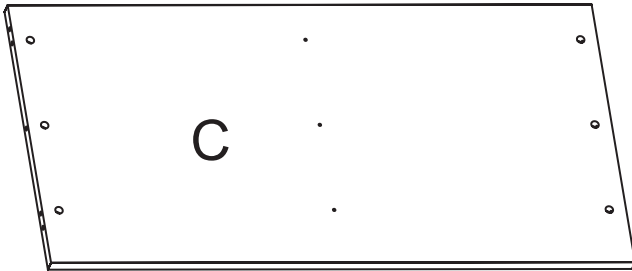

Top	03430541
-----	----------

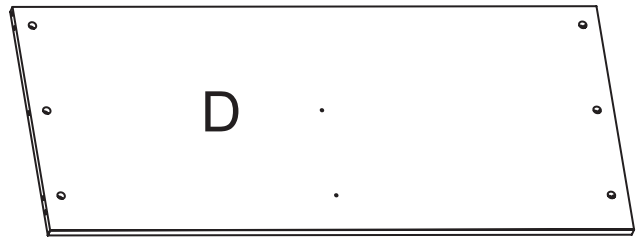

Back	03430541
------	----------



Shelf	03430541
-------	----------

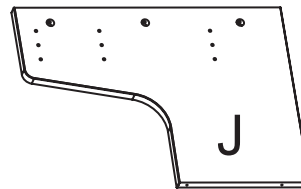

Divider Panel	03430541
---------------	----------

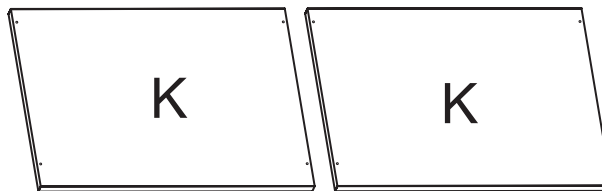

Keyboard Shelf	03432252
----------------	----------

HARDWARE

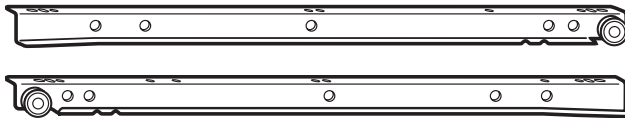

S4

S3

Shelf Slide	490260	2 pr.
-------------	--------	-------

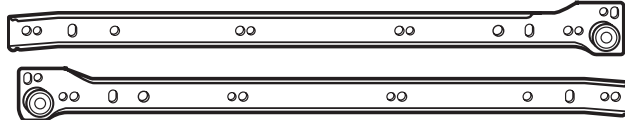

S2

S1

Slide Channel	490260	2 pr.
---------------	--------	-------



H1	Varianta Screw	988060	12 ea.
----	----------------	--------	--------



H2	Minifix Bolt	909834	19 ea.
----	--------------	--------	--------



H3	Wood Dowel	195000	12 ea.
----	------------	--------	--------



H4	Minifix Cam	909810	19 ea.
----	-------------	--------	--------



H5	Confirmat Screw	950100	4 ea.
----	-----------------	--------	-------



H6	Caster Bracket	402302	4 ea.
----	----------------	--------	-------



H7	Caster Socket	402301	4 ea.
----	---------------	--------	-------

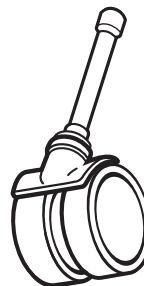

H8	Caster	402290	4 ea.
----	--------	--------	-------



H9	#6x5/8" Panhead Screw	901216	8 ea.
----	-----------------------	--------	-------

Using the Minifix System:

Insert the Minifix Cams into the appropriate holes with the arrow facing outwards as shown.

When screwing post into hole, **Do Not** over tighten. Screw post down until bottom face of post flange just touches board surface.

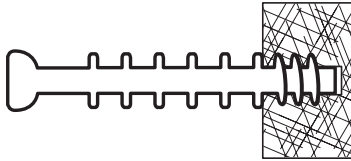

Using the #2 Phillips screwdriver, rotate the Cam Devices a half turn clockwise until snug.

To disassemble, turn the Cam Devices counter-clockwise and remove panels.

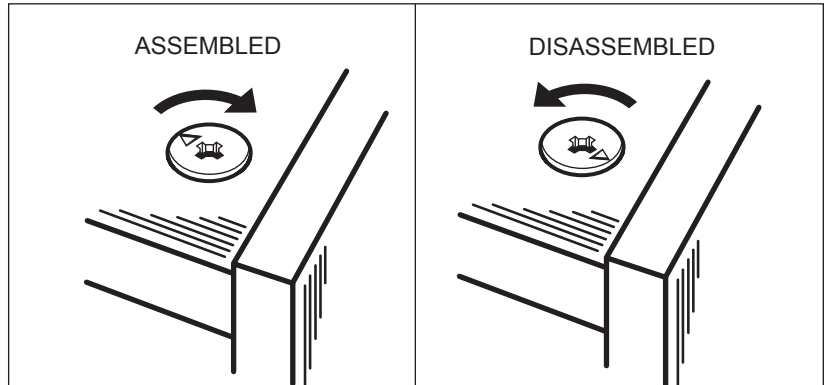
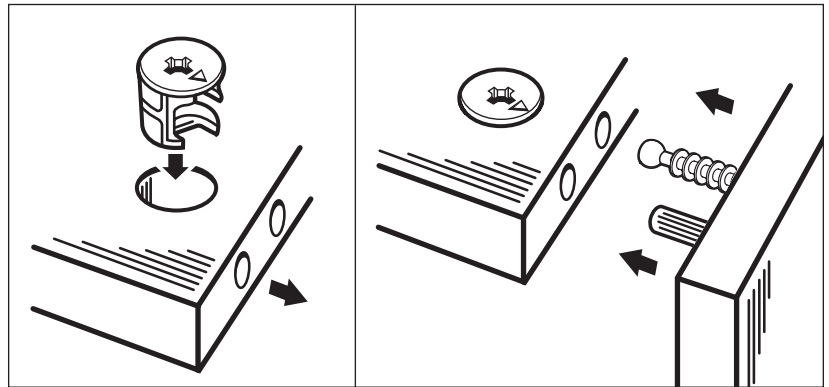

Before starting assembly, select the desired shelf heights.

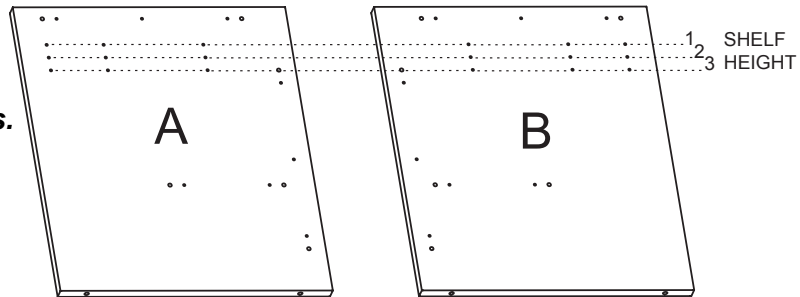

#1 Attach a Left Slide Channel (S1) to the Left Side Panel (A) using three Varianta Screws (H1) in the selected pre-drilled holes as shown.

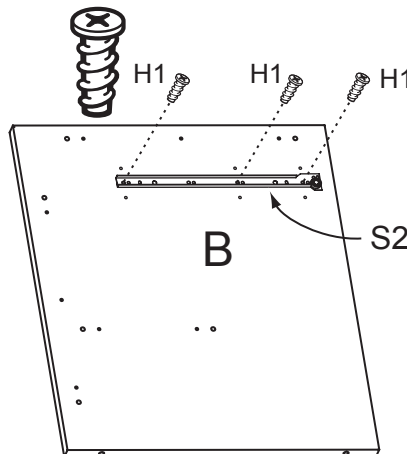
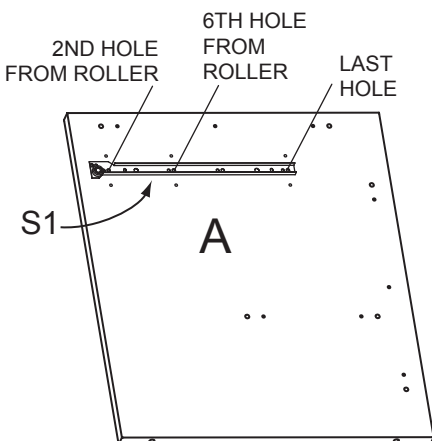
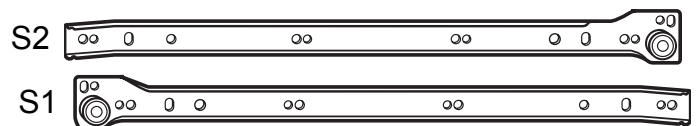

#2

Attach a Right Slide Channel (S2) to the Right Side Panel (B) using three Varianta Screws (H1) in the selected pre-drilled holes as shown.

#3

Place the Divider Panel (J) as shown below and attach a Left Slide Channel (S1) using three Varianta Screws (H1).

Attach a Right Slide Channel to the other side of the divider, opposite the Left Slide Channel.

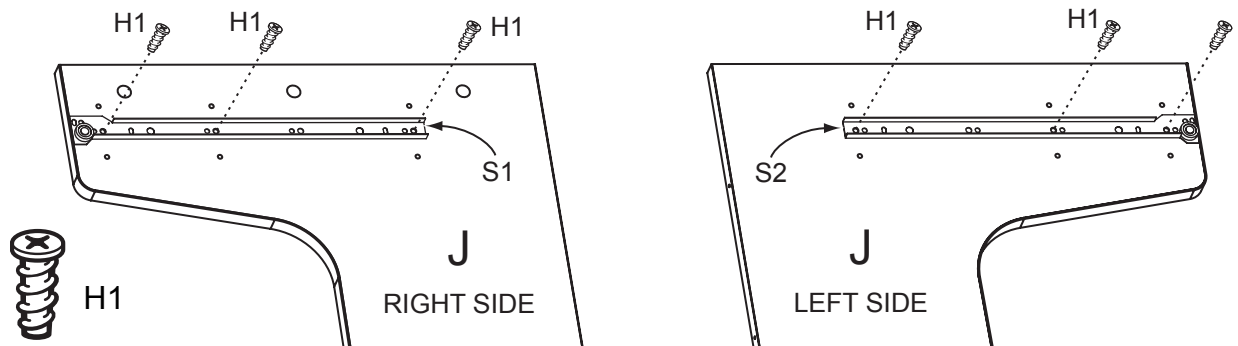
**#4**

Screw eight Minifix Bolts (H2) into the pre-drilled holes of the Right Side Panel (B) and Left Side Panel (A) where indicated.

Screw three Minifix Bolts (H2) into the pre-drilled holes of the Top (C) where indicated.

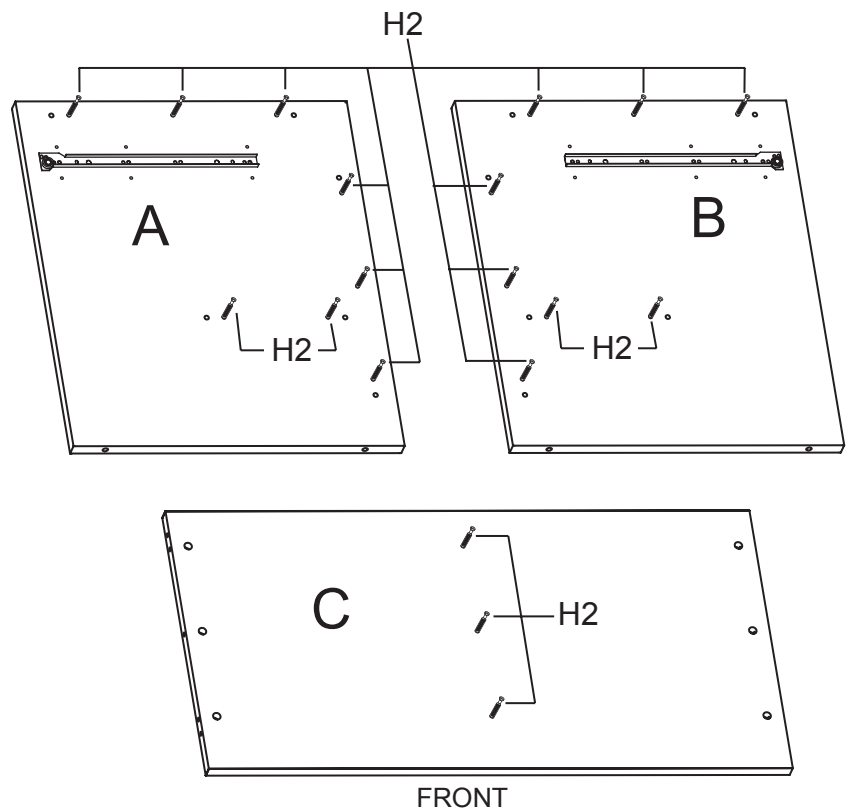
**#5**

Insert six Wood Dowels (H3) into the pre-drilled holes of the Right Side Panel (B) and the Left Side Panel (A) and tap lightly into place as shown.

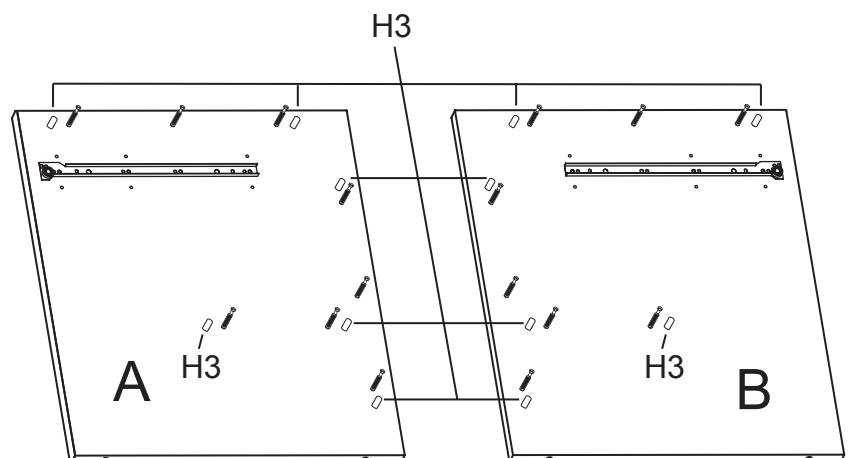

#6a

Insert six Minifix Cams (H4) into the Top Panel (C) with the arrows of the cams facing out.

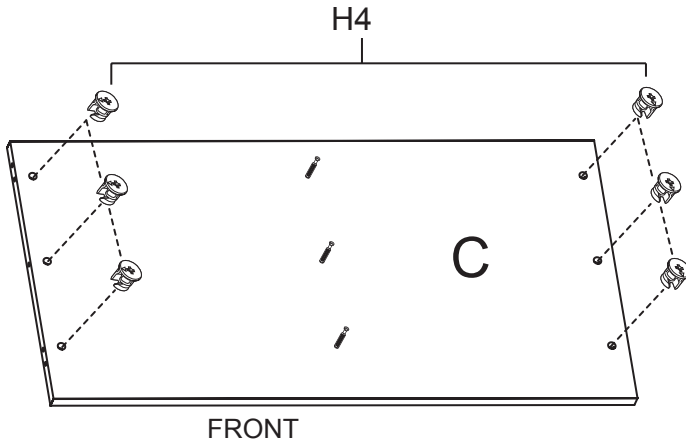

#7a

Insert three Minifix Cams (H4) into the Divider Panel (J) with the arrows of the cams facing out.

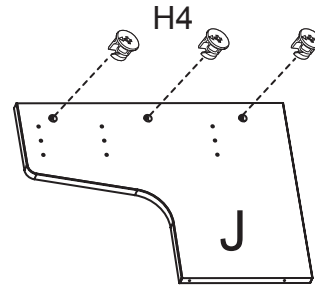

#7b

Position the Divider Panel onto the Top Panel (C) and turn the Minifix Cams to secure.

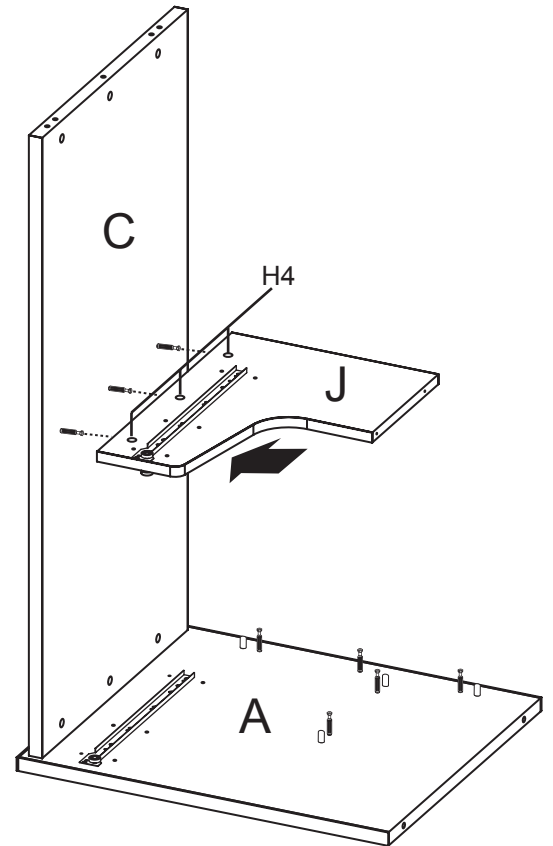

#6b

Position the Top Panel onto the Left Side Panel (A) and turn the Minifix Cams clockwise to secure.

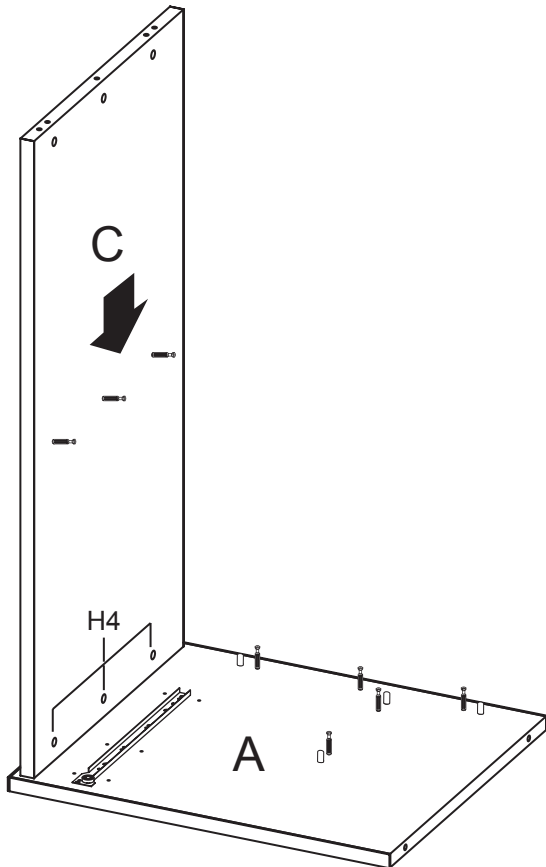

#8a

Insert six Minifix Cams (H4) into the Back Panel (D) with the arrows of the cams facing out.

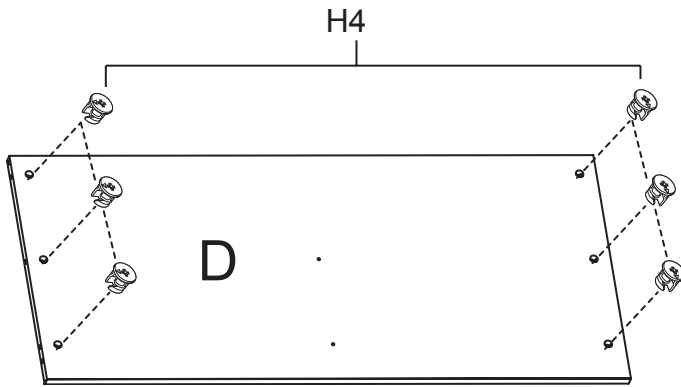

#8b

Position the Back Panel (D) onto the Side Panel (A) and turn the Minifix Cams clockwise to secure.

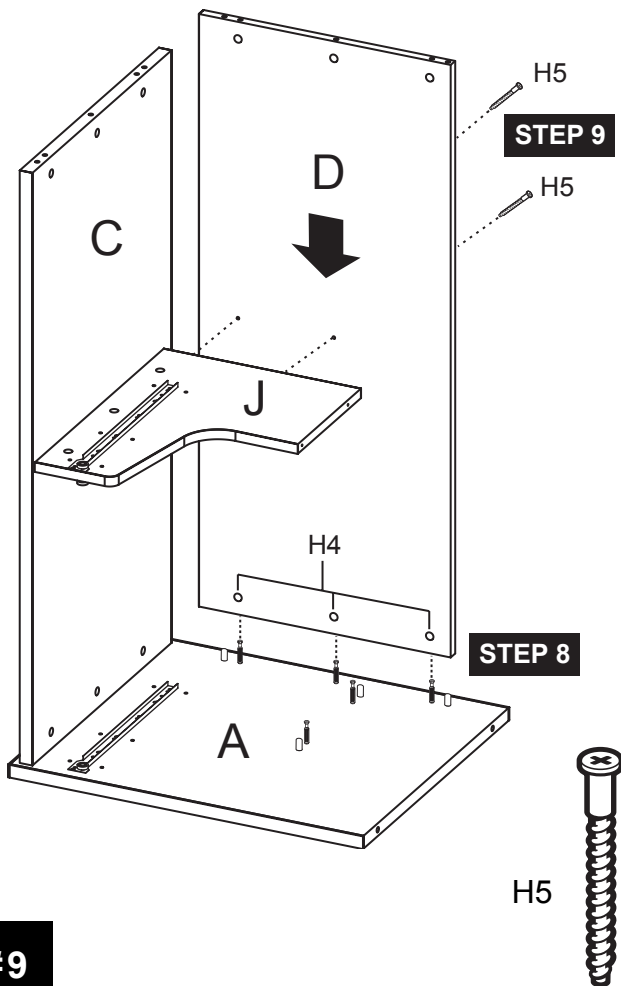

#9

Secure the Divider Panel (J) to the Back Panel (D) using two Confirmat Screws (H5) as shown.

#10a

Insert four Minifix Cams into the Shelf (G) with the arrows of the cams facing outwards.

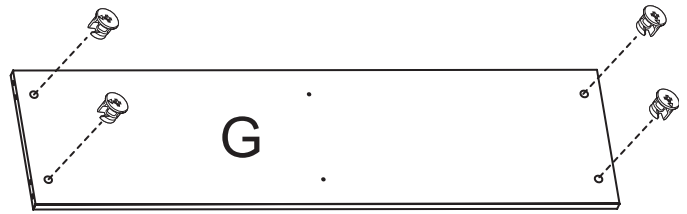

#10b

Position Shelf onto the Left Side Panel (A) and turn cams clockwise to secure.

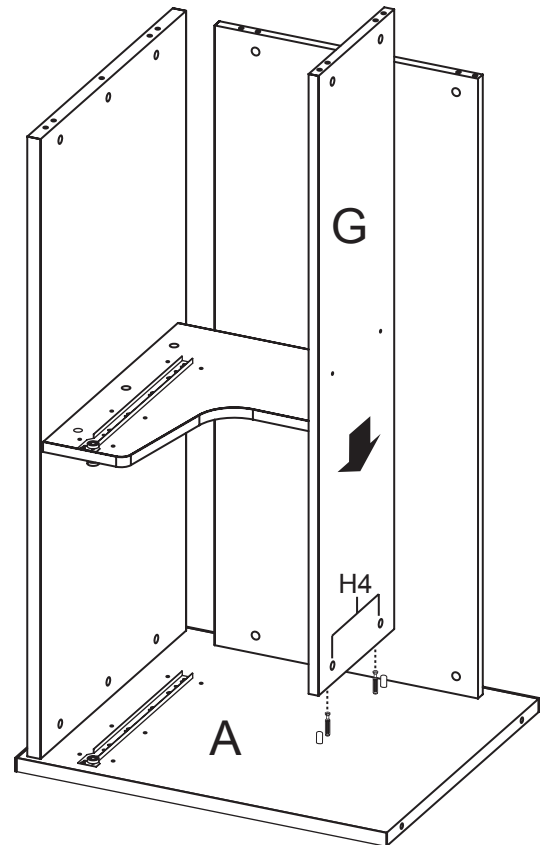

#11

Secure the Shelf to the Divider Panel (J) using two Confirmat Screws (H5) as shown.

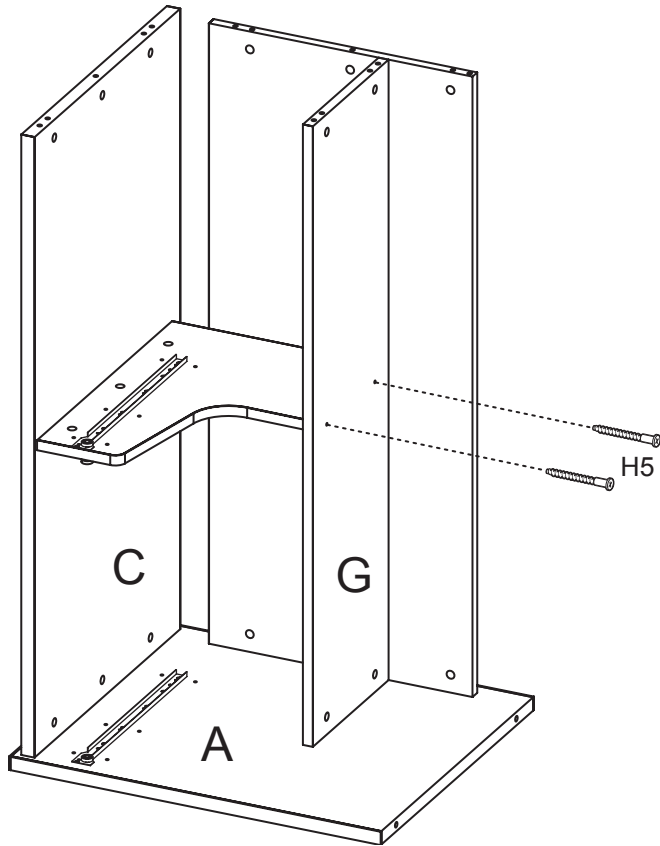
**#12**

Position Right Side Panel (B) over the partially assembled unit insuring that the Minifix Bolts and Wood Dowels are inserted into the corresponding Minifix Cams and holes as shown.

Rotate the eight Minifix Cams (H4) clockwise to lock the Right Side Panel into place.

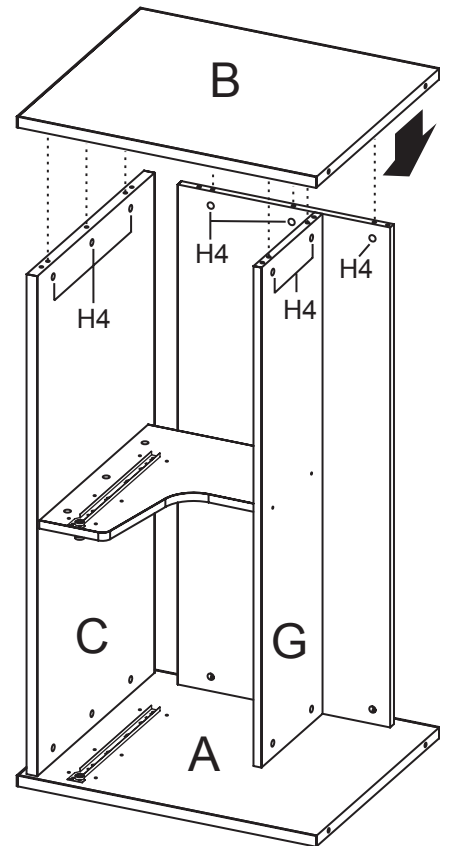
**#13**

Position the Caster Brackets (H6) over the corresponding holes in the bottom edges of the Side Panels. Insert Caster Sockets (H7) into the holes and tap until bottomed out against the Caster Brackets.

Insert the Casters (H8) into the Caster Sockets and tap into place.

With the assistance of another person, turn the unit upright.

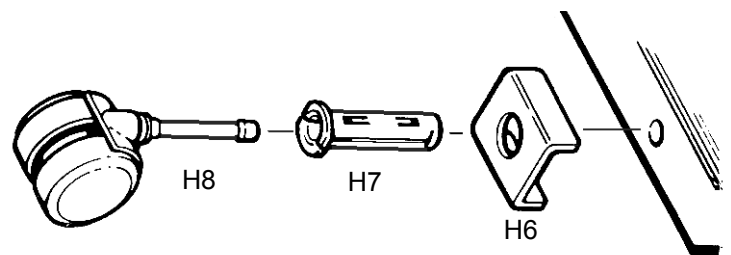

The locking casters should be positioned on the front of the unit.

#14

Place both Keyboard Shelves (K) with the pre-drilled holes facing up. Attach Left and Right Shelf Slides (S3&S4) using the Panhead Screws (H9) as shown.

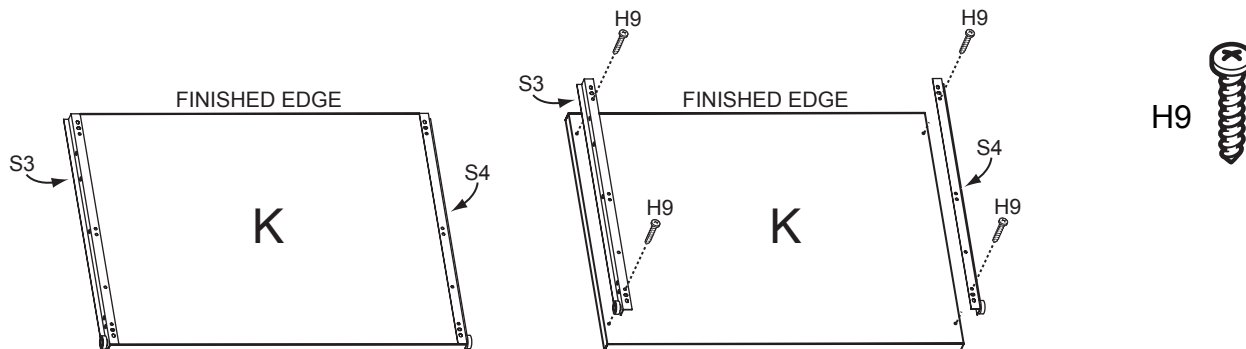
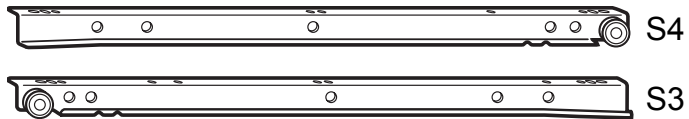
**#15**

With the unit upright, slide the Keyboard Shelves (G) into the Shelf Slides as shown.

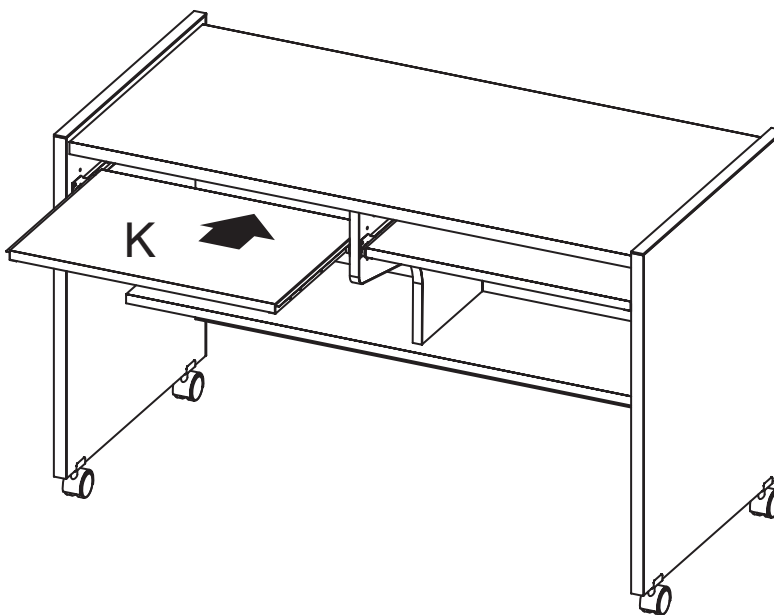

Your Ironwood Workmate is now completely assembled and ready for use.