

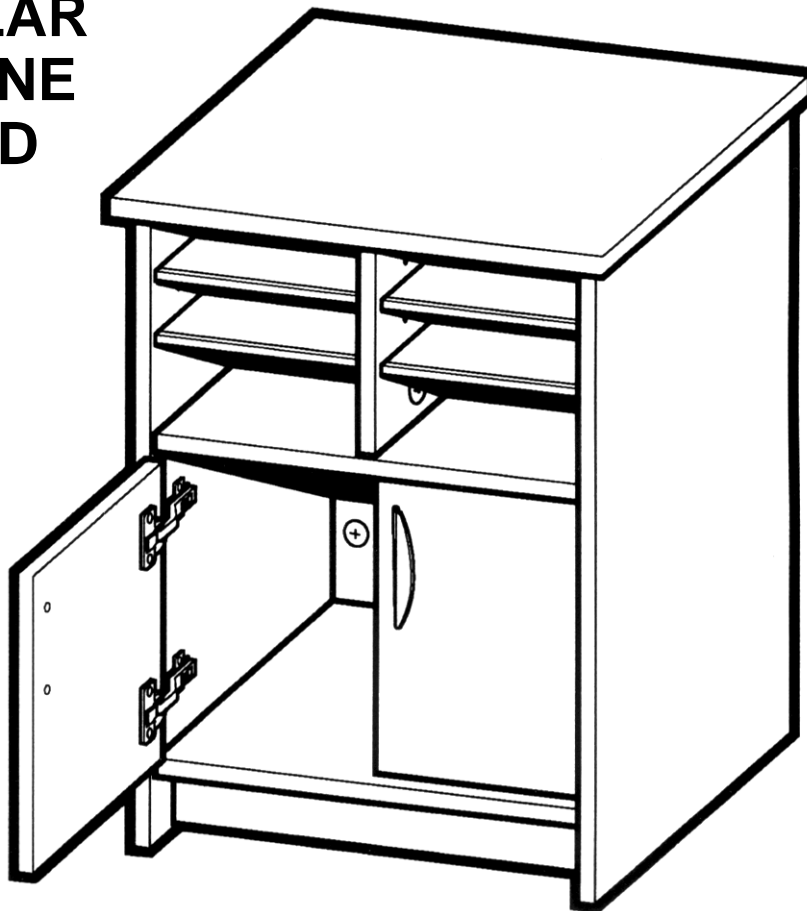

MMS

MODULAR MACHINE STAND



IMPORTANT!

Assembly may require the assistance of another person.

Before you begin assembly:

READ THE DIRECTIONS all the way through one time. This will speed up the process and help you understand the sequence of steps.

COUNT THE PARTS AND HARDWARE before assembly. This ensures you have received all necessary parts before you begin.

TOOLS: You may need a Phillips head screwdriver, a medium slotted screwdriver or a plastic mallet. To protect your new furniture from damage during assembly, it is recommended to work on a carpeted surface.

In the event any parts are missing from this package, send your name, address, telephone number, and a description of the missing part(s) to: PARTS, Box 1420, Missoula, MT 59806 or call: 1-800-769-5693 or FAX 1-800-445-5281.

CAUTION: On assemblies requiring glue, make sure the unit is assembled correctly before gluing. Once this unit is assembled with glue, the manufacturer will not be responsible for damaged parts. Keep a damp cloth or sponge handy to wipe off excess glue.

To care for this furniture, simply wipe with a cloth dampened with glass cleaner containing ammonia-D.

PARTS DIAGRAM

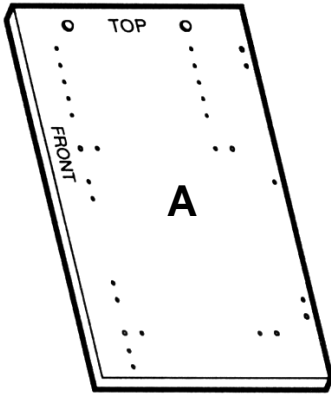

Left Side Panel	02360241	1 ea.
-----------------	----------	-------

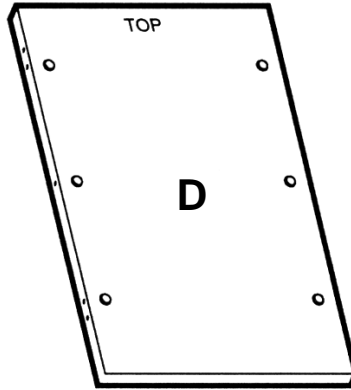

Back Panel	02360252	1 ea.
------------	----------	-------

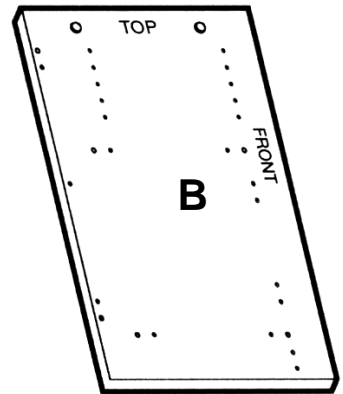

Right Side Panel	02360241	1 ea.
------------------	----------	-------

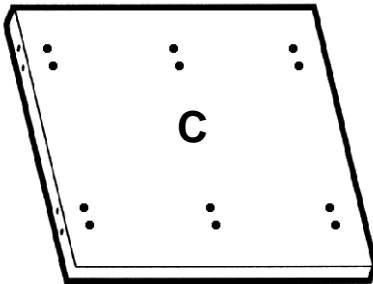

Top Panel	02360201	1 ea.
-----------	----------	-------

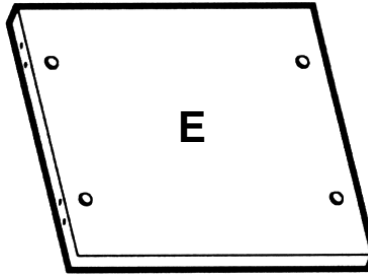

Bottom Panel	02360211	1 ea.
--------------	----------	-------

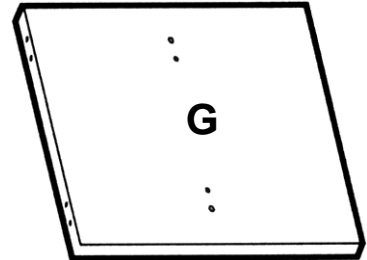

Fixed Shelf	02360221	1 ea.
-------------	----------	-------

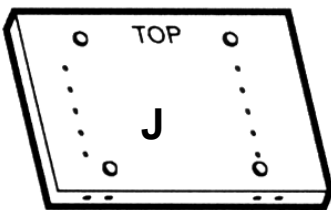

Divider Panel	02360244	1 ea.
---------------	----------	-------

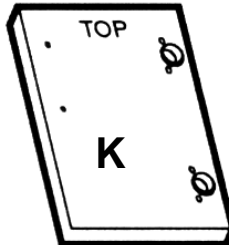

Left Door	02360273	1 ea.
-----------	----------	-------

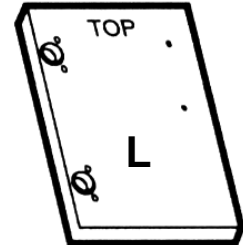

Right Door	02360273	1 ea.
------------	----------	-------

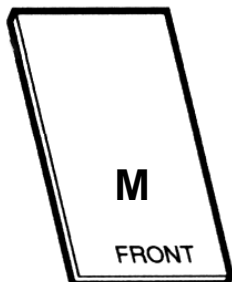

Adjustable Shelf	02360224	4 ea.
------------------	----------	-------



Toe Board	02360272	1 ea.
-----------	----------	-------

HARDWARE



H1	Minifix Cam	909810	22 ea.
----	-------------	--------	--------



H2	Minifix Bolt	909834	22 ea.
----	--------------	--------	--------



H3	Wood Dowel	195000	20 ea.
----	------------	--------	--------



H4	Door Bumper	298030	2 ea.
----	-------------	--------	-------

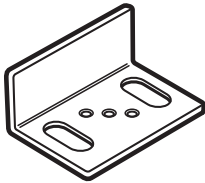

H5	Slotted Angle Bracket	401174	1 ea.
----	-----------------------	--------	-------



H6	Small Panhead Screw	901206	2 ea.
----	---------------------	--------	-------

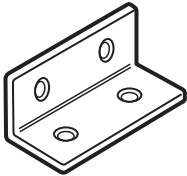

H7	Angle Bracket	401170	2 ea.
----	---------------	--------	-------



H8	Varianta Screw	988060	8 ea.
----	----------------	--------	-------

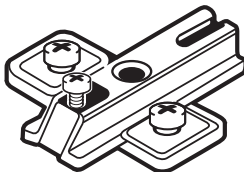

H9	Hinge Plate	400207	4 ea.
----	-------------	--------	-------

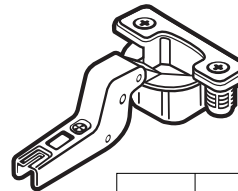

H10	Hinge	400205	4 ea.
-----	-------	--------	-------



H11	Door Handle	400800	2 ea.
-----	-------------	--------	-------



H12	1" Machine Screw	901314	4 ea.
-----	------------------	--------	-------



H13	Label Holder Moulding	H3404	4 ea.
-----	-----------------------	-------	-------

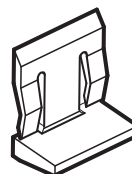

H14	Shelf Support Pin	297211	16 ea.
-----	-------------------	--------	--------

Using the Minifix System:

Insert the Minifix Cams into the appropriate holes with the arrow facing outwards as shown.

When screwing post into hole, **Do Not** over tighten. Screw post down until bottom face of post flange just touches board surface.

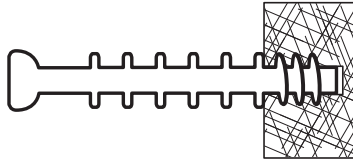

Using the #2 Phillips screwdriver, rotate the Cam Devices a half turn clockwise until snug.

To disassemble, turn the Cam Devices counter-clockwise and remove panels.

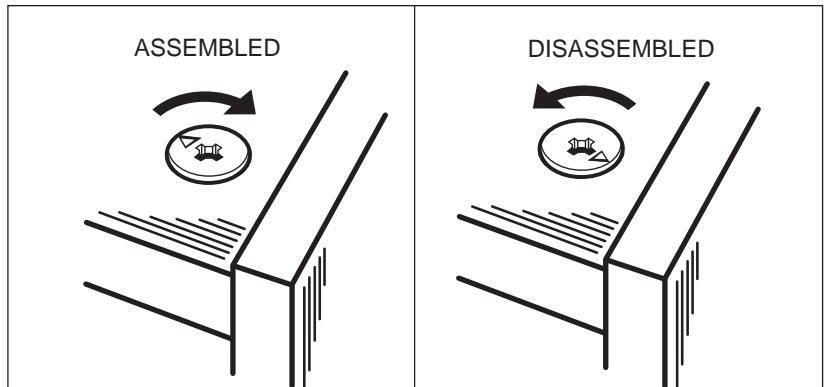
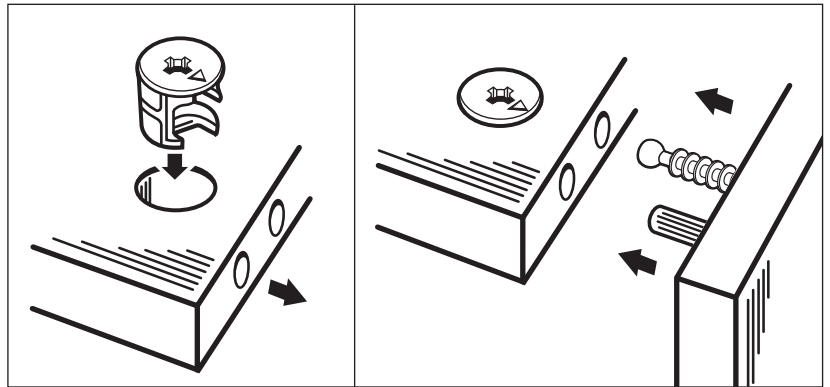

#1

Place the Fixed Shelf (G), Bottom (E), and Divider (J) on a clean, carpeted surface with the cam holes upright as shown. Insert Minifix Cams (H1) into the Fixed Shelf, Bottom, and Divider where indicated with the arrows of the cams facing out.

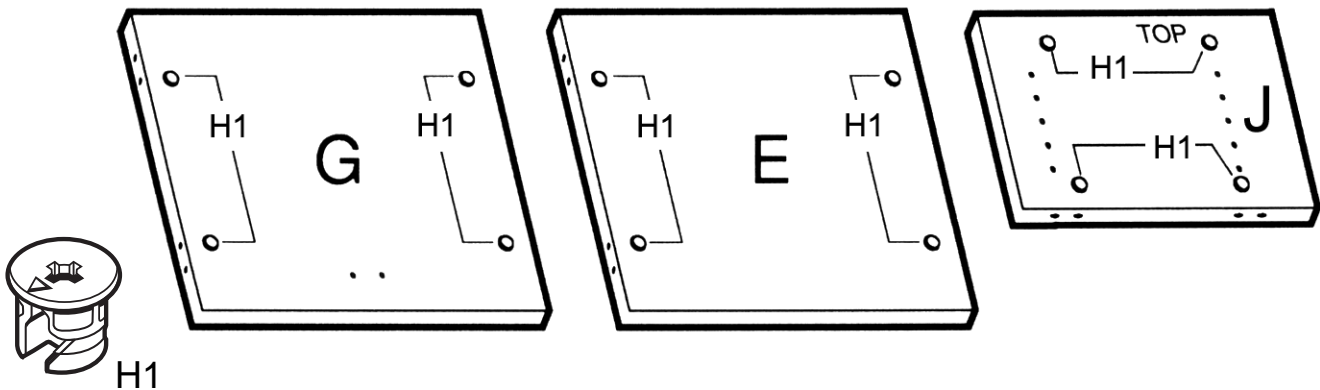

#2

Screw six Minifix Bolts (H2) and insert six Dowels (H3) into the pre-drilled holes of the Top (C) where indicated.

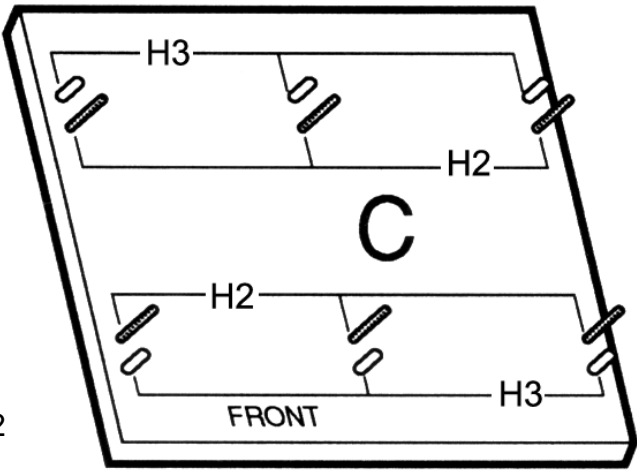
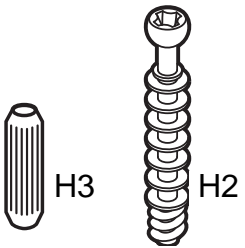

#3

Remove the backing from the adhesive side of the Door Bumpers (H4) and press onto the Slotted Angle Bracket (H5) as shown.

Attach the Slotted Angle Bracket to the underside of the Fixed Shelf (G) using two #6x1/2" Panhead Screws (H6) as shown.

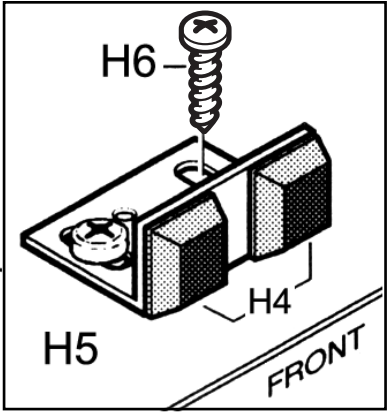
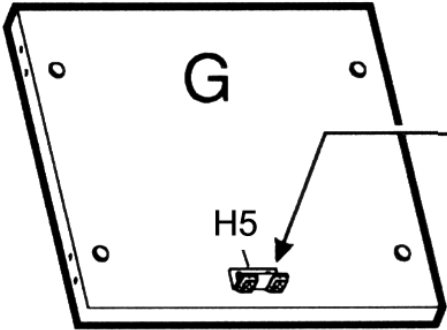

#4

Turn the Fixed Shelf (G) over. Screw two Minifix Bolts (H2) and insert two Dowels (H3) into the pre-drilled holes of the Fixed Shelf where indicated.

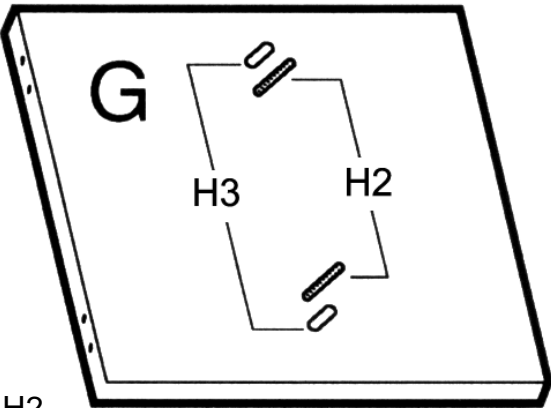
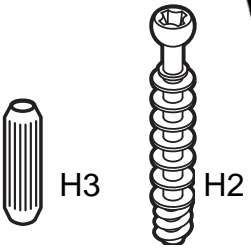

#5

Secure an Angle Bracket (H7) to each end of the Toeboard (F) using four Varianta Screws (H8).

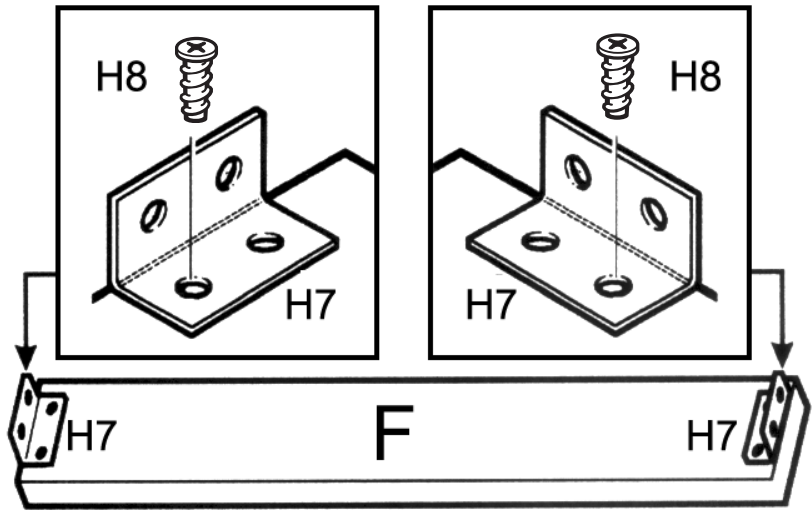

#6

Screw seven Minifix Bolts (H2) and insert six Wood Dowels (H3) into the Side Panels (A & B) where indicated.

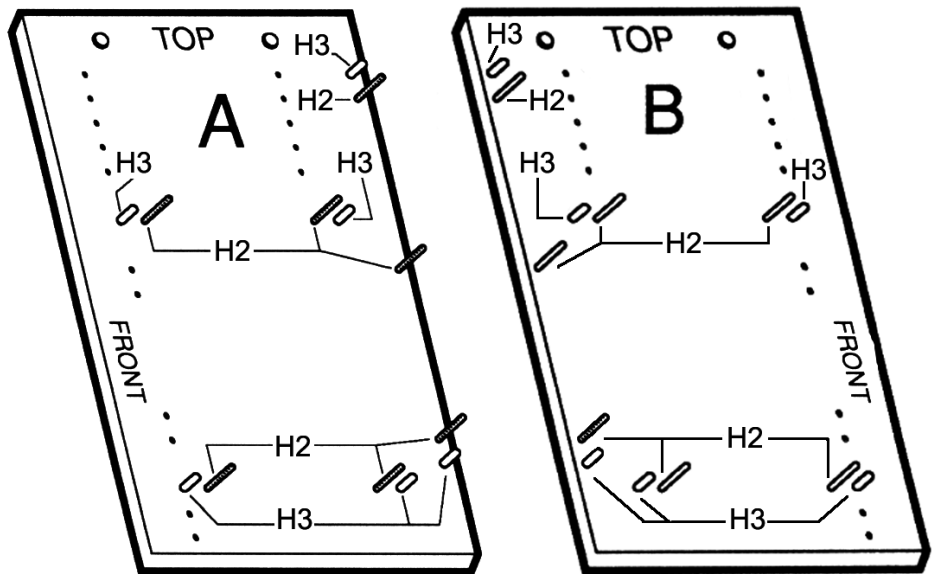
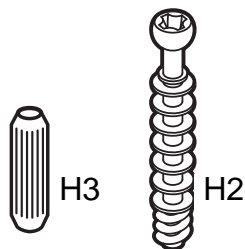

#7

Insert two Minifix Cams (H1) into the Side Panels (A & B) with the arrows of the cams facing out.

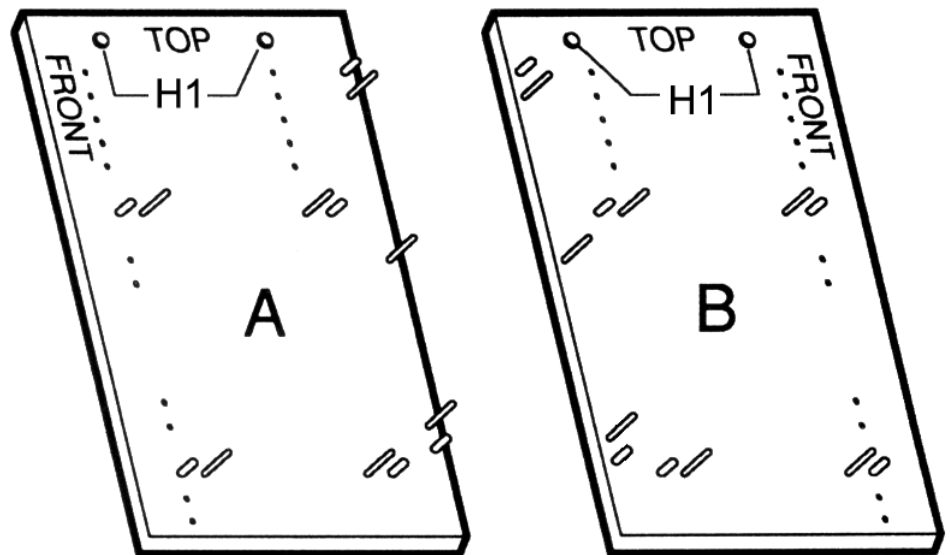

#8

Attach the Hinge Plates (H9) to the Left Side (A) and Right Side (B) using the attached screws into the pre-drilled holes where indicated.

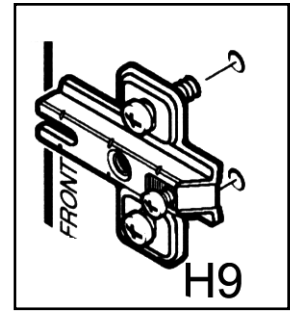
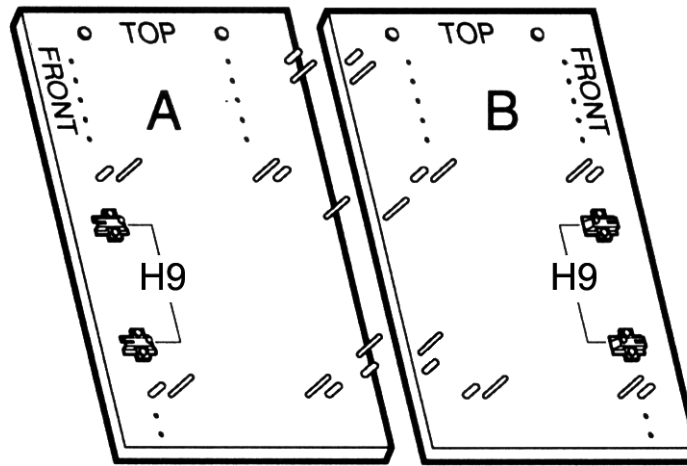

#9

Insert six Minifix Cams (H1) into the Back (D) with the arrows of the cams facing out.

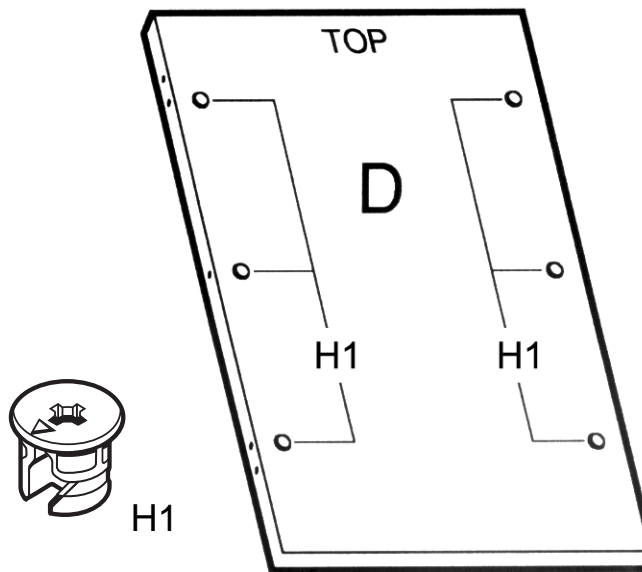

#10

Position the Back (D) onto the Left Side (A). Turn the cams (H1) clockwise to secure.

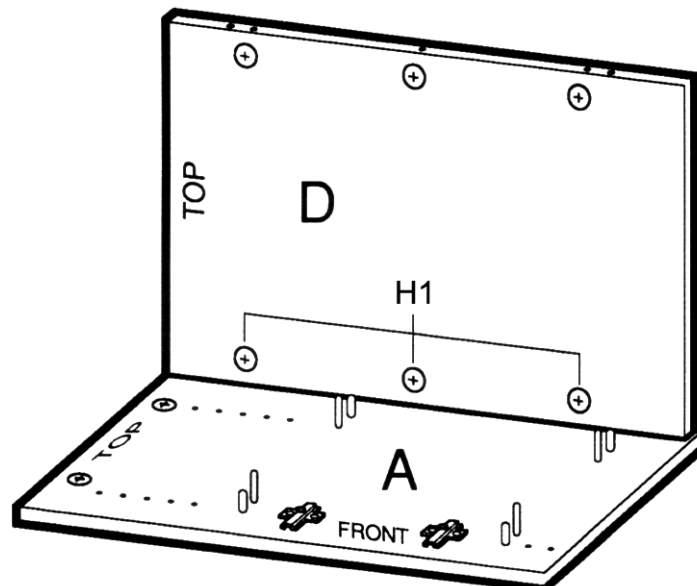

#11

Position the Fixed Shelf (G) onto the Left Side (A) and turn cams (H1) clockwise to secure.

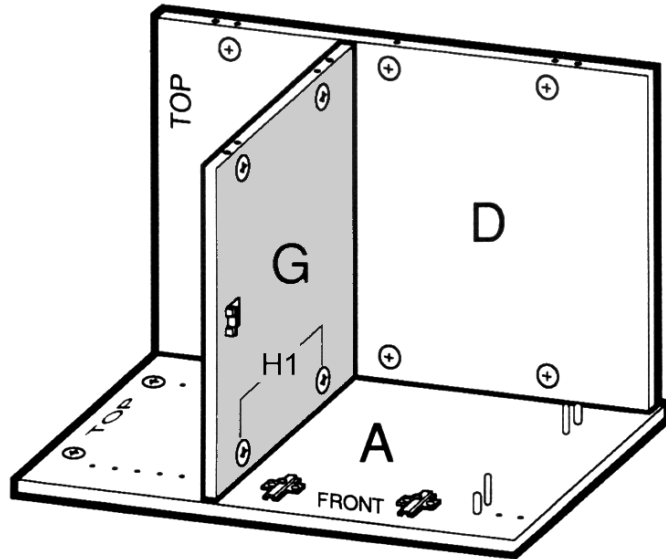

#12

Position the Bottom (E) onto the Left Side (A). Turn the cams (H1) clockwise to secure.

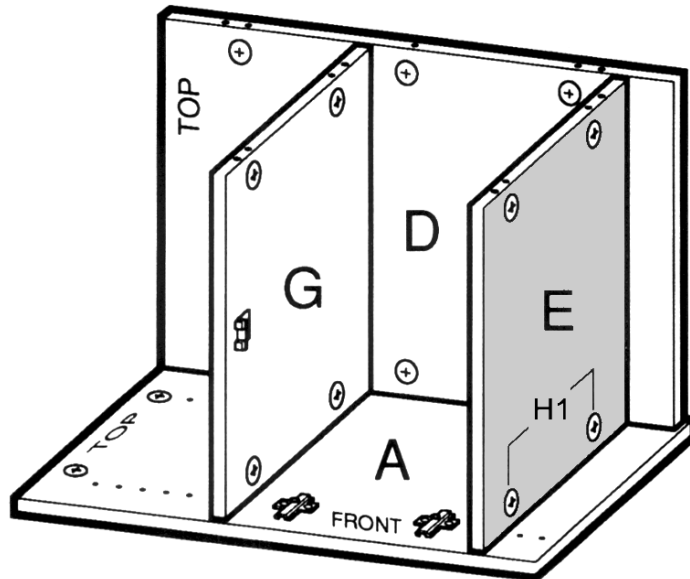

#13

Position the Toeboard (F) onto the Left Side (A) and secure in place using two Varianta Screws (H8) through the Angle Bracket (H7) into the pre-drilled holes.

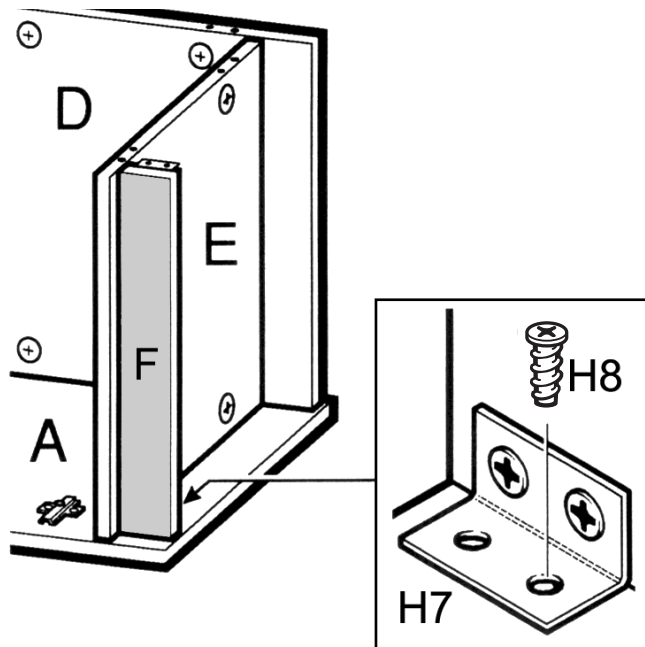

#14

Position the bolts and dowels of the Right Side (B) onto the unit and turn cams (H1) clockwise to lock in place.

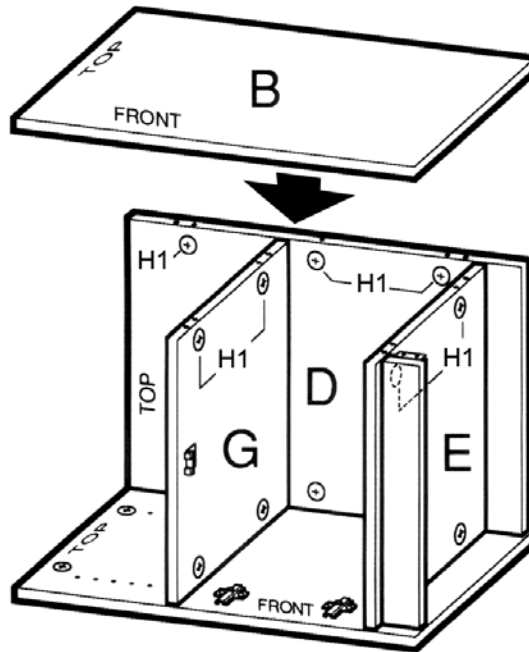

#15

Secure the upper Angle Bracket (H7) of the Toeboard (F) to the Right Side (B) using two Varianta Screws (H8) as shown.

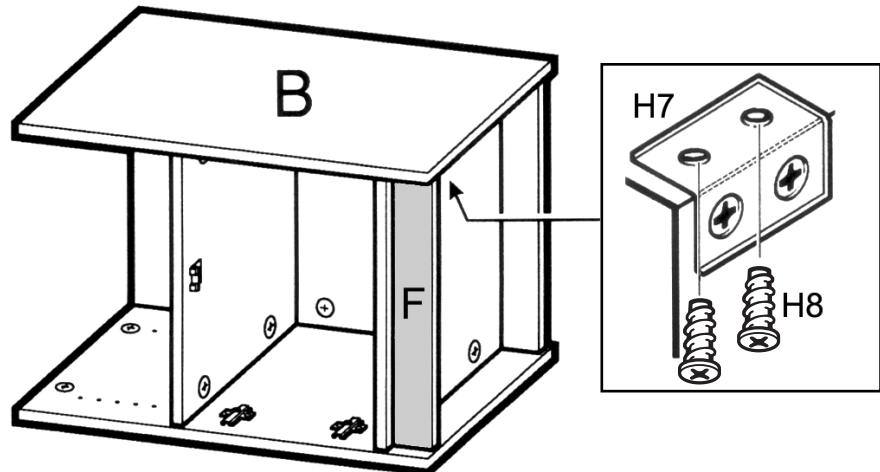

#16

Stand the unit upright. Position the Divider (J) with the top edge as shown onto the Fixed Shelf (G). Turn the cams (H1) of the Divider Panel clockwise to secure in place.

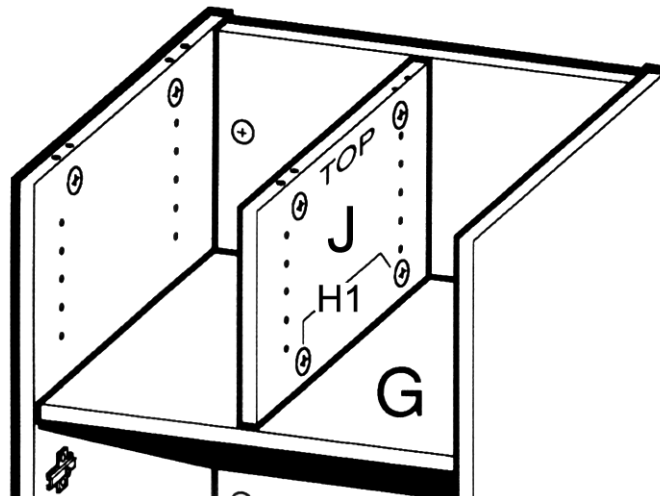

#17

Position the bolts and dowels of the Top (C) onto the assembled unit, making sure the front edge is as shown. Turn the cams (H1) of the Left Side (A), Divider (J), and Right Side (B) clockwise to lock in place.

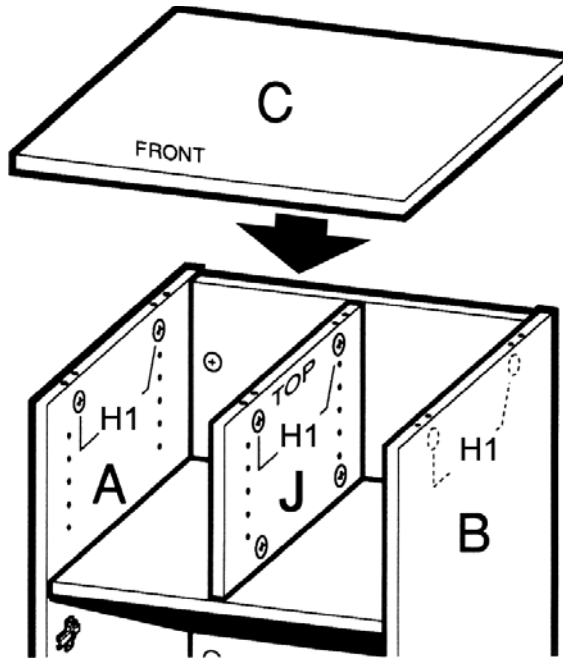

#18

Press Hinges (H10) into the corresponding holes in the Left Door (N) and the Right Door (L). Tap into place. Tighten the screws of each Hinge (H10) to secure in place.

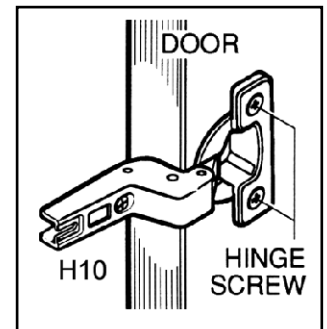

#19

Attach a Door Handle (H11) to the Left Door (N) and the Right Door (L) using four 1" Machine Screws (H12) as shown.

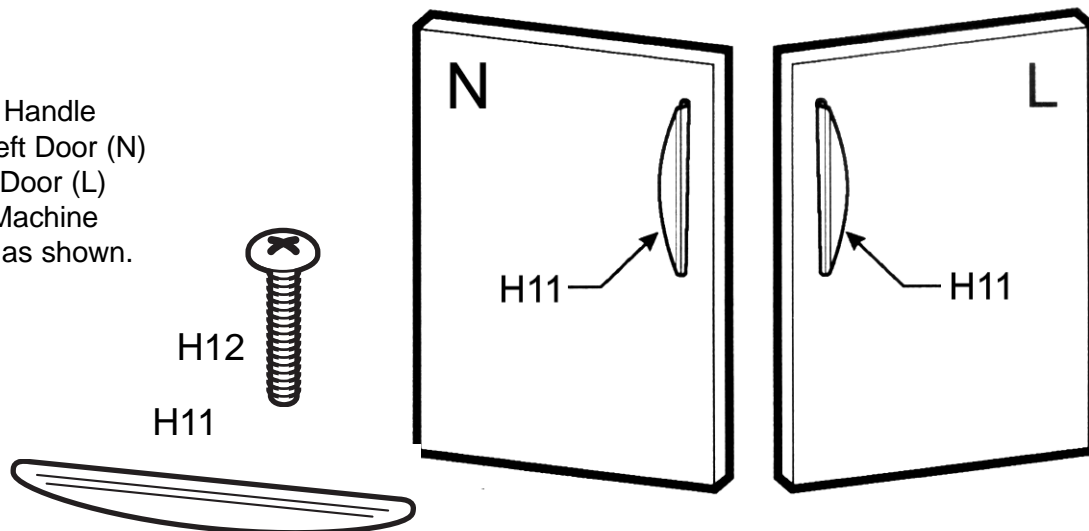

#20

To attach the Left Door (N) to the unit, slide the door Hinges (H10) onto the Hinge Plates (H9) as shown. Tighten the center screw.

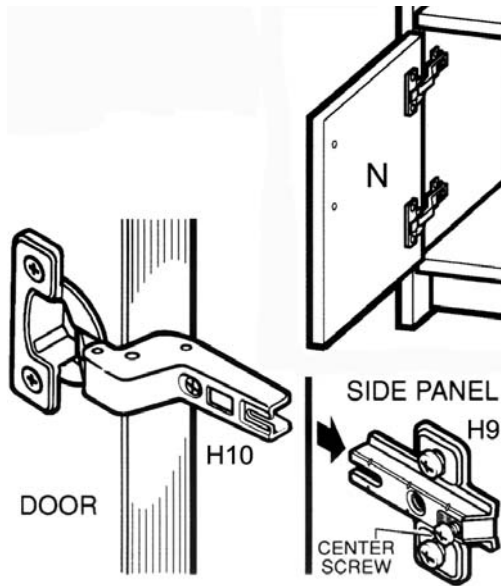
**#21**

To attach the Right Door (L) to the unit, slide the door Hinges (H10) onto the Hinge Plates (H9) as shown. Tighten the center screw.

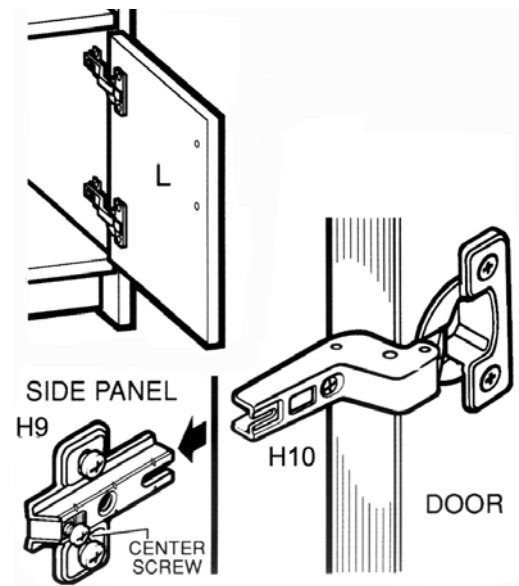
**#22**

Follow these steps for proper door alignment:

Step A: Loosen the screws of the hinge plates for UP and DOWN adjustment. Retighten screws after proper adjustment is made.

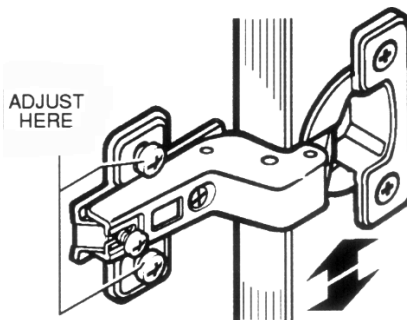

Step B: Loosen the center screw of the hinge plate for IN and OUT adjustment. Retighten center screw after proper adjustment is made..

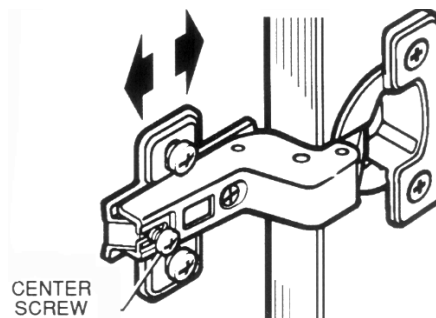

Step C: To adjust the gap between the doors, turn this screw. For a smaller gap between the doors, turn the screw clockwise. For a larger gap between the doors, turn the screw counter-clockwise.

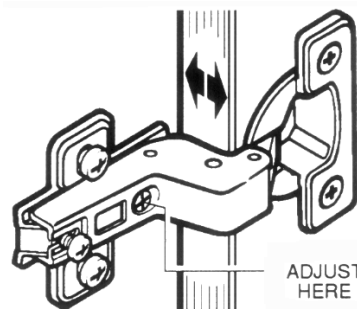

#23

Press a Label Holder Molding (H13) onto a short edge of each of the Adjustable Shelves (M) as shown.

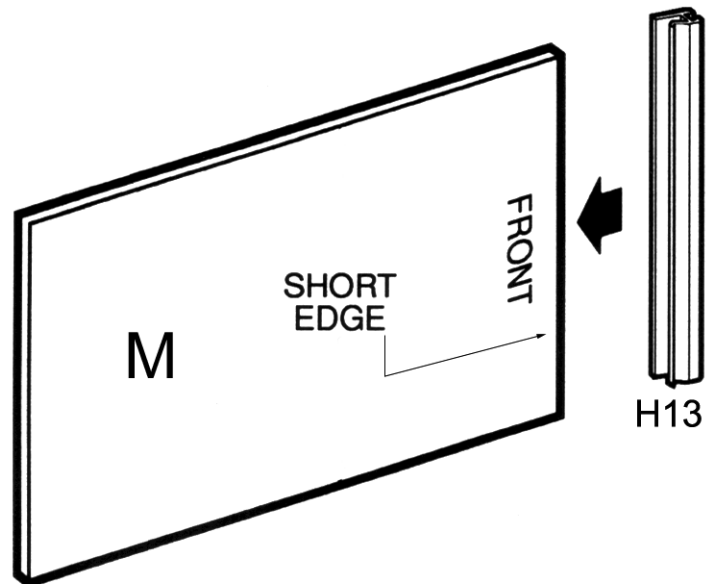

#24

Determine the height for the placement of the Adjustable Shelves (M). Insert Shelf Support Pins (H14) into the pre-drilled holes of the Left Side (A), both sides of the Divider (J), and the Right Side (B) as shown.

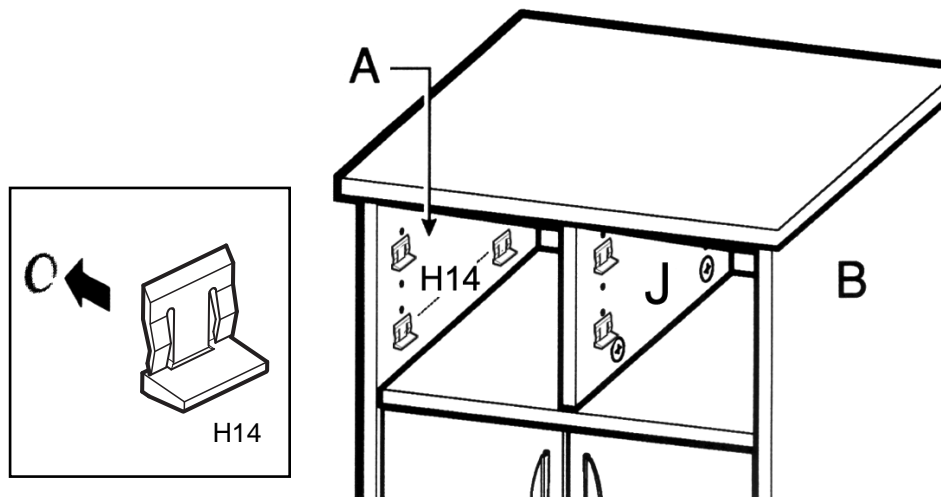

#25

Place the Adjustable Shelves (M) onto the Shelf Support Pins as shown. The front (label) edge of the Adjustable Shelves should be positioned as shown.

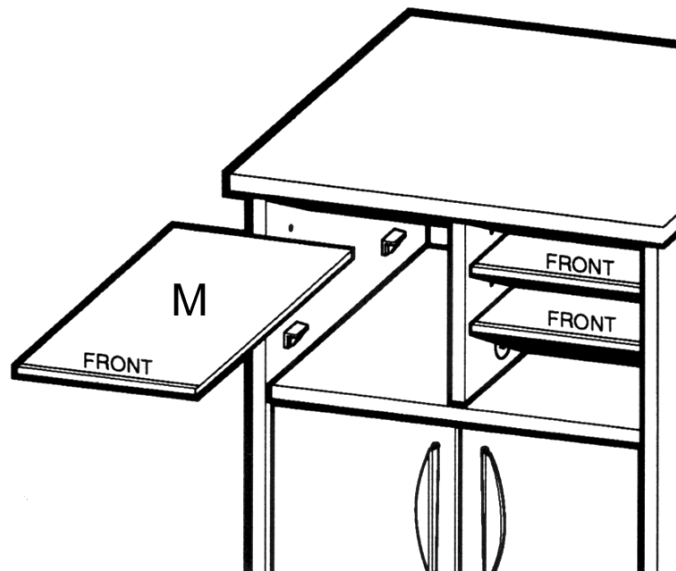

Assembly of the Modular Machine Stand is now complete.