

---

# KIT24

---

## TRANSITION ATTACHMENT

*The 24" Desk Shell can be joined to either end of a 24" or a 30" Desk Shell. Be sure to select and remove the appropriate side panel of the selected Desk Shell to match your preference.*

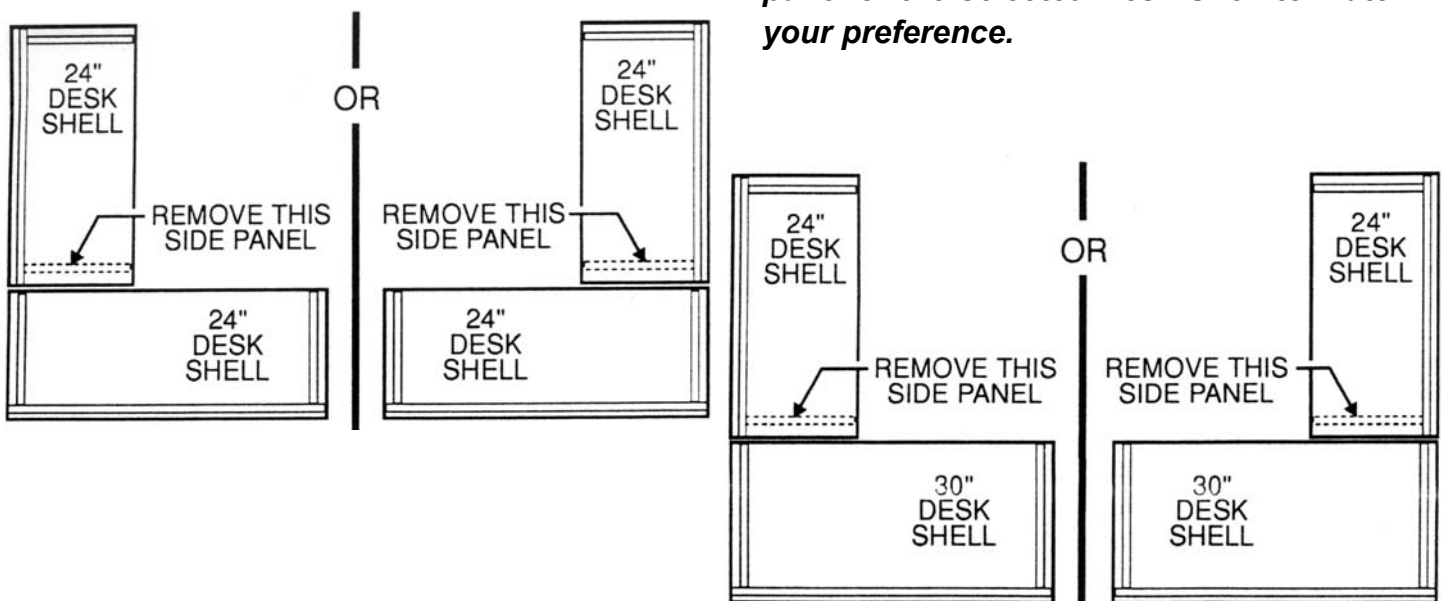

### IMPORTANT!

**Assembly may require the assistance of another person.**

**Before you begin assembly:**

**READ THE DIRECTIONS** all the way through one time. This will speed up the process and help you understand the sequence of steps.

**COUNT THE PARTS AND HARDWARE** before assembly. This ensures you have received all necessary parts before you begin.

**TOOLS:** You may need a Phillips head screwdriver, a medium slotted screwdriver or a plastic mallet. To protect your new furniture from damage during assembly, it is recommended to work on a carpeted surface.

In the event any parts are missing from this package, send your name, address, telephone number, and a description of the missing part(s) to: **PARTS, Box 1420, Missoula, MT 59806** or call: **1-800-769-5693** or **FAX 1-800-445-5281**.

**CAUTION:** On assemblies requiring glue, make sure the unit is assembled correctly before gluing. Once this unit is assembled with glue, the manufacturer will not be responsible for damaged parts. Keep a damp cloth or sponge handy to wipe off excess glue.

To care for this furniture, simply wipe with a cloth dampened with glass cleaner containing ammonia-D.

# PARTS DIAGRAM



H1	18" Connector Plate	411270	1 ea.
----	---------------------	--------	-------



H2	#8 x 5/8" Panhead Screw	988056	16 ea.
----	-------------------------	--------	--------



H3	Transition Bracket	Black 411570 Gray 411532	1 ea.
----	--------------------	-----------------------------	-------



H2	#8 x 5/8" Panhead Screw	Black 988056 Gray 988054	6 ea.
----	-------------------------	-----------------------------	-------

## #1

Turn the Minifix Cams (M) along the top edge of the Side Panels and Back Panel counterclockwise to loosen the Top. Remove the Top.

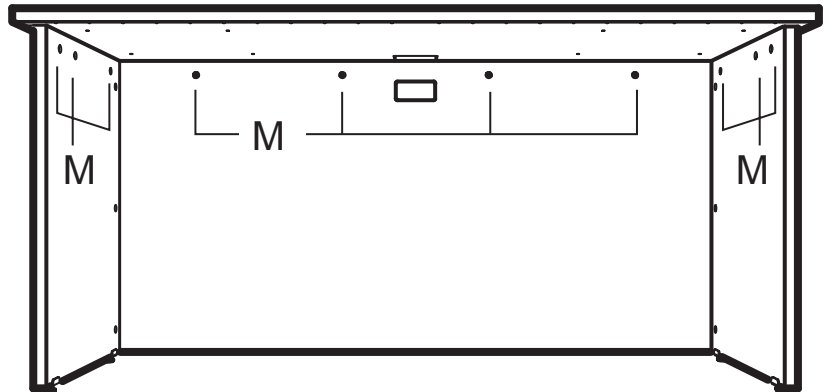

## #2

Turn the Minifix Cams (M) along the back edge of the selected Side Panel counterclockwise to loosen. Remove the Side Panel, then replace the Top.

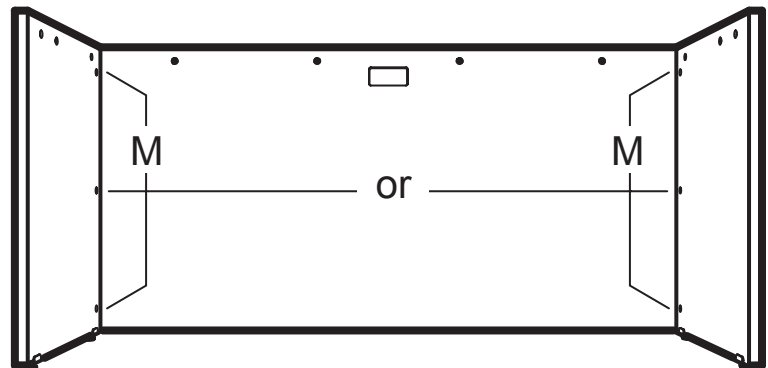

### #3

Unscrew the Minifix Bolts from the Top and Back. Remove the Wood Dowels from the Top.

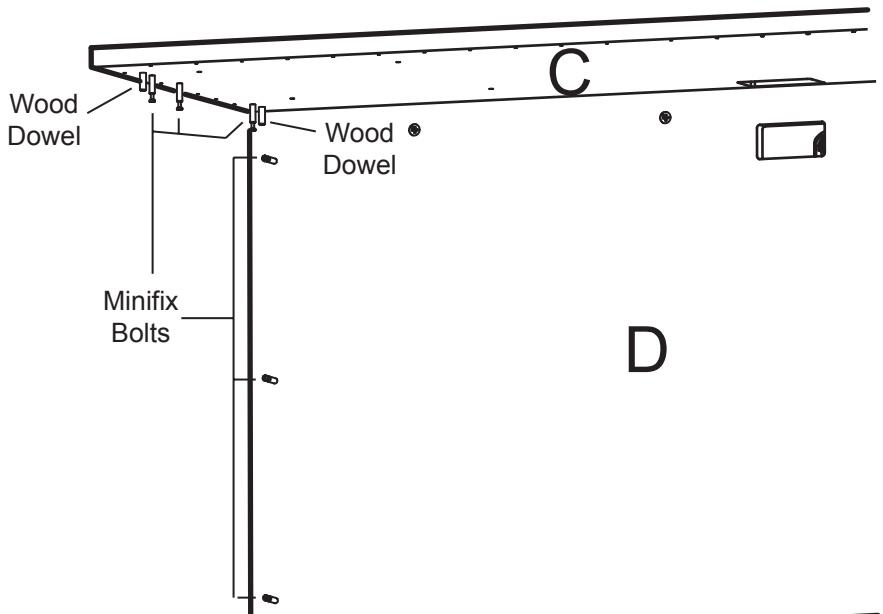

### #4

Attach the 18" Connector Plate (H1) to the underside of the Top Panel (C) of the attaching unit using eight of the **black #8 x 5/8" Panhead Screws (H2)** in the pre-drilled holes as shown.

**Do not use the color-matched Panhead Screws (H4) at this time.**

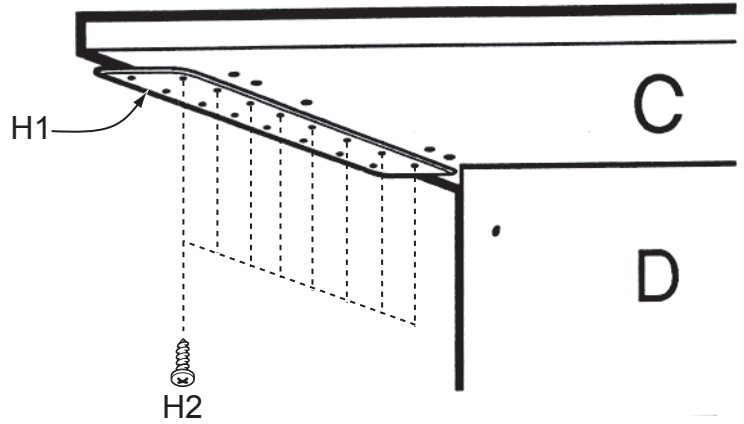

### #5

Position the attaching Desk Shell to the Desk Shell to be attached as shown. The back edge of the Top panel of the Desk Shell should be aligned with the side edge of the Top Panel of the other Desk Shell.

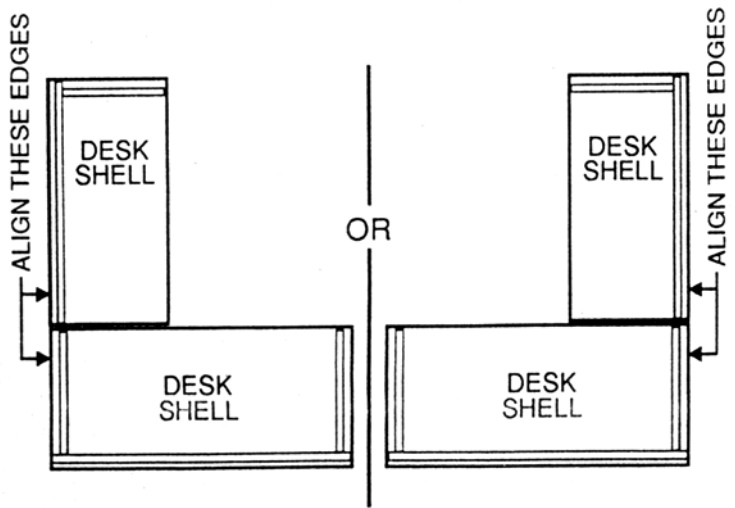

## #6

With the units aligned, secure the 18" Connector Plate (H1) to the underside of the Top Panel (C) of the attached unit using eight of the **black #8 x 5/8" Panhead Screws (H2)** in the pre-drilled holes as shown.

**Do not use the color-matched Panhead Screws (H4) at this time.**

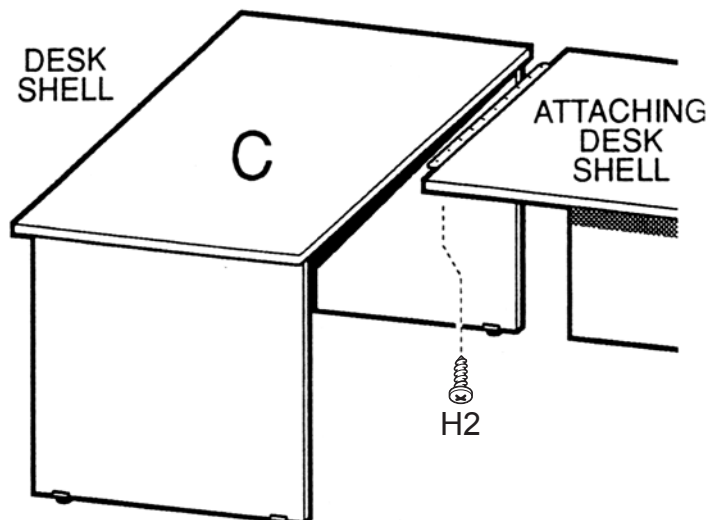

## #7

Position the Transition Bracket (H3) onto the units. The narrow flange of the Transition Bracket is positioned onto the attaching Desk Shell Back Panel as shown. With a pencil, mark the centers of the six holes of the Transition Bracket.

Drill pilot holes in the marked locations using a 1/8" drill bit in an electric drill.

**Note: Do not drill more than 1/2" deep into panels.**

Attach the Transition Bracket to the desk shells using six #8 x 5/8" Panhead Screws (H4) in the pilot holes as shown.

**Note: The color of the screws should match the color of the bracket.**

