



**IRONWOOD**  
MANUFACTURING

MOBILE 1000 SERIES

# 1041-CL

## Closed-General Storage w/Locks

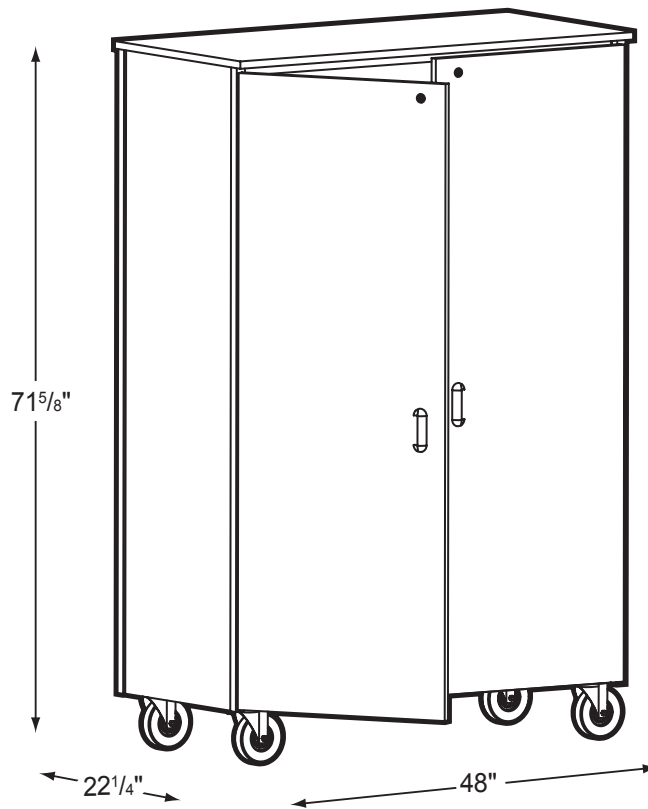

### Product Specs

- Fully welded unitized top and bottom frame
- 3/16" caster mounting plates
- 5" casters (2 locking)
- 5mm steel shelf supports
- 5 knuckle hinges w/hospital tips
- Triple bar magnetic catch
- Hooded abs plastic four fingered pull
- Five disk cam lock
- 3/4" thermal fused laminate
- 1" thermal fused laminate on shelves over 32"
- 3mm PVC edge banding on all semi and exposed edges
- Four adjustable shelves.
- One fixed shelf

0208