



IRONWOOD
MANUFACTURING

MOBILE 1000 SERIES

1019-0

Open - Low Storage Drawer with Shelf

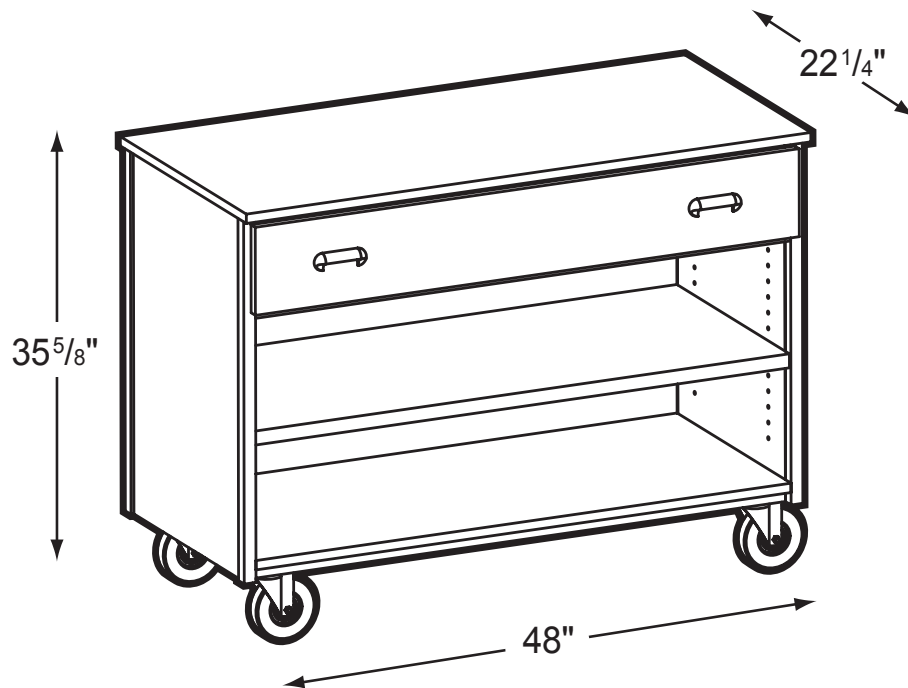

Product Specs

- Fully welded unitized frame
- 10 ga. angle iron
- 3/16" caster mounting plates
- 5" casters (2 locking)
- 5mm steel shelf supports
- 100# rated 2/3 extension drawer slide w/lock
- Hooded abs plastic four fingered pull
- 3/4" thermal fused laminate
- 1" thermal fused laminate on shelves over 32".
- 3mm PVC edge banding on all semi and exposed edges.
- One adjustable shelf.
- One full width drawer.

0309

Ironwood Manufacturing • P.O. Box 1420 • Missoula, Montana 59806
(406) 721-4747 • (800) 769-5693 • fax (406) 721-8424 • www.ironwoodmfg.com